



Civilittee

اللجنة الأكاديمية لقسم الهندسة المدنية

www.Civilittee.com

سلايدات

هندسة مياه عادمة

د. نداء الحلالشة

 www.civilittee.com

 CivilitteeHashemite

 Civilittee HU | لجنة المدني



Wastewater Treatment Engineering
CE 110401455

Water Quality Parameters

Instructor : Dr. Neda Halalsheh

Spring 26

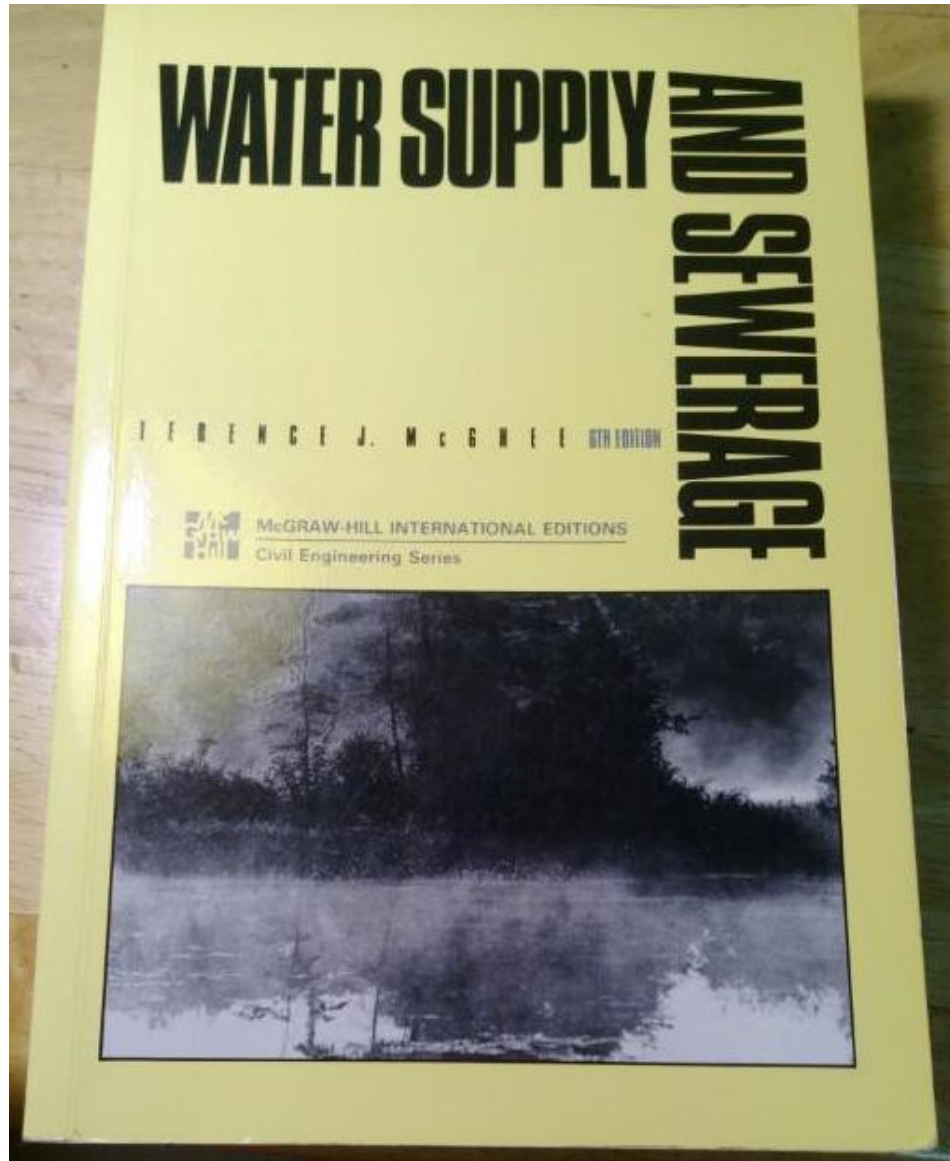

Textbook

- McGhee, T, (1991 or latest). **Water Supply and Sewerage**. 6th Edition, Mc-Graw-Hill Inc.

Course Description

- This course covers materials related to water quality parameters, sources of wastewater and flow quantities and quality, sewage collection system design, sewage purification works and disposal, primary treatment, secondary treatment, activated sludge system and waste stabilization ponds.

Major Topics Covered

Topic	No. of Weeks	Contact hours*
Water quality: physical, chemical and biological parameters.	1.5	7.5
Wastewater flow quantity: population growth, flow variations	1.5	7.5
Wastewater sewer system: analysis and design	1.5	7.5
Wastewater characteristics: solids, BOD, COD	1.5	7.5
Wastewater treatment: primary, secondary, activated sludge, WSP.	1.5	7.5
Exams	1/2	4
Total	8	41.5

Course Learning Outcomes

- Understand and solve civil engineering problems related to wastewater treatment technologies.
- Design of sewer systems and activated sludge plants.

Water Quality Parameters

Distribution of Earth's Water

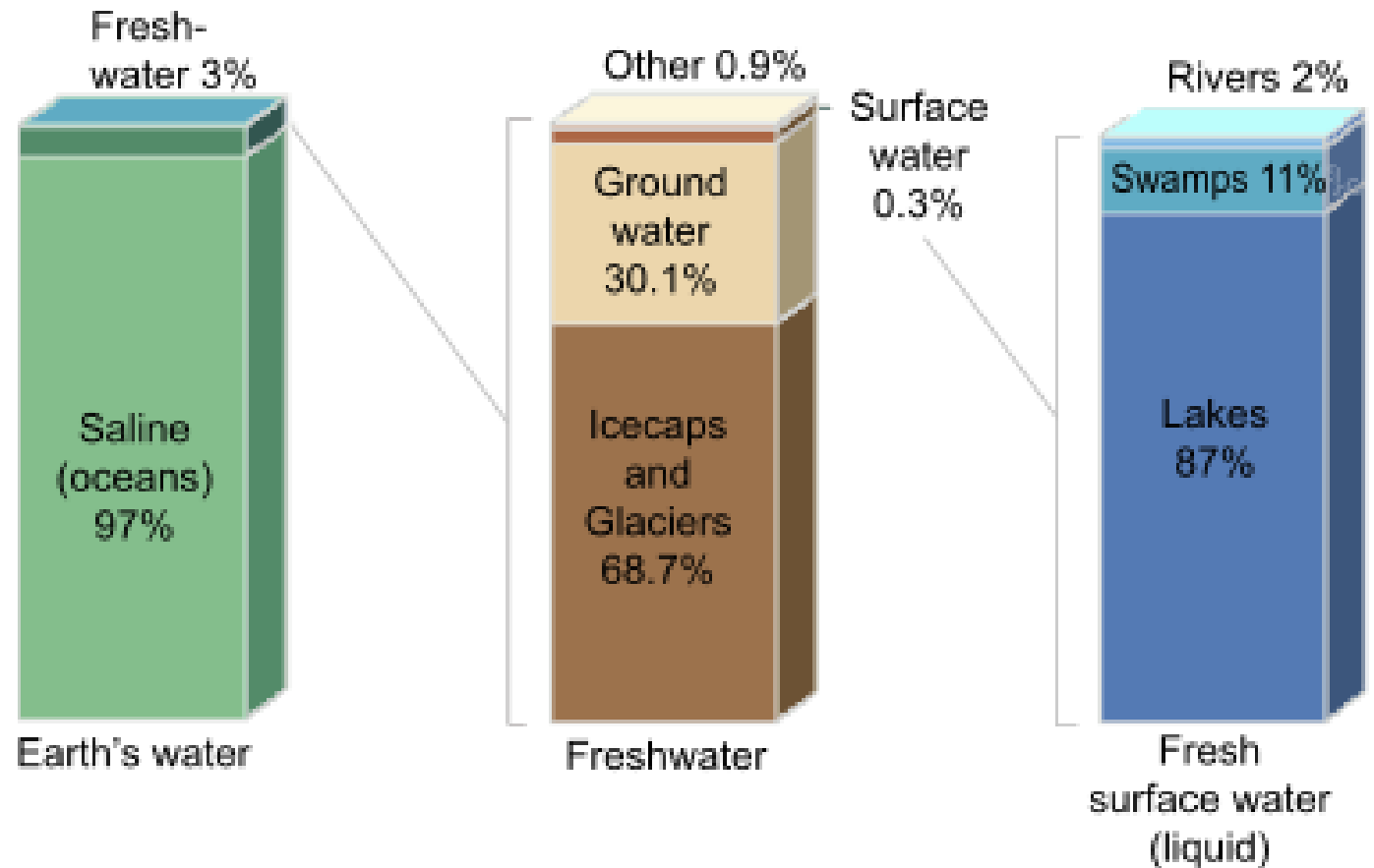

Water pollution

Water pollution occurs when **harmful substances** often chemicals or microorganisms—contaminate a stream, river, lake, ocean, aquifer, or other body of water, degrading **water quality** and rendering it toxic to humans or the environment.



Causes of water pollution



Water quality parameters

- Physical parameters.
- Chemical parameters.
- Biological parameters.



Physical parameters

- Characteristics that respond to the sense of sight, touch, taste or smell.
- Major Physical; parameters are:
 - Temperature.
 - Turbidity.
 - Taste.
 - Odor.
 - Color.
 - Suspended solids.

Temperature

- Surface waters fluctuate in temperature with season, while in groundwater there is only a small variation.
- Significance:
 - Warm water taste flat.
 - Influences rates of chemical and biological activities.
 - Influences the saturation values of dissolved gasses.
 - Heat pollution.



Water temperature affects nearly every other water quality parameter.

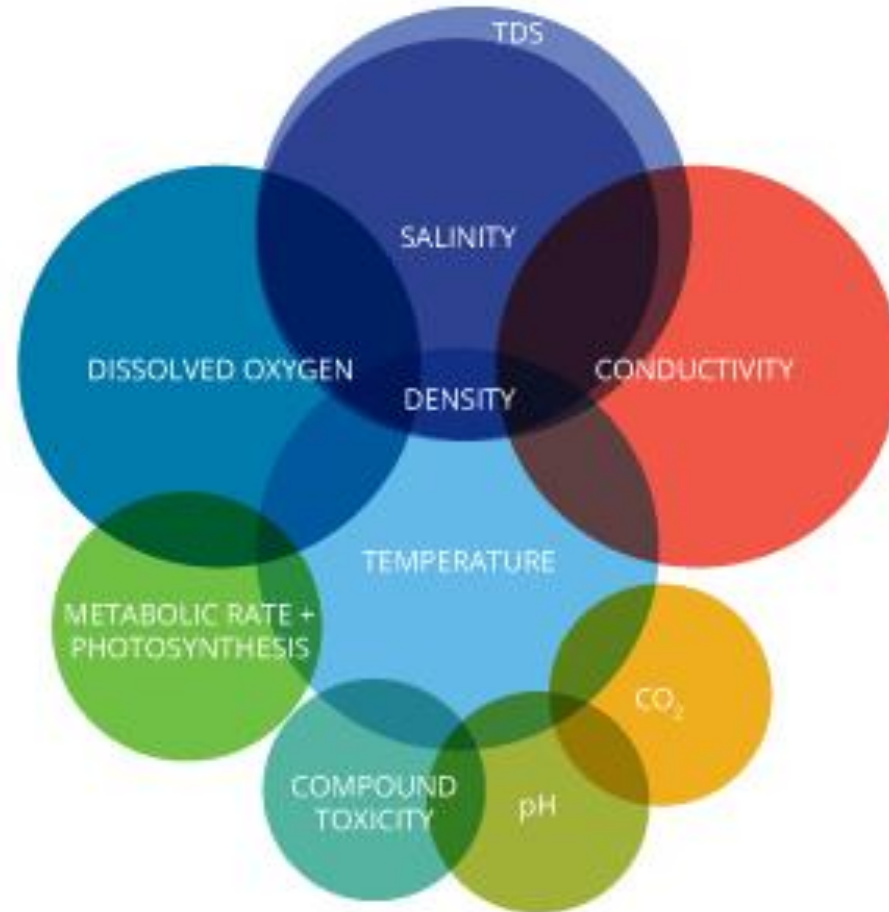

Turbidity

- Turbidity represents lack of clearness in water (measure of interference presented by suspended matter to passage of light).
- Lack of clearness is due to presence of clay, silt, microorganisms, ...



Total suspended solids (TSS) are particles that are larger than 2 microns found in the water column. Anything smaller than 2 microns (average filter size) is considered a dissolved solid

- Water in lake and ponds are less turbid, more turbid in rivers, and low turbid in wells.
- Significance
 - Aesthetic consideration.
 - Influence disinfection.
 - Affect filterability.

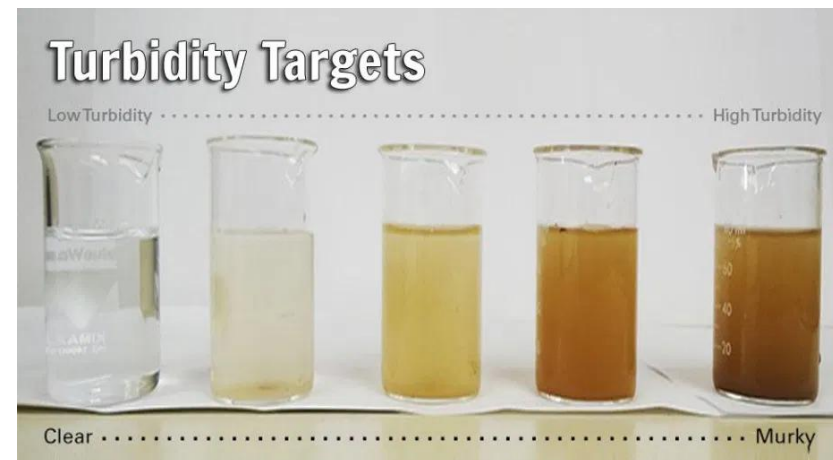

Taste and odors

- Odors are caused by volatile substances associated with:
 - Organic matter (decaying)
 - Living organisms (algae)
 - Gases (hydrogen sulfide, chlorine)
- Taste are caused by
 - Chlorides and sulfides of calcium, magnesium and sodium.
 - Organisms (algae)
 - Industrial waste



Chemical parameters

- Water parameters due to the presence of chemical Substances in water.
- Examples: total dissolved solids, alkalinity, hardness, metals, organic compounds and nutrients.



Total Solids

- Total Solids (**TS**): The total of all solids in a water sample.
- Total Suspended Solids (**TSS**): The amount of filterable solids in a water sample, filters are dried and weighed.
- Total Dissolved Solids (**TDS**): Non-filterable solids that pass through a filter with a pore size of 2 microns.

EPA secondary drinking water recommendation for TDS is less than 500 mg/L.

- Volatile Solids (**VS**): Those solids lost on heating to 550 °C – rough approximation of the amount of organic matter present in the solid fraction of wastewater.

Total Dissolved Solids (TDS)

- TDS represents mainly inorganic substances: bicarbonate, chlorides, and sulfate of Ca, Mg, And Na.
- Significance:
 - Taste.
 - Laxative effects.
 - Indication of hardness.
 - Waters with high TDS is not desirable for industries.

Total Suspended Solids (TSS)

Total suspended solids (TSS) are particles that are larger than 2 microns found in the water column. Anything smaller than 2 microns (average filter size) is considered a dissolved solid

Significance

High TSS can **block light** from reaching submerged vegetation. As the amount of light passing through the water is reduced, **photosynthesis slows down**. Reduced rates of photosynthesis **causes less dissolved oxygen** to be released into the water by plants. If light is completely blocked from bottom dwelling plants, the **plants** will stop producing oxygen and will **die**. As the **plants are decomposed**, **bacteria** will use up even **more oxygen** from the water. **Low dissolved oxygen** can lead to **fish kills**. **High TSS** can also cause an increase in **surface water temperature**, because the suspended particles **absorb heat from sunlight**. This can cause dissolved oxygen levels to fall even further (because warmer waters can hold less DO).

Analysis of total solids

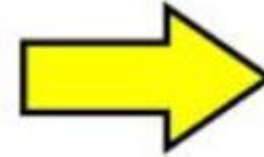
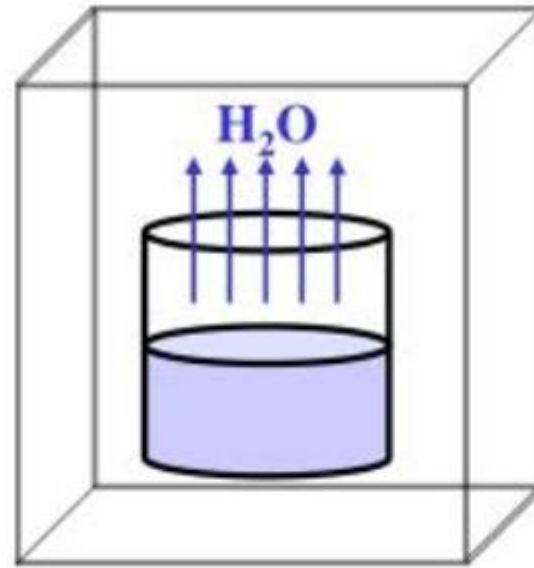
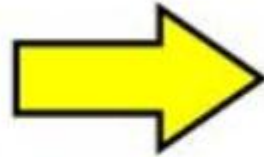
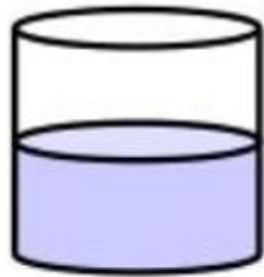

Pan of a known mass (M_{pan}) filled with a known volume of sample

Oven at 103 °C

Pan of a known mass with the mass of solids from the aqueous sample ($M_{\text{pan}} + M_{\text{solids}}$)

$$M_{\text{solids}} = (M_{\text{pan}} + M_{\text{solids}}) - (M_{\text{pan}})$$

Solids Analyses

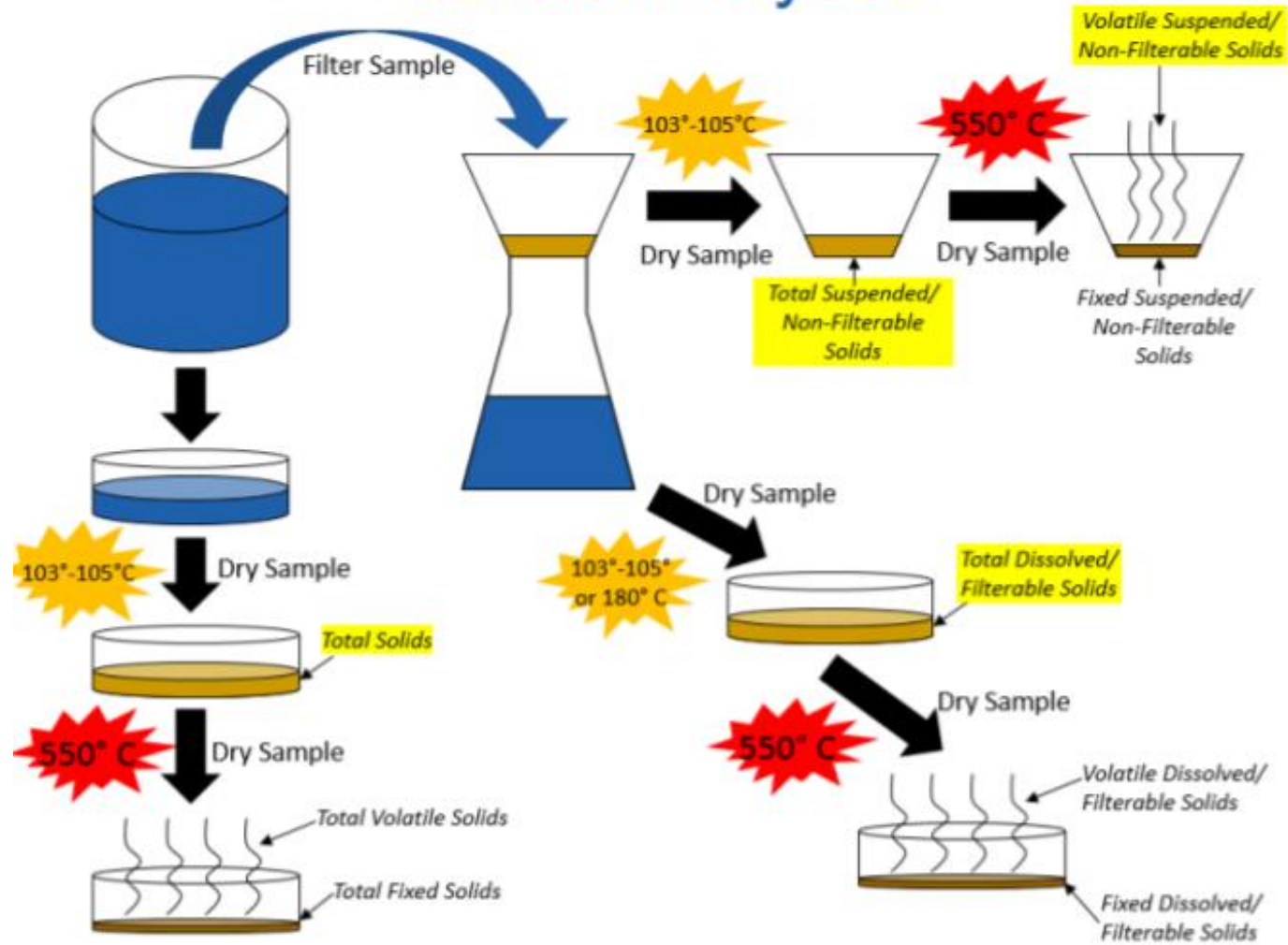

Example

- A filterable residue analysis is run on a sample of water as follows. Prior to filtering, the crucible and filter pad are kept overnight in the drying oven, cooled, and the dry mass (tare mass) of the pair determined to be 54.352 g. 250 mL of the sample is drawn through a filter pad contained in the porous-bottom crucible. The crucible and filter pad are then placed in a drying oven at 104°C and dried until a constant mass of 54.389 g is reached. Determine the suspended solids concentration of the sample.

pH

- Common logarithm of the reciprocal of hydrogen ion concentration.

- pH of most raw water sources : 6.5-8.5

- pH = 7, Neutral
- pH < 7, Acidic
- pH > 7, Alkaline

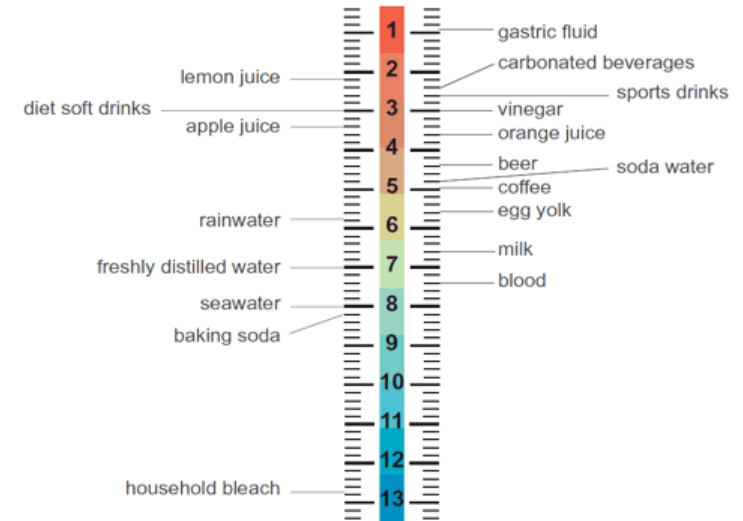
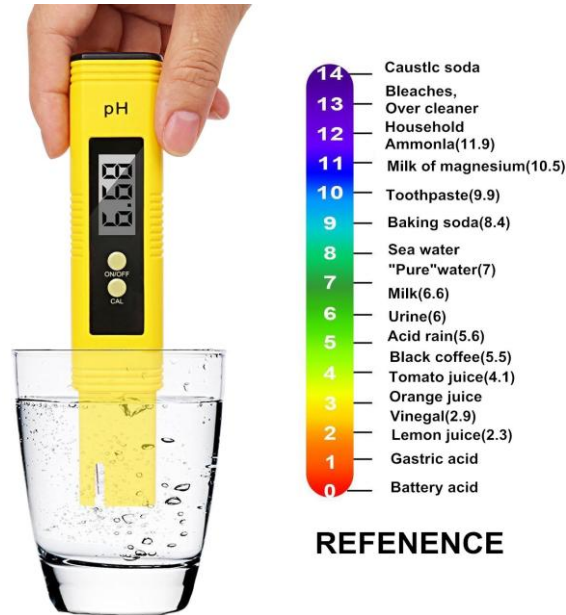

- Significance

- Influences chemical reactions (in coagulation, softening, disinfection, etc.)
- Corrosion problems (low pH)
- Optimum pH is required for fish and other aquatic life.

Examples

1- Calculate the pH of a 0.0025 M HCl solution.

Hint : HCl is a strong acid and is 100% ionized in water.

2- What is the pH of a solution that has a hydroxide ion concentration of 4.82×10^{-5} M?

Acidic or alkaline water!!!

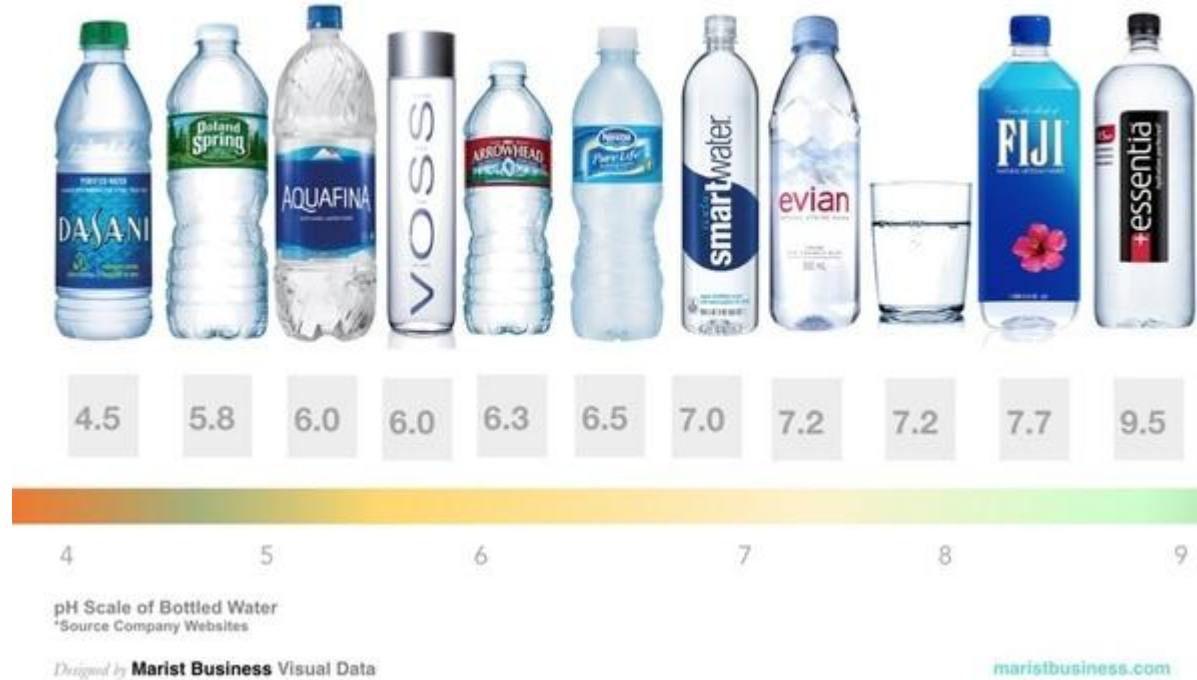

What about food?!

EAT LESS (-)		MORE ACIDIC		NEUTRAL	MORE ALKALINE		EAT MORE (+)
⊖⊖⊖⊖	⊖⊖⊖	⊖⊖	⊖		+	++	+++
Soft Drinks Energy Drink Carbonated Drinks	Popcorn Cream Cheese Buttermilk Pastries Pasta Cheese Pork Beef Beer, Wine Black Tea Pickles Roasted Nuts Vinegar Sweet & Low Equal, Nutra Sweet	Most Purified Water Distilled Water Coffee Chocolate Sweetened Fruit Juice Pistachios White Bread Peanuts Nuts	Fruit Juices Most Grains Eggs Fish Tea Soy Milk Coconut Lima Beans Plums Brown Rice Cocoa Oats Oysters Salmon	Most Tap Water Most Spring Water River Water	Apples Almonds Tomatoes Grapefruit Corn Mushrooms Turnip Olives Peaches Bell Pepper Radish Pineapple Cherries Wild Rice Apricot Strawberries Bananas	Avocados Green Tea Lettuce Celery Peas Sweet Potatoes Egg Plant Green Beans Beets Blueberries Pears Grapes Kiwi Melons Tangerines Figs Dates Mangoes Papayas	pHresh greens® Spinach Broccoli Artichoke Brussel Sprouts Cabbage Cauliflower Carrots Cucumbers Lemons Limes Seaweed Asparagus Kale Radish Collard Greens Onion
*Processed & Refined Food							*Raw / Uncooked

Note that a food's acid or alkaline-forming tendency in the body has nothing to do with the actual pH of the food itself. For example, lemons are very acidic, however the end-products they produce after digestion and assimilation are very alkaline so lemons are alkaline-forming in the body. Likewise, meat will test alkaline before digestion but it leaves very acidic residue in the body so, like nearly all animal products, meat is very acid-forming.

***Eat less processed and refined foods and more raw and uncooked greens and fruits.**

Alkalinity

- Alkalinity of water is a measure of its capability to neutralize acids, it is expressed in mg/ L as CaCO_3 (Why!)
- Alkalinity is mostly due to bicarbonates of Ca, Mg, and Na.
- Significance
 - Important in water treatment (Coagulation).
 - In industrial waters: deposits, corrosion, corrosion of steam lines.
 - Many industrial waters require rigid pH control.

- Alkalinity in water is due to the presence of:
 - Carbonates (CO_3^{-2})
 - Bicarbonates (HCO_3^-)
 - Hydroxide (OH^-)



- Alkalinity is determined by measuring the amount of acid needed to lower the pH in a water sample to a specific endpoints, the results are usually reported in standardized units as milligrams CaCO₃ per liter.
- To understand the processes that control the pH of natural waters, i.e., the balance between acids and bases. We shall focus our attention on the carbonate system.
- Carbon dioxide dissolves in water to form carbonic acid (H₂CO₃) which dissociates and is in equilibrium with bicarbonate and carbonate ions

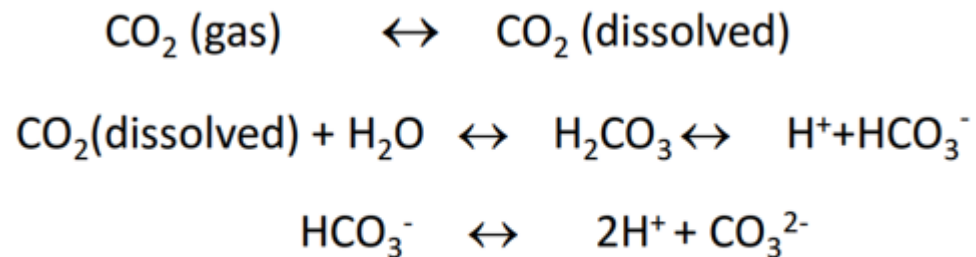

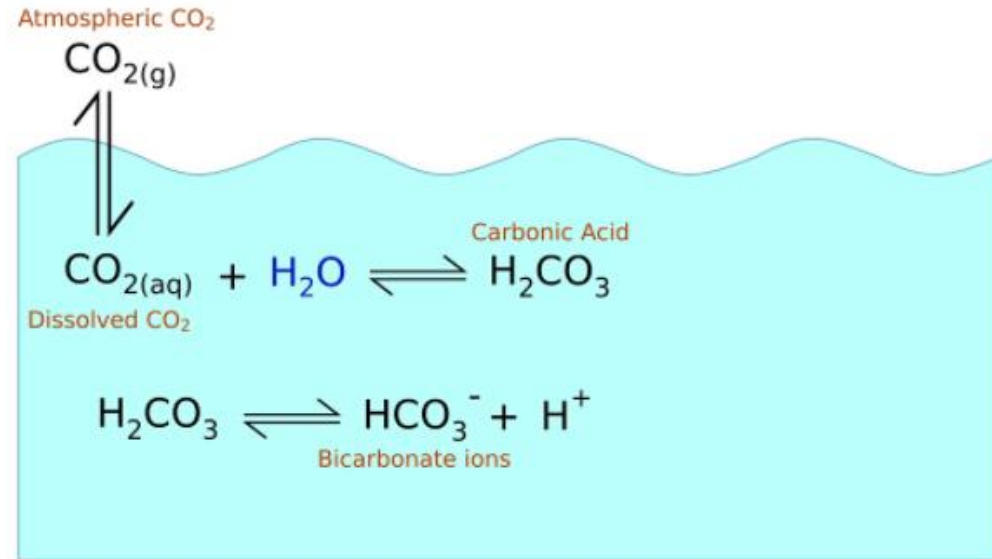
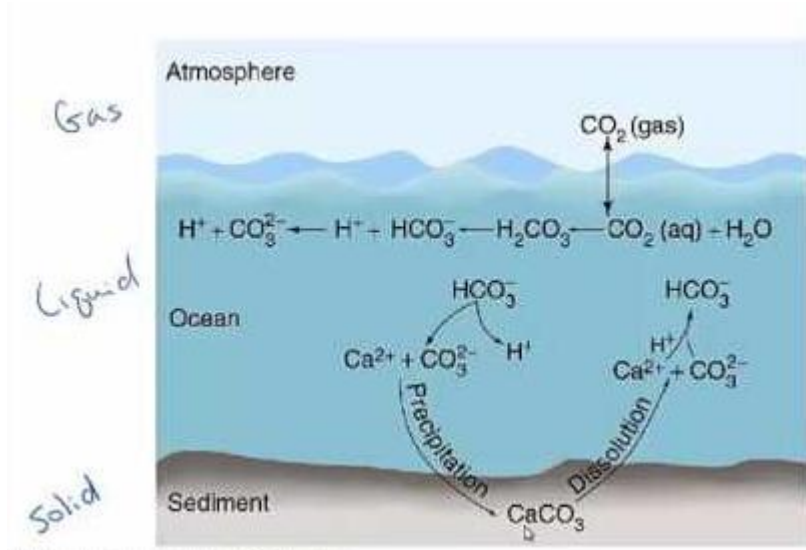

- Remember that Henry's Law determines the concentration of dissolved carbon dioxide in an aqueous solution exposed to the atmosphere.

Alkalinity analysis involves the titration of samples with standard 0.02N acid (usually H₂SO₄) titrant to endpoints of pH 8.3 and 4.5.

Phenolphthalein point (PA) – pH 8.3

Total alkalinity = Amount of acid used to reach pH 4.5 (ml) * Normality of acid (eq/L) * 50,000 (mg CaCO₃/eq) / sample volume (ml)

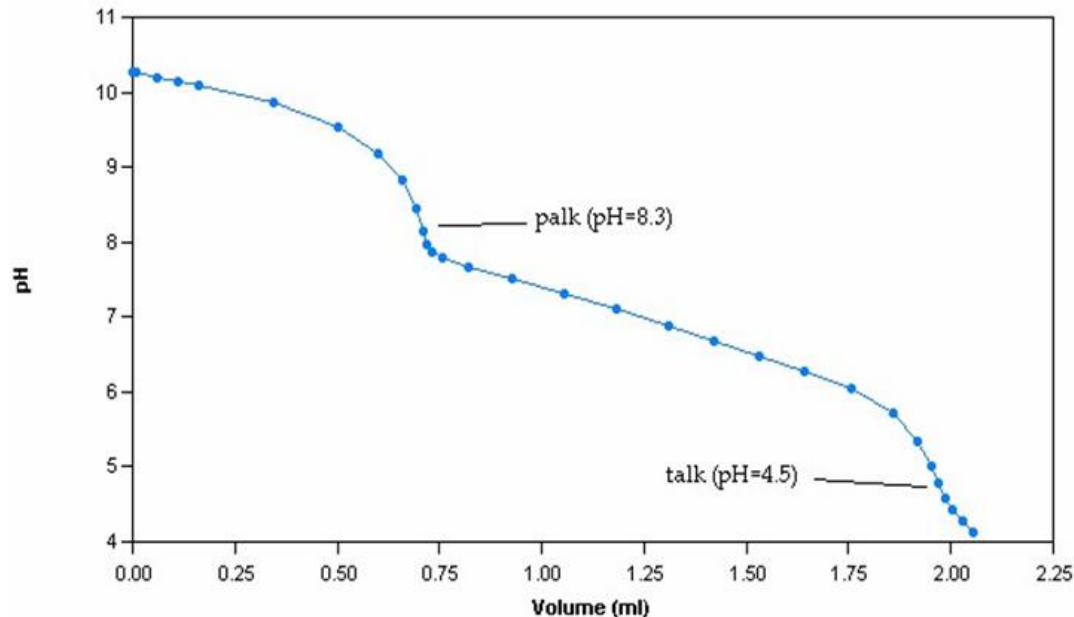

Phenolphthalein Alkalinity

= Amount of acid used to reach pH 8.3 (ml) * Normality of acid (eq/L) * 50,000 (mg CaCO₃/eq) / sample volume (ml)

Where Normality = Molarity (moles/L) * the number of hydrogen exchanged in a reaction (eq/moles)

Equivalent weight

The equivalent weight of an element or radical is equal to its **atomic weight** or **formula weight** divided by the **valence** it assumes in compounds.

Example

What is the equivalent weight of calcium carbonate (CaCO_3)

The molecular weight of the calcium carbonate can be calculated as follows

$$\begin{aligned} &= 1 \times 40 + 1 \times 12 + 3 \times 16 \\ &= 40 + 12 + 48 \\ &= 100 \end{aligned}$$

The molecular weight of the calcium carbonate is 100.

\therefore The equivalent weight of the calcium carbonate is $= 100/2 = 50$

$$\text{Phenolphthalein alkalinity (mg/L) as CaCO}_3 = \frac{A \times N \times 50,000}{\text{mL of sample}}$$

$$\text{Total alkalinity (mg/L) as CaCO}_3 = \frac{B \times N \times 50,000}{\text{mL of sample}}$$

Where:

A = titrant (mL) used to pH 8.3

B = titrant (mL) used to titrate to pH 4.5

N = normality of the acid (0.02 N H₂SO₄ for this alkalinity test)

50,000 = a conversion factor to change the normality into units of CaCO₃

Example

A 100 mL water sample is tested for phenolphthalein alkalinity. If 1.3 mL titrant is used to pH 8.3 and the sulfuric acid solution has a normality of 0.02 N, what is the phenolphthalein alkalinity of the water?

$$\text{Phenolphthalein alkalinity (mg/L as CaCO}_3) = \frac{A \times N \times 50,000}{\text{mL of sample}}$$

$$\text{Phenolphthalein alkalinity (mg/L as CaCO}_3) = \frac{1.3 \text{ mL} \times 0.02 \text{ N} \times 50,000}{100 \text{ mL}}$$

$$\text{Phenolphthalein alkalinity (mg/L as CaCO}_3) = 13 \text{ mg/L as CaCO}_3$$

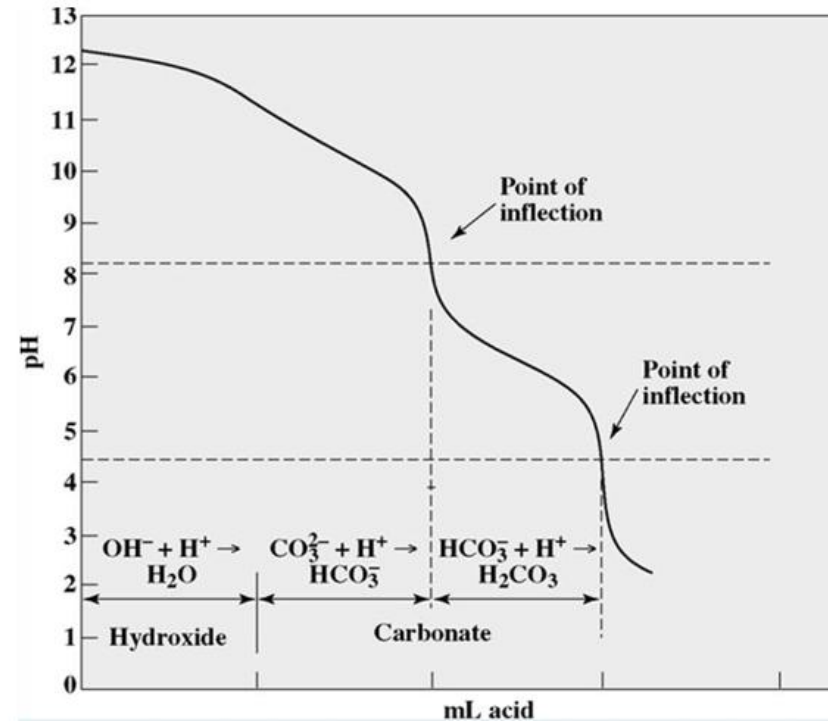

Example

- 2.0 mL of 0.01 M of Sulphuric acid was required to titrate 50 mL of a sample to pH 8.3. What is the phenolphthalein alkalinity?
 - Hint : Normality of H_2SO_4 !!

- 18.0 mL of 0.01 M of Sulphuric acid was required to titrate 50 mL of a sample to pH 4.5. What is the total alkalinity?

Alkalinity and pH

- Alkalinity is a measure of the buffering capacity of a solution, or the capacity of bases to neutralize acids.
- pH is a measure of the activity of hydrogen ions (H^+) in a solution.
- Most substances have a pH range between 0 and 14. Some extremely acidic and basic solutions can have a $pH < 0$ or $pH > 14$.

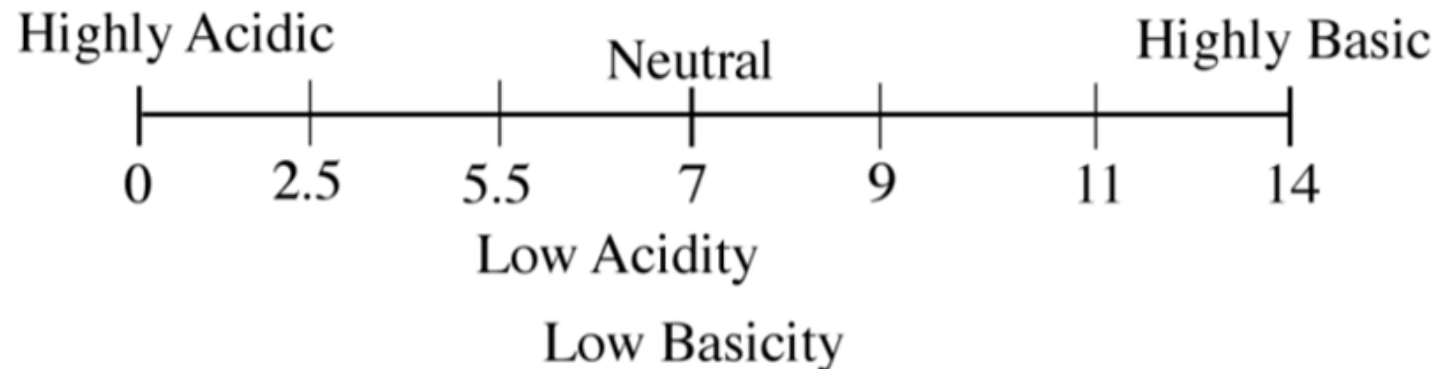

Example

- Calculate the alkalinity of a water sample, if 1 L contains 0.35 g of HCO_3^- and 0.12 g of CO_3^{2-} carbonate ions.

Hardness

- Water hardness is the traditional measure of the capacity of water to react with soap, hard water requiring considerably more soap to produce a lather!

why soap!

Soaps are denoted by the general formula RCOO^-Na^+ , where R is any long chain alkyl group consisting 12 to 18 carbon atoms. Some common examples of fatty acids that are used in soaps are **stearic acid** having chemical formula $\text{C}_{17}\text{H}_{35}\text{COOH}$, **palmitic acid** having chemical formula $\text{C}_{15}\text{H}_{31}\text{COOH}$

- Hardness in water is due to the presence of divalent metal cations **mainly** calcium (Ca) and magnesium (Mg).
- Types of hardness of water:

- Temporary hardness

Due to the presence of bicarbonate of Ca, and Mg, i.e. $\text{Ca}(\text{HCO}_3)_2$. It is called temporary since it can be easily removed by boiling and filtering the water. Temporary hardness is also called **carbonate hardness**.

- Permanent hardness

Due to the presence of soluble chlorides and sulphates of calcium and magnesium, i.e. CaCl_2 , CaSO_4 , MgCl_2 , MgSO_4 . This type of hardness is called permanent hardness since it cannot be removed simply by boiling the water. Permanent hardness is also called **Non-carbonate hardness**.



Water hardness rating

mg/L as CaCO ₃	Degree of Hardness
0-75	Soft water
75-150	Moderately hard water
150-300	Hard water
>300	Very hard water

*Hardness is normally expressed in terms of CaCO₃ as is alkalinity

- Significance:
 - Scale build-up in a boilers and hot water systems.
 - Excessive soap usage.
 - Fuel wastage.
 - Poor cleaning of clothes and reduced fabric life.

$$\text{Hardness (mg/L) as CaCO}_3 = M^{2+} \text{ (mg/L)} \times \frac{50}{\text{EW of } M^{2+}}$$

where M^{2+} represents any divalent metallic ion and EW represents equivalent weight

Example

Water has the following analysis. Calculate values of total hardness

Ion type	Concentration (mg/L)	Ion type	Concentration (mg/L)
Na ⁺	20	Cl ⁻	40
Ca ²⁺	5	CO ₃ ²⁻	10
Mg ²⁺	10	SO ₄ ²⁻	5

Only cations with bivalency contribute to hardness

Cation	Concentration (mg/L)	Equivalent weight (g/mole)	Hardness (in mg/L) as CaCO ₃
Ca ²⁺	5	20	$= (5) * [(50)/(20)] = 12.5$
Mg ²⁺	10	12.2	$= (10) * [(50)/(12.2)] = 41$

Total hardness = 12.5+41=53.5 mg/L as CaCO₃

Dissolved Oxygen (DO)

Dissolved oxygen (DO) is a measure of how much oxygen is dissolved in the water - the amount of oxygen available to living aquatic organisms. The amount of dissolved oxygen in a stream or lake can tell us a lot about its water quality.

Oxygen-content of water

- Biological decomposition of organic matter uses up the dissolved oxygen. Hence, DO is the most important single criterion indicating the sanitary of water.
- Water deficit in DO is likely to be polluted with organic matter. Why!

Significance

- Measure of the impact of oxidizable wastes in water.
- Lack of DO affects fish and aquatic life.
- For determining biochemical oxygen demands of wastewater.

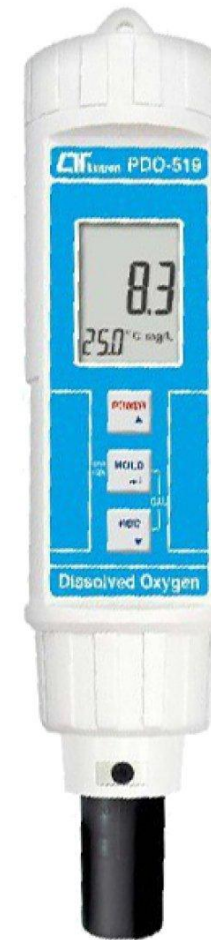

DO Meter



BOD bottle

Field and lab meters to measure dissolved oxygen are used. modern meters are small and highly electronic.

Biological Oxygen Demand (BOD)



BOD bottle



- Biological Oxygen Demand (**BOD**) is a measure of the DO required for the utilization of organic matter as food by the aerobic microorganisms.
- BOD is measured by DO determination before and after an incubation period of 5 days at 20°C.
- BOD is indirect measure of the amount of readily biodegradable organic matter.
- It is a measure of the strength of wastewater.

Significance

- Pollution strength of domestic and industrial wastewater.
- Evaluation of self-purification capacity of receiving water.
- Assessing efficiency of wastewater treatment process.

Chlorides

- Chlorides are present in all water sources.
- Chlorides get into water from:
 - Mineral deposits
 - Domestic wastewater discharge
 - Irrigation drainage
 - Human excreta (urine) contains chloride, about 6 g/capita.day.
- **Significance**
 - Undesirable taste.
 - Contributes to hardness
 - In industrial waters : deposits, boiler corrosion.



Fluorides

- Fluorides are present in water from:
 - Fluoride- containing minerals in the ground.
 - Industries (fertilizers, bricks, ceramics, pharmaceutical products).

Significance

- Less than 1 mg/ L : dental caries.
- More than 1.5 mg/ L mottling of enamel of teeth.
- 3 to 6 mg/ L skeletal fluorosis.
- More than 10 mg/ L : crippling skeletal fluorosis.
- Influences of temperature!



Sulfates

- Sulfates are present in water from:
 - Solvent action of water on gypsum and other salts.
 - Decomposition of organic matter.
 - Atmospheric SO_2 (acid rain)

Significance

- Laxative effects.
- Tastes.
- Scales in boilers.
- Hardness.



Biological parameters - Coliforms

Biological water characteristics are used to describe the presence of **microbiological organisms** and **water- borne pathogens**.

Microorganisms and waterborne pathogens generally enter rivers and lakes when they are contaminated by human faeces, for example when sanitation is lacking, or untreated or partially treated sewage is discharged into it.

Testing for pathogens is very difficult

- A wide variety of pathogens.
- Tests for pathogens present is small.

Indicator organisms

- Organisms normally present in the feces of human are used as indicator organisms. If present in water, they indicate the presence of fecal material and hence the presence of intestinal pathogens.

Coliforms as indicator organisms

- The number of coliforms in feces is very large.
- Rates of removal/decay/death of coliforms are parallel to that of pathogens.
- Tests are simple.

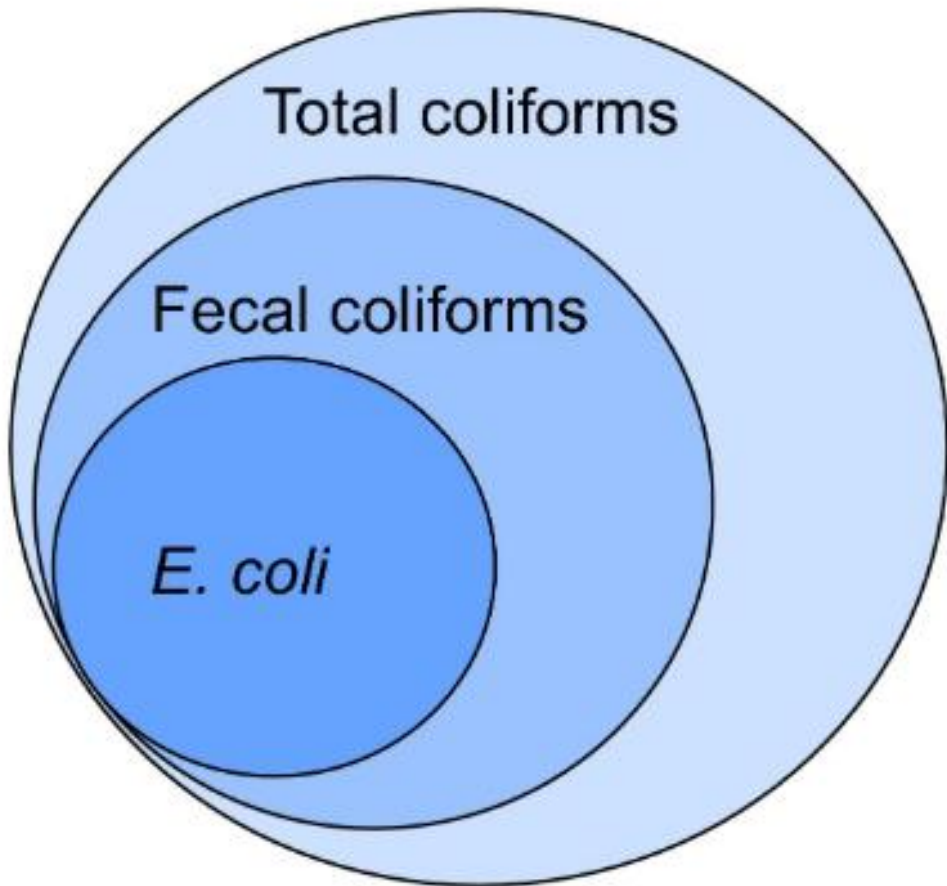

Total coliforms are present throughout the environment. They are found in soil, water, and human or animal waste.

Fecal coliforms are a group of bacteria within the total coliforms and are present in the gut and waste of warm-blooded animals.

E. coli is a specific species of fecal coliform bacteria. It is the best indicator of fecal pollution. Only rare strains of *E. coli* can cause serious illness

Bacteria
Monera
Proteobacteria
Gammaproteobacteria
Enterobacteriales
Enterobacteriaceae
Escherichia
coli

Domain
 Kingdom
 Phylum
 Class
 Order
 Family
 Genus
 Species

Drinking water standards

A **maximum contaminant level (MCL)** is the highest level of a contaminant that is allowed in drinking water. MCLs are set as close to the **maximum contaminant level goals (MCLG)** as feasible using the best available treatment technology. **MCLG** is the level of contaminant in drinking water below which there is no known or expected risk to health.

Water standards

- Defined as water quality parameters established for public water supplies by regulatory authorities to define the limiting concentrations of various constituents.
- Limiting concentrations are those that can be tolerated for the intended use.
- Revised periodically.

Drinking water standards

- Many developed countries specify standards to be applied in their own country.
- Standards include:
 - Environmental Protection Agency (EPA) – USA.
 - Safe Drinking Water Act (SDWA) which is implemented by EPA.
 - World Health Organization (WHO).
 - European Union (EU).

- Drinking [water quality](#) in Jordan is governed by Jordanian Standard 286 of 2015, which is based on the [World Health Organization](#) drinking water guidelines.

Chemical Standards
(Compounds affecting health and water suitability)

Element/Compound	Symbol	Acceptable Level (mg/l)	MCL (mg/l)
Total Dissolved Solids	TDS	500	1500
Total Hardness	TH (CaCO ₃)	100	500
Detergents	ABS	0.5	1
Aluminum	Al	0.2	0.3
Iron	Fe	0.3	1
Manganese	Mn	0.1	0.2
Copper	Cu	1	1.5
Zinc	Zn	5	15
Sodium	Na	200	400
Nickel	Ni	0.05	0.1
Chloride	Cl	200	400
Fluoride	F	1	1.5
Sulfate	SO ₄	200	500
Nitrate	NO ₃	45	70
Silver	Ag	0.01	0.05
Magnesium	Mg	50	120
Calcium	Ca	100	200
Potassium	K	10	12

Jordanian standards?

**Chemical Standards
(Toxic elements)**

Jordanian standards?

Parameter	Symbol	MCL (mg/l)
Lead	Pb	0.01
Selenium	Se	0.01
Arsenic	As	0.05
Chromium	Cr	0.05
Cyanide	Cn	0.05
Cadmium	Cd	0.005
Mercury	Hg	0.001
Antimony	Sb	0.005
Nickel	Ni	0.05



Environmental photographer of the
year 2022 winners

'The Bitter Death of Birds'





Environmental photographer of the year 2019 winners

Water, equality and sustainability
Water Scarcity _Kakamega, Kenya



Underwater cleaning in the Bosphorus as part of the Zero Waste Blue project - Turkey



A women sleeps on a dirty riverbank _ Dhaka, Bangladesh



A boy plays with a plastic bag _ Burkina Faso



landfill_Nepal





Wastewater Treatment Engineering

CE 11401455

Wastewater flow quantity

Water availability and population growth

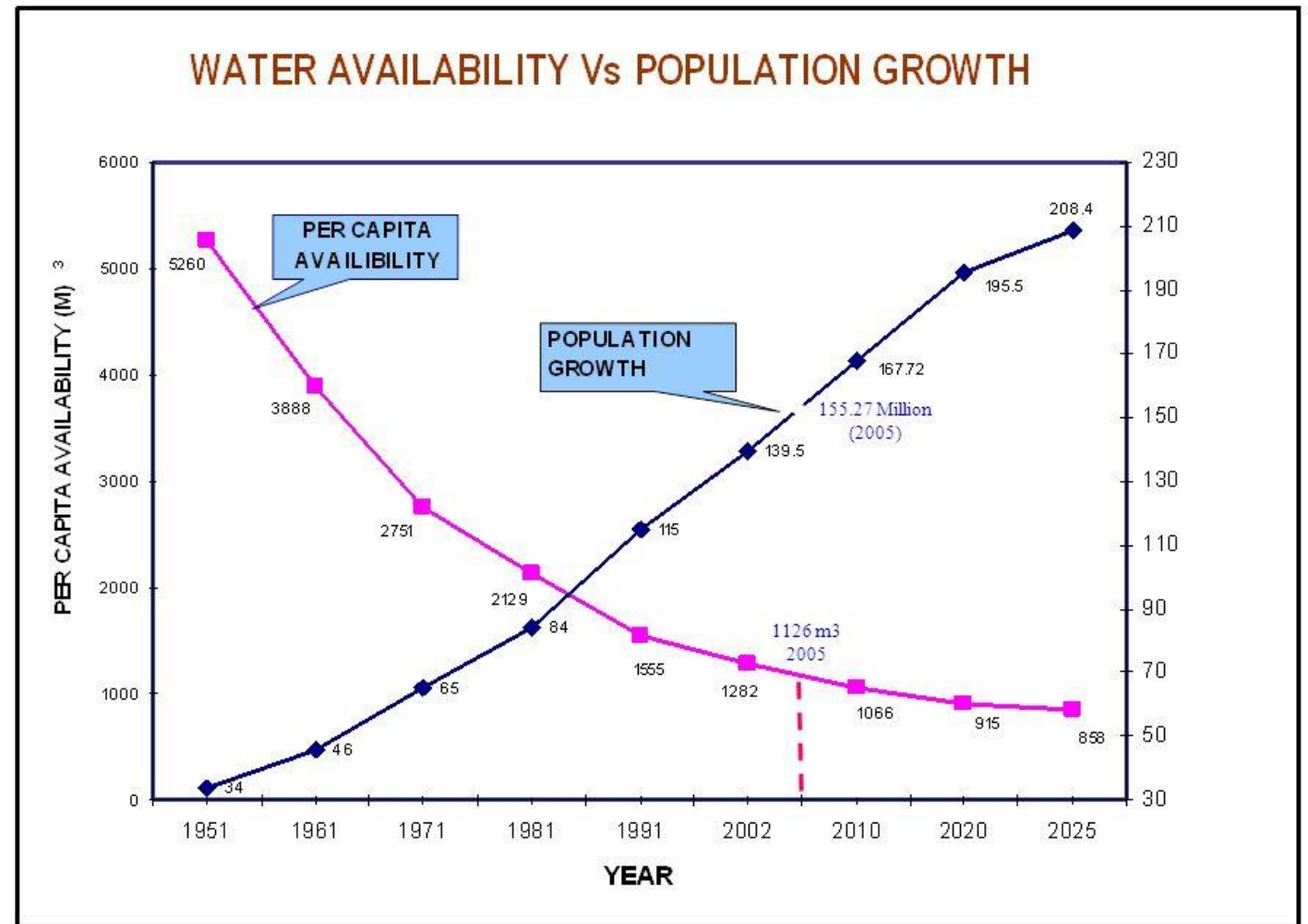

Global water crisis: Facts and Statistics

785 million people don't have clean water close to home.

2 billion people don't have a decent toilet of their own.

31% of schools don't have clean water

Every minute a newborn dies from infection caused by lack of safe water and an unclean environment.

Diarrhea caused by dirty water and poor toilets kills a child under 5 every 2 minutes.



WATER - THE FACTS

700 MILLION

people could be displaced by extreme water scarcity by 2030

(Global Water Institute 2013)



More than **FIVE BILLION** people could live in water-stressed regions by 2050

(Burek et al. 2016)



85%

of wetlands are estimated to have been lost since the pre-industrial era and the rate of loss is still accelerating

(IPBES 2019)

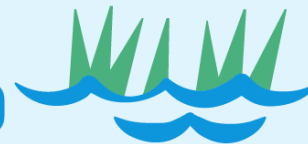

72% of all water withdrawals are used by agriculture, 16% by municipalities for households and services, and 12% by industries

(UN-Water 2021)

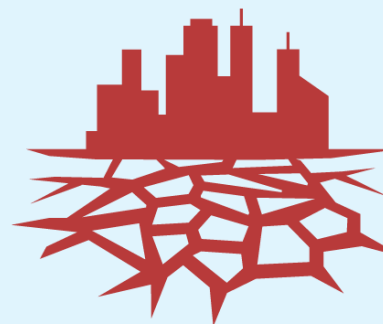

HALF of the world's largest cities already experience water scarcity

(World Economic Forum 2017)

Importance of water treatment

- Protect public health.
- Protect surface water quality.
- Meet legal requirements.

Specific concern : pathogenic organisms!!! (Wastewater)!

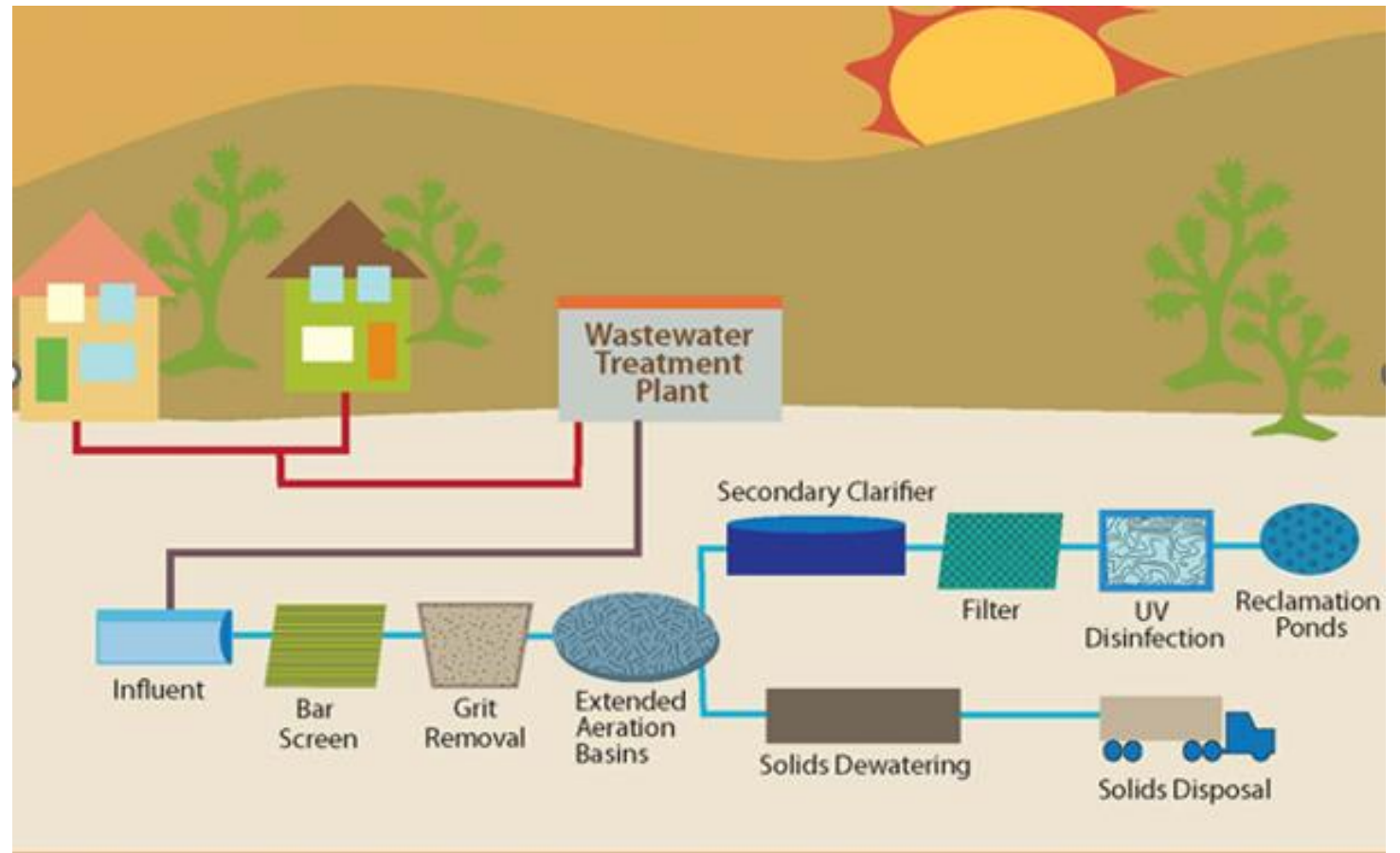

Why do we need to measure wastewater flow?

- Determining the rates of wastewater flow is a fundamental step in the design of the wastewater collection, treatment, and disposal facilities.
- In situation where wastewater flow rate data are limited or unavailable, wastewater flow rate estimates have to be developed from water consumption records and other information.
- Estimated residential flow rates need to be account for not only averages, but peak flows. Peak flows of short duration may or may not have a deleterious affect, however peak flows that continue for days can include hydraulic failure.





Population forecasting

Source (<https://scetcivil.weebly.com/>)

Four basic components of population change:

- *Births*
- *Deaths*
- *Inmigration*
- *Outmigration*

Excess of births over deaths results in natural increase.

Excess of deaths over births results in natural decrease.

The difference between inmigration and outmigration is net migration.

Cont.

- The present and past population record for the city can be obtained from the census population records. After collecting these population figures, the population at the end of design period is predicted using various methods as suitable for that city considering the growth pattern followed by the city.

Cont. Population forecasting

- Following are the commonly used methods for forecasting:
- 1) Arithmetic increase method .
- 2) Geometric increase method.
- 3) Incremental increase method.
- 4) Simple graphical method.
- 5) The logistic curve method.

Arithmetical Increase Method

This method is suitable for large and old city with considerable development. If it is used for small, average or comparatively new cities, it will give low result than actual value. In this method the average increase in population per decade is calculated from the past census reports. This increase is added to the present population to find out the population of the next decade.

it is assumed that the population is increasing at constant rate. Hence, $dP/dt = C$ i.e. rate of change of population with respect to time is constant. Therefore, Population after n^{th} decade will be $P_n = P + n.C$ Where,

P_n is the population after n decade and P is present population.

Example:1

Predict the population for the year 2021, 2031, and 2041 from the following population data.

Year	1961	1971	1981	1991	2001	2011
Population	8,58,545	10,15,672	12,01,553	16,91,538,	20,77,820,	25,85,862

Solution

Year	Population	Increment
1961	858545	-
1971	1015672	157127
1981	1201553	185881
1991	1691538	489985
2001	2077820	386282
2011	2585862	508042

Average increment = 345463

Population in year 2021 is, $P_{2021} = 2585862 + 345463 \times 1 = 2931325$

Similarly,

$$P_{2031} = 2585862 + 345463 \times 2 = 3276788$$

$$P_{2041} = 2585862 + 345463 \times 3 = 3622251$$

Problem (1)

- With the help of the following data find the population for the year 2040 using the arithmetic increase method

Year	Population
1950	34800
1960	52200
1970	82400
1980	11040
1990	12200
2000	16900
2010	18900
2020	22000

Geometrical Increase Method

- In this method the percentage increase in population from decade to decade is assumed to remain constant. Geometric mean increase is used to find out the future increment in population. Since this method gives higher values and hence should be applied for a new industrial town at the beginning of development for only few decades.
- The population at the end of nth decade 'P_n' can be estimated as:
- $P_n = P (1 + IG/100)^n$ Where
IG = geometric mean (%)
P = Present population

Example : 2

Considering data given in example 1 predict the population for the year 2021, 2031, and 2041 using geometrical progression method.

Solution

Year	Population	Increment	Geometrical increase Rate of growth
1961	858545	-	
1971	1015672	157127	$(157127/858545)$ $= 0.18$
1981	1201553	185881	$(185881/1015672)$ $= 0.18$
1991	1691538	489985	$(489985/1201553)$ $= 0.40$
2001	2077820	386282	$(386282/1691538)$ $= 0.23$
2011	2585862	508042	$(508042/2077820)$ $= 0.24$

$$\text{Geometric mean } I_G = (0.18 \times 0.18 \times 0.40 \times 0.23 \times 0.24)^{1/4}$$
$$= 0.235 \text{ i.e., } 23.5\%$$

$$\text{Population in year 2021 is, } P_{2021} = 2585862 \times (1 + 0.235)^1 = 3193540$$

Similarly for year 2031 and 2041 can be calculated by,

$$P_{2031} = 2585862 \times (1 + 0.235)^2 = 3944021$$

$$P_{2041} = 2585862 \times (1 + 0.235)^3 = 4870866$$

Problem (2)

- With the help of the following data find the population for the year 2040 using the Geometrical Increase Method

Year	Population
1950	34800
1960	52200
1970	82400
1980	11040
1990	12200
2000	16900
2010	18900
2020	22000

Incremental Increase Method

- This method is modification of arithmetical increase method, and it is suitable for an average size town under normal condition where the growth rate is found to be in increasing order.
- Hence, population after nth decade is $P_n = P + n.X + \{n(n+1)/2\}.Y$ Where, P_n = Population after nth decade X = Average increase Y = Incremental increase

Example : 3

Considering data given in example 1 predict the population for the year 2021, 2031, and 2041 using incremental increase method.

Year	Population	Increase (X)	Incremental increase (Y)
1961	858545	-	-
1971	1015672	157127	-
1981	1201553	185881	+28754
1991	1691538	489985	+304104
2001	2077820	386282	-103703
2011	2585862	508042	+121760
	Total	1727317	350915
	Average	345463	87729

$$\text{Population in year 2021 is, } P_{2021} = 2585862 + (345463 \times 1) + \{(1(1+1))/2\} \times 87729 \\ = 3019054$$

$$\text{For year 2031 } P_{2031} = 2585862 + (345463 \times 2) + \{(2(2+1)/2)\} \times 87729 \\ = 3539975$$

$$P_{2041} = 2585862 + (345463 \times 3) + \{(3(3+1)/2)\} \times 87729 \\ = 4148625$$

Problem (3)

- With the help of the following data find the population for the year 2040 using the Incremental Increase Method

Year	Population
1950	34800
1960	52200
1970	82400
1980	11040
1990	12200
2000	16900
2010	18900
2020	22000

Simple graphical method

- In this method, the populations of last few decades are correctly plotted to a suitable scale on graph. The population curve is smoothly extended for getting future population. This extension should be done carefully, and it requires proper experience and judgment. The best way of applying this method is to extend the curve by comparing with population curve of some other similar cities having the similar growth condition.

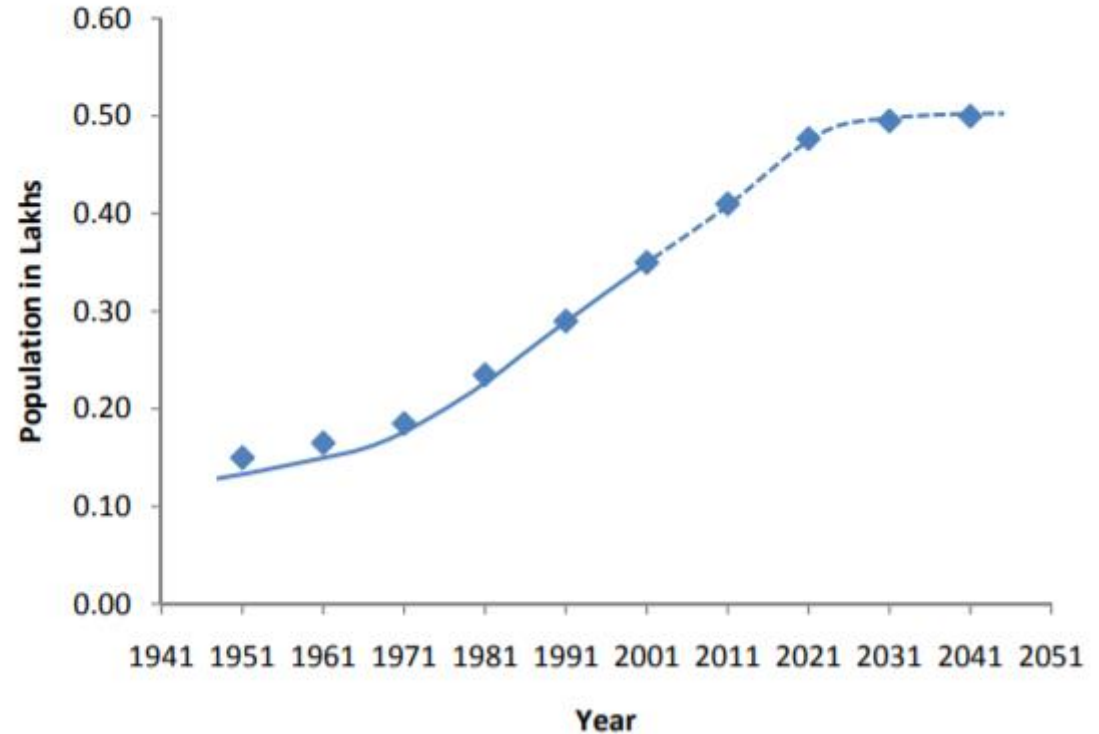

Problem (4)

- With the help of the following data find the population for the year 2040 using the Simple graphical method

Year	Population
1950	34800
1960	52200
1970	82400
1980	11040
1990	12200
2000	16900
2010	18900
2020	22000

Logistic curve method

- This method is used when the growth rate of population due to births, deaths and migrations takes place under normal situation and it is not subjected to any extraordinary changes like epidemic, war, earthquake or any natural disaster etc. the population follow the growth curve characteristics of living things within limited space and economic opportunity. If the population of a city is plotted with respect to time, the curve so obtained under normal condition is look like S-shaped curve and is known as logistic curve.

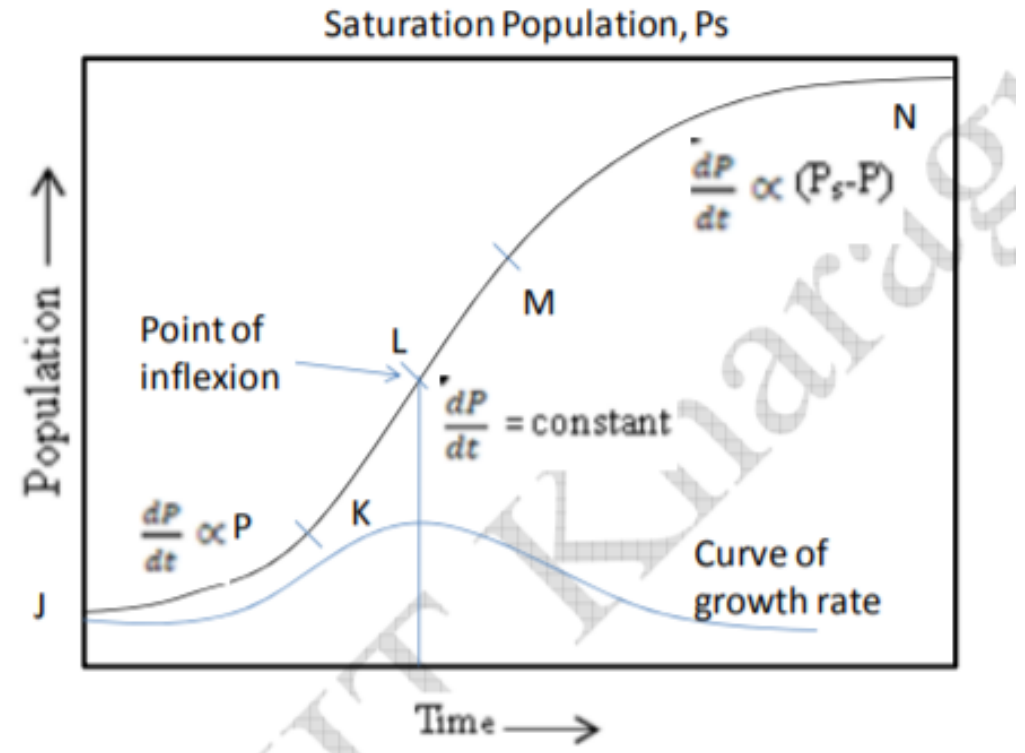

Verhulst has put forward a mathematical solution for this logistic curve JN which can be represented by an autocatalytic first order equation, given by

$$\log_e \left(\frac{P_S - P}{P} \right) - \log_e \left(\frac{P_S - P_0}{P_0} \right) = -K.P_s.t$$

P = Population at any time t from the origin J

P_s = Saturation population

P₀ = Population of the city at the start point J

K = Constant

t = Years

From the above equation we get

$$\log_e \left(\frac{P_S - P}{P} \right) \left(\frac{P_0}{P_S - P_0} \right) = -K.P_s.t$$

After solving we get,

$$P = \frac{P_s}{1 + \frac{P_s - P_0}{P_0} \log_e^{-1}(-K.P_s.t)}$$

Substituting $\frac{P_s - P_0}{P_0} = m$ (a constant)

and $-K.P_s = n$ (another constant)

we get $P = \frac{P_s}{1 + m \log_e^{-1}(n.t)}$

This is the required equation of the logistic curve, which will be used for predicting population. McLean further suggested that if only three pairs of characteristic values P_0, P_1, P_2 at times $t = t_0 = 0, t_1$ and $t_2 = 2t_1$ extending over the past record are chosen, the saturation population P_s and constant m and n can be estimated by the following equation, as follows:

$$P_s = \frac{2P_0P_1P_2 - P_1^2(P_0 + P_2)}{P_0P_2 - P_1^2}$$

$$m = \frac{P_s - P_0}{P_0}$$

$$n = \frac{2.3}{t_1} \log_{10} \left(\frac{P_0(P_s - P_1)}{P_1(P_s - P_0)} \right)$$

Example

- The population of a city in three consecutive years i.e., 1991, 2001 and 2011 is 80,000; 250,000 and 480,000, respectively. Determine (a) The saturation population, (b) The equation of logistic curve, (c) The expected population in 2021.

It is given that

$$P_0 = 80,000 \quad t_0 = 0$$

$$P_1 = 250,000 \quad t_1 = 10 \text{ years}$$

$$P_2 = 480,000 \quad t_2 = 20 \text{ years}$$

The saturation population can be calculated by using equation

$$\begin{aligned} P_s &= \frac{2P_0P_1P_2 - P_1^2(P_0 + P_2)}{P_0P_2 - P_1^2} \\ &= \frac{2 \times 80,000 \times 250,000 \times 480,000 - 250,000 \times 250,000 \times (80,000 + 480,000)}{80,000 \times 480,000 - 250,000 \times 250,000} \\ &= 655,602 \end{aligned}$$

$$\text{We have } m = \frac{P_s - P_0}{P_0} = \frac{655,602 - 80,000}{80,000} = 7.195$$

$$\begin{aligned} n &= \frac{2.3}{t_1} \log_{10} \frac{P_0(P_s - P_1)}{P_1(P_s - P_0)} \\ &= \frac{2.3}{10} \log_{10} \left[\frac{80,000(655,602 - 250,000)}{250,000(655,602 - 80,000)} \right] \\ &= -0.1488 \end{aligned}$$

Population in 2021

$$\begin{aligned} P &= \frac{P_s}{1 + m \log_e^{-1}(n.t)} \\ &= \frac{655,602}{1 + 7.195 \times \log_e^{-1}(-0.1488 \times 30)} \\ &= \frac{655,602}{1 + 7.195 \times 0.0117} = 605,436 \end{aligned}$$

Example :

The population of a town as per the senses records are given below for the years 1945 to 2005. Assuming that the scheme of water supply will commence to function from 2010, it is required to estimate the population after 30 years, i.e. in 2040 and also, the intermediate population i.e. 15 years after 2010.

Year	Population
1945	40185
1955	44522
1965	60395
1975	75614
1985	98886
1995	124230
2005	158790

Solution :

1- **Arithmetic increase method:** Increase in population from 1945 to 2005 , i.e.

for 6 decades: $158800 - 40185 = 118615 = \text{total increment}$

Increase per decade = $118615 / \text{no. of decade} = 118615 / 6 = 19769$

$$p_t = p_o + k\Delta t$$

$$\begin{aligned} p_{2025} &= p_{2005} + (19769)(2) \\ &= 158800 + (19769)(2) \\ &= 198338, \text{capita} \end{aligned}$$

$$\begin{aligned} p_{2040} &= p_{2005} + (19769)(3.5) \\ &= 158800 + (19769)(3.5) \\ &= 227992, \text{capita} \end{aligned}$$

Year	Population	Increase
1945	40185	-----
1955	44522	$44522 - 40185 = 4337$
1965	60395	15873
1975	75614	15219
1985	98886	23272
1995	124230	25344
2005	158800	34570
Total		118615
Average		$118615/6=19769$

2- Geometric increase method :

$$p_t = p_o (1+k)^n$$

Year	Popula tion	Increase	Rate of growth
1945	40185	-----	
1955	44522	44522 – 40185 = 4337	4337 / 40185 = 0.108
1965	60395	15873	0.356
1975	75614	15219	0.252
1985	98886	23272	0.308
1995	124230	25344	0.256
2005	158800	34570	0.278

$$k = \sqrt[6]{0.108 \times 0.356 \times 0.252 \times 0.308 \times 0.256 \times 0.278} = 0.2442$$

$$p_{2025} = p_{2005} (1+0.2442)^2 = 245828, \text{capita}$$

$$p_{2040} = p_{2005} (1+0.2442)^{3.5} = 341166, \text{capita}$$

Factors Influencing the Choice of Forecasting Method

Plausibility

“Do the Outputs Make Sense?”

Face Validity

--Availability of Data

--Quality of Data

“Are the Inputs Good?”

Political Acceptability

“Are the Outputs Acceptable?”

Resources

--Money

--Personnel

--Time

“Can we afford it?”

Needs of the Users

--Geographic Detail

--Demographic Detail

--Temporal Detail

“Are User Needs Satisfied?”

Model Complexity

--Ease of Application

--Ease of Explanation

“Can we do this?”

“Can we explain
what we did?”

Forecast Accuracy

“Is the Forecast Accurate?”

Components of Wastewater Flows

- Domestic wastewater discharges
 - Residential
 - Commercial
 - Institutions
- Industrial Wastewater
- Infiltration/inflow



Water use for public supplies

The details of the domestic consumption are

- a) Drinking — 5 litres
- b) Cooking — 5 litres
- c) Bathing — 55 litres
- d) Clothes washing — 20 litres
- e) Utensils washing — 10 litres
- f) House washing — 10 litres

135 litres/day/capita

Water use distribution

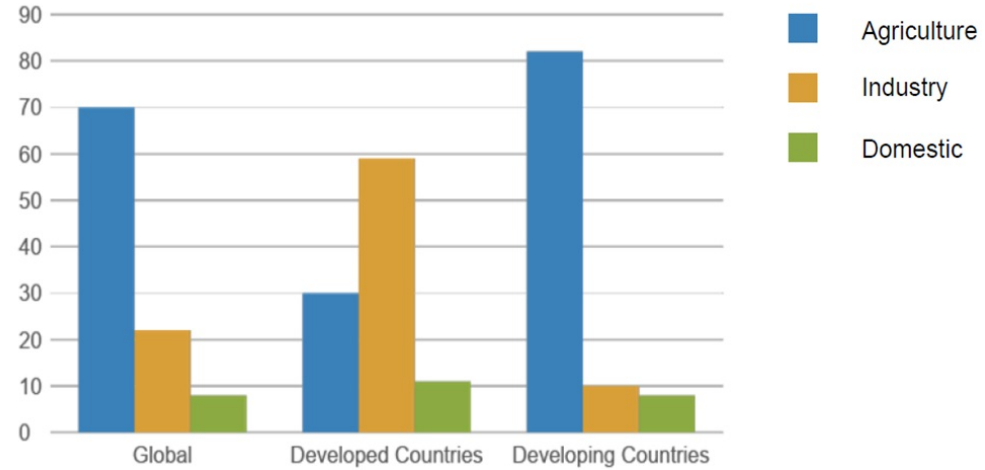

Water - Use Values for Commercial Facilities

User	Flow Range (L / unit . day)
<i>Airport</i>	16 - 20 (<i>passenger</i>)
<i>Automobile Service Station</i>	32 - 60 (<i>vehicle</i>)
<i>Department Store</i>	32 - 55 (<i>employee</i>)
<i>Hotel</i>	160 - 240 (<i>guest</i>)
<i>Motel</i>	100 - 160 (<i>guest</i>)
<i>Laundry</i>	1,600 - 2,100 (<i>machine</i>)
<i>Office</i>	32 - 80 (<i>employee</i>)
<i>Public Lavatory</i>	12 - 24 (<i>user</i>)
<i>Restaurant</i>	60 - 100 (<i>seat</i>)
<i>Shopping Center</i>	32 - 60 (<i>employee</i>)
<i>Theater</i>	8 - 16 (<i>seat</i>)

Water Consumption for Various Purposes:

	Types of Consumption	Normal Range (lit/capita/day)	Average	%
1	Domestic Consumption	65-300	160	35
2	Industrial and Commercial Demand	45-450	135	30
3	Public Uses including Fire Demand	20-90	45	10
4	Losses and Waste	45-150	62	25

Wastewater flowrates variation

- Wastewater flow has daily fluctuations
- Flowrate varies hourly, daily and weekly.
- Peak flow occurs at maximum flow for the day.

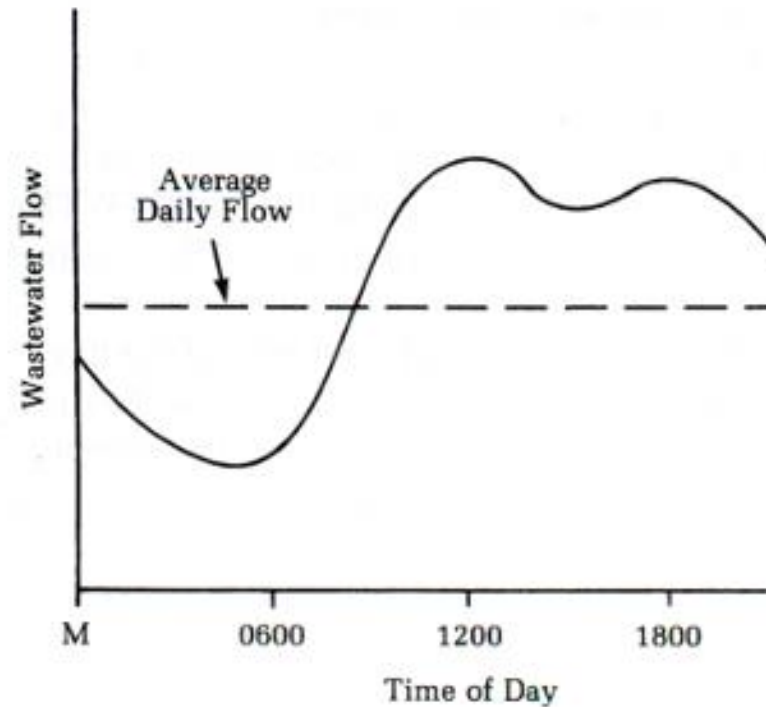

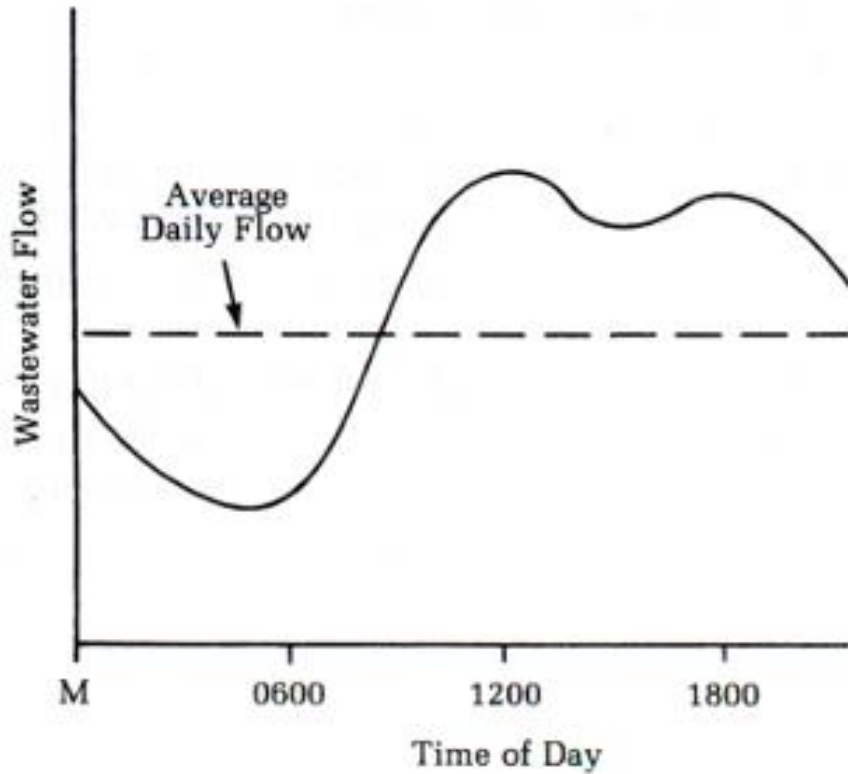

Average daily flow

- It is the average flow occurring over a 24-hour period under dry weather conditions.
- used in evaluating plant capacity, estimating pumping and chemical cost, sludge production, organic loading rates

Maximum daily flow

- It is the maximum flow on a typical dry weather diurnal flow curve.
- used for the design of facilities involving retention time, such as:
 - Equalization basins and Chlorine Contact Tanks

Minimum daily flow

- It is the minimum flow on a typical dry weather diurnal flow curve.
- used in sizing of conduits for minimum deposition

Design average flow

The design average flow is the average of the daily volumes to be received for a continuous twelve (12)-month period expressed as a volume per unit time.

Design maximum daily flow

The design maximum daily flow is the largest volume of flow to be received during a continuous twenty-four (24)- hour period expressed as a volume per unit time.

Wastewater flow quantity

Average flow , Q_{avg}

Q_{avg} is the daily average flow based on yearly data.

Peak flow , Q_{peak}

Peak hourly flow rate of daily average flow ($Q_{peak} = 1.5 \times Q_{max}$ whereas, $Q_{max} = 1.8 \times Q_{avg}$.)

Minimum flow, Q_{min}

Q_{min} is Minimum hourly flow of daily average flow ($Q_{min} = 0.4 * Q_{avg}$).

Normally, the treatment units are designed on the basis of daily average flow while peak and minimum flows are used to check the capacities of basin and conduits in extreme flow condition

Importance of wastewater flow measurement

- Provides data for pollutant mass loading calculations.
- Provides operating and performance data on the wastewater treatment plant.
- Computes treatment costs, based on wastewater volume.
 - Obtains data for long-term planning of plant capacity, versus capacity used.
- Provides information on Infiltration and Inflow (I/I) conditions, and the need for cost-effective I/I correction.
- Affect the hydraulic design of collection and treatment facilities.

Wastewater Treatment Engineering
CE 11401455

Wastewater sewer system: analysis and design

Sewage versus Wastewater - Definitions



© Steve Duncan / Barcroft Media

A brick-built sewer chamber under Clapham High Street in south London

Sewer: Sewers are under ground pipes or conduits which carry sewage to points of disposal.

Sewage: The Liquid waste from a community is called sewage. Sewage is classified into domestic and non-domestic sewage. The non domestic sewage is classified into industrial, commercial, institutional and any other sewage that is not domestic.

Sewerage: The entire system used for collection, treatment and disposal of Liquid waste. This includes pipes, manholes, and all structures used for the above mentioned purposes.

Infiltration: It is the water which inters the sewers from ground water through Leaks from loose joints or cracks.

Inflow: It is the water which inters the sewers from the manholes during rainfall events.

What is sewer system

- A piped system to transport wastewater (and sometimes storm water) from the source (households, industry, runoff) to a treatment facility.
- There are several designs, depending on topography, amount and kind of wastewater, size of community, etc.



- In many countries around the world, flush toilets and sewer systems are the common sanitary systems.
- However, there are several possibilities to keep your wastewater low and provide a sustainable treatment:

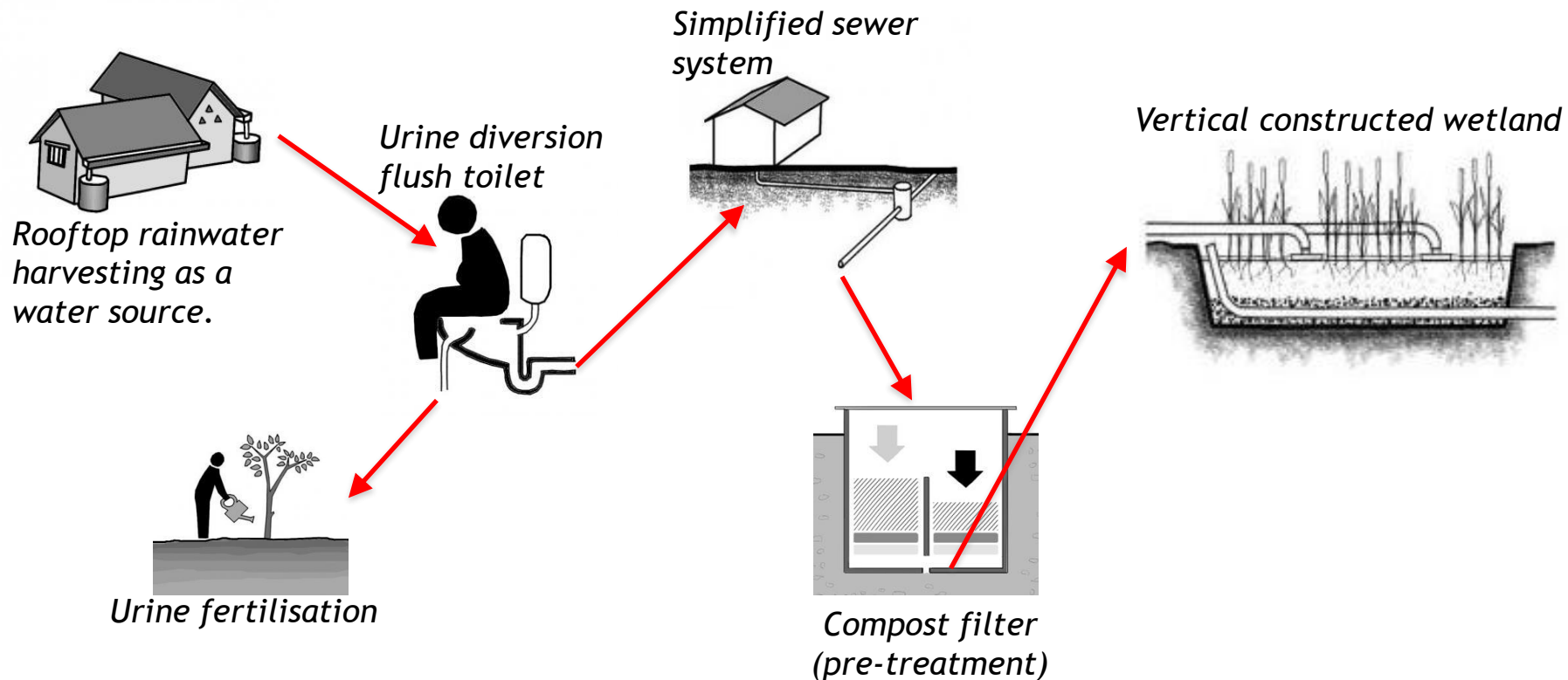

Urine-diverting dry toilet (UDDT)

A urine-diverting dry toilet (UDDT) is a type of dry toilet with urine diversion that can be used to provide safe, affordable sanitation in a variety of contexts worldwide.

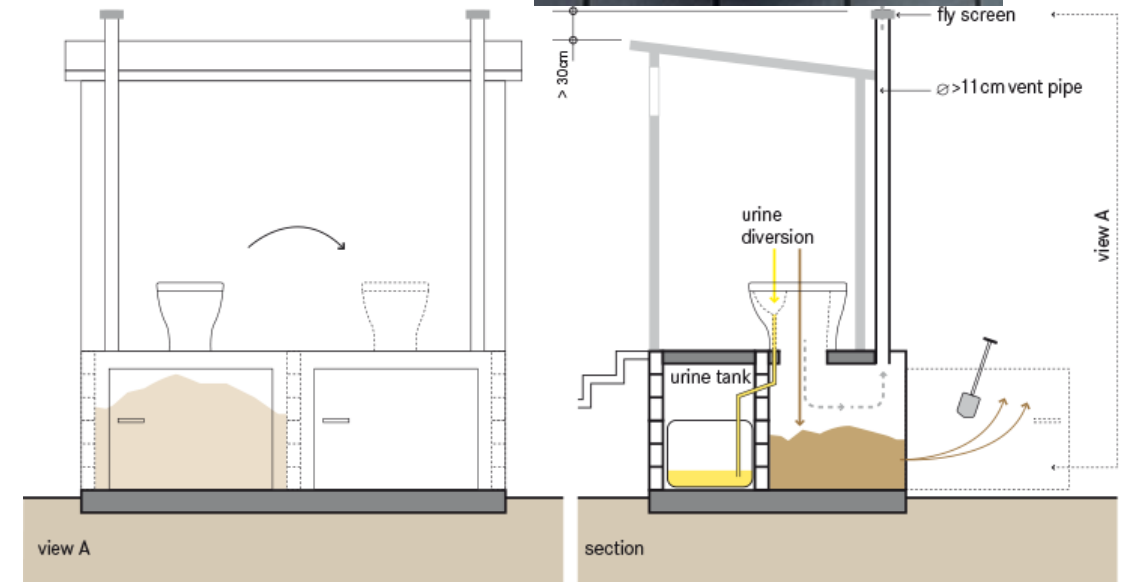

Schematic of the dehydration vaults of a UDDT

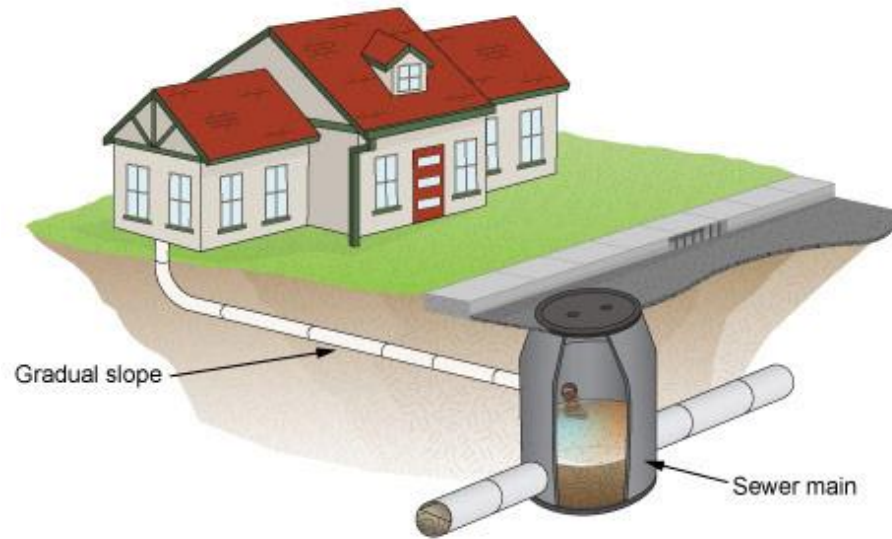

Gravity Systems – Conventional *

Gravity sewerage systems are the traditional method of sewage disposal. These systems take advantage of the natural slope of the ground to collect wastewater, take it away from the property and allow it to flow to the authority sewerage network. The network system transports the wastewater to the treatment plant.

Cont. conventional sewer

- Large networks of underground pipes, mostly in urban areas.
- Collection of blackwater, brown water, greywater and stormwater.
- The system contains three types of sewer lines:
 - Main line (primary): the centre of the system, all other lines empty into it.
 - Branch lines (secondary): extend from the main.
 - House laterals (tertiary): bring wastewater from the houses to the branch lines.

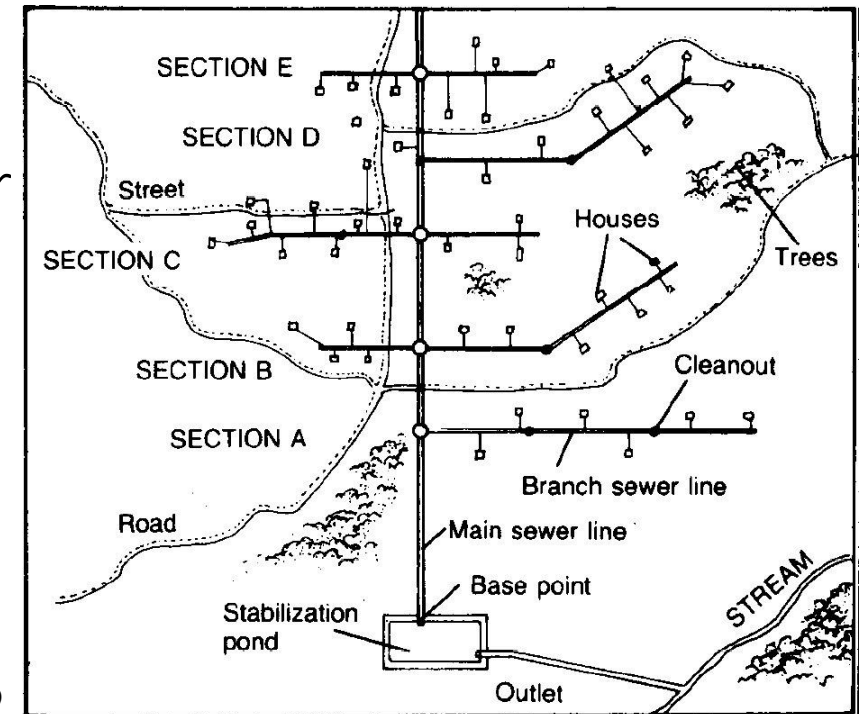

Master sewer system map.
Source: USAID (1982)

RECYCLING WATER



Clean Water

*Springs, wells,
purified water,
city water, rain water*



Greywater

*Used water without
toxic chemicals
and/or excrement*



Blackwater

*Contaminated water
with toxic chemicals
and/or excrement*

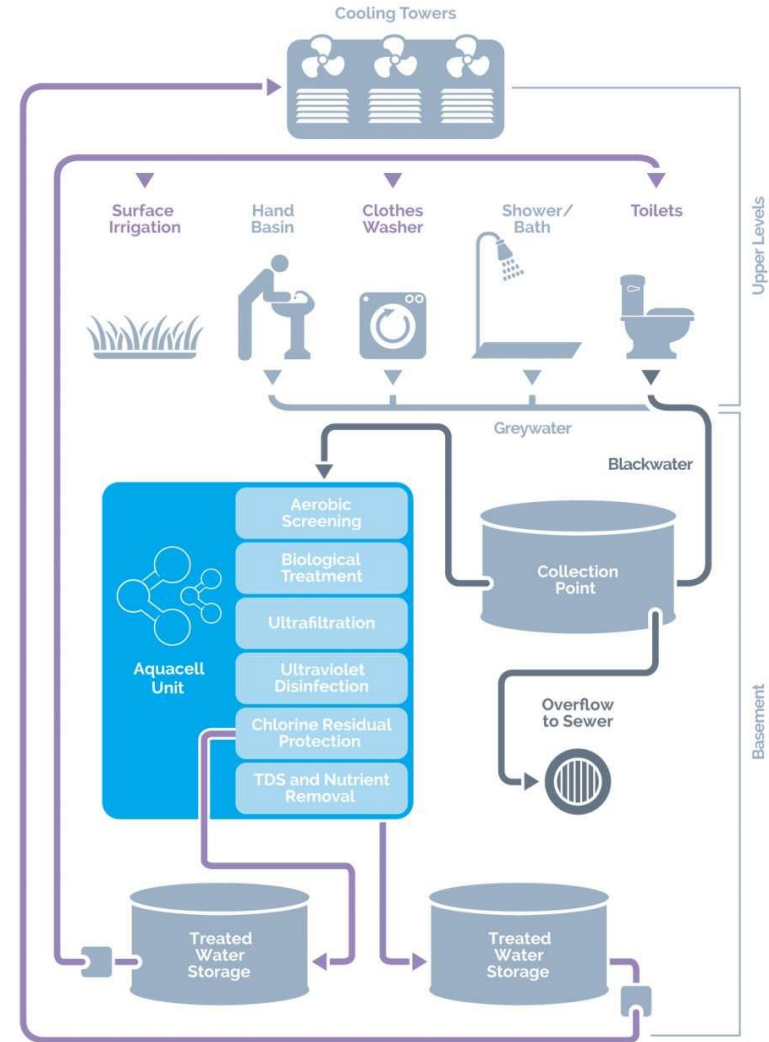

Design

- Wastewater is transported to a centralised treatment facility by gravity.
- Depending on topography, sewer pumping stations are necessary.
- The lines are in a depth of 1.5 to 3 m and manholes provide access for maintenance.
- It must be designed to maintain “self-cleansing” velocity that no particles accumulate

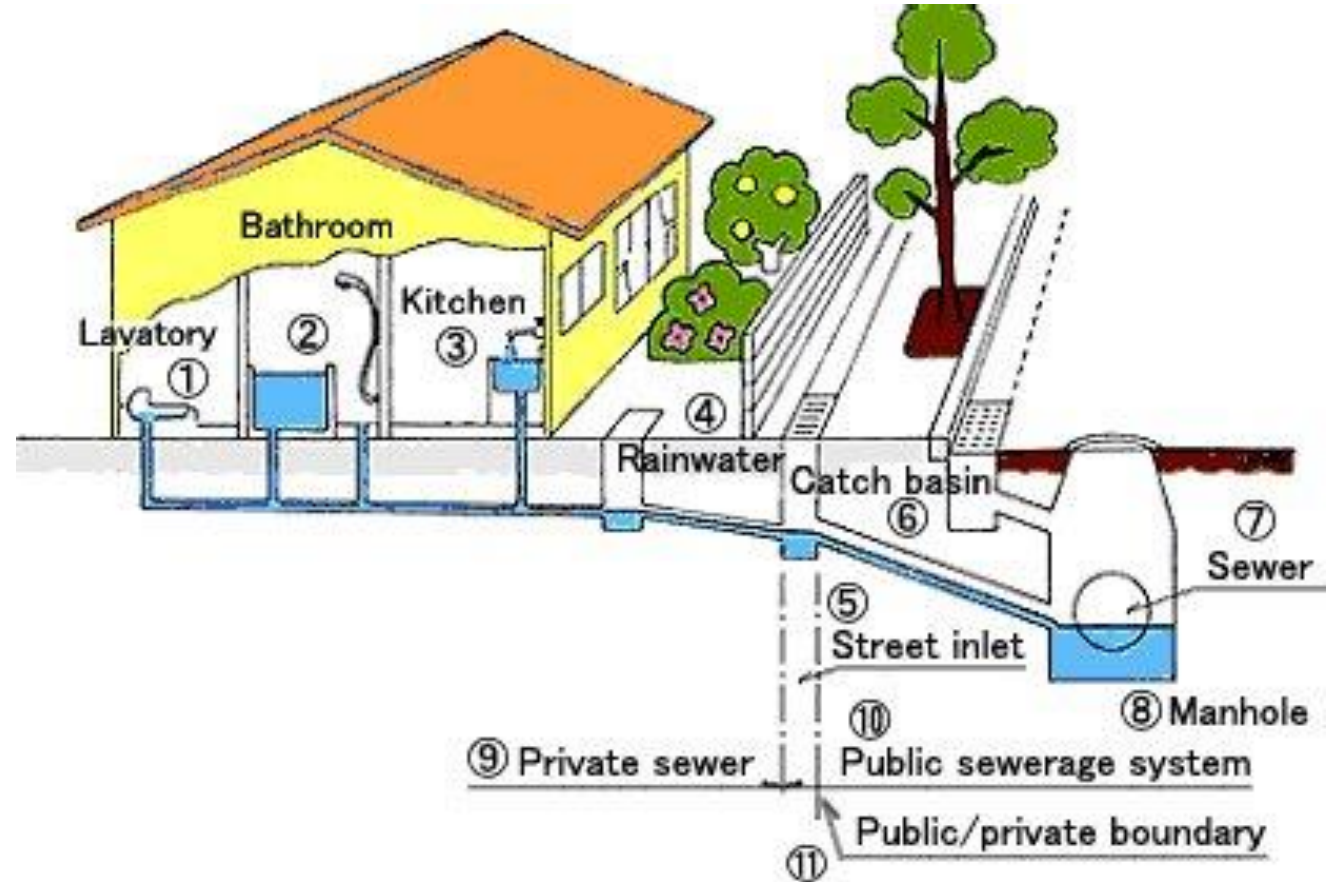

Cross-section of a conventional sewer in a common urban set-up.

Cost

Initial costs are high because:

- Excavation and refilling of trenches to lay the pipes;
- Requires specialised engineers and operators;
- Maintenance costs are high compared to decentralised systems;
- Extension of the system can be difficult and costly (redesign of the whole system)



Pressurized sewer



- This system is not dependent on gravity to move wastewater
- Shallow trenches and relatively small pipe diameters
- Requires permanent electricity and grinder pumps
- system is independent from land topography and does not need deep excavation work.

Cont. Low-pressure sewer

- Low-pressure sewer systems are a low-head pressure wastewater collection and treatment system. They are an alternative to gravity sewer systems or septic tanks.
- A low-pressure sewer system consists of an interceptor tank and a chamber unit, which houses a small, submersible electrical pump. The tank is installed below ground, much like a septic tank. Substantial organic waste treatment occurs in the interceptor tank. The liquid in the tank, or effluent, is pumped automatically through a small pressure line that transports it to a wastewater plant for treatment.

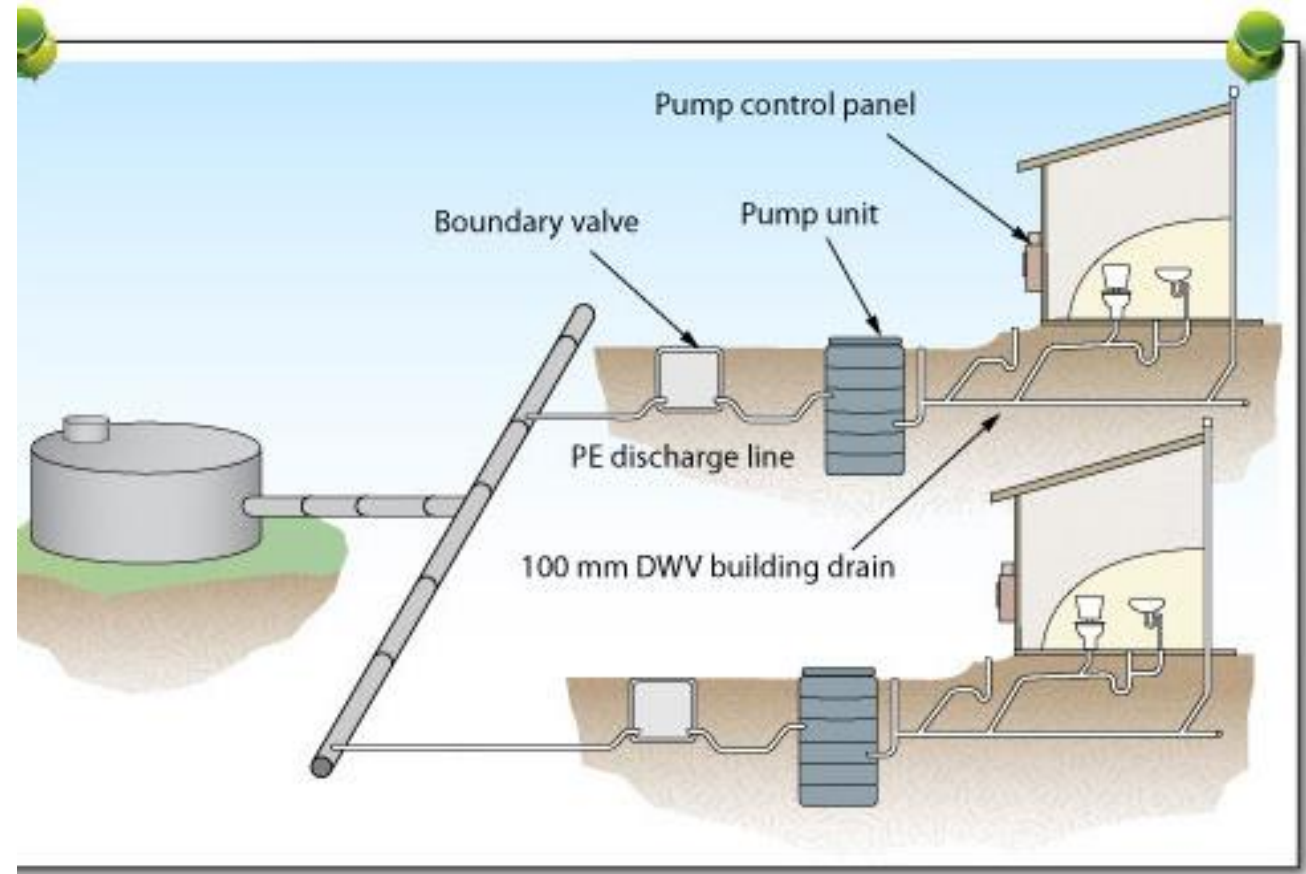

Vacuum sewer

A central vacuum source conveys sewage from individual households to a central collection station. (UNEP 2002)

Use of differential air pressure (“negative pressure” or “vacuum”) to move the sewage.

A central source of power to operate vacuum pumps is required to maintain vacuum.

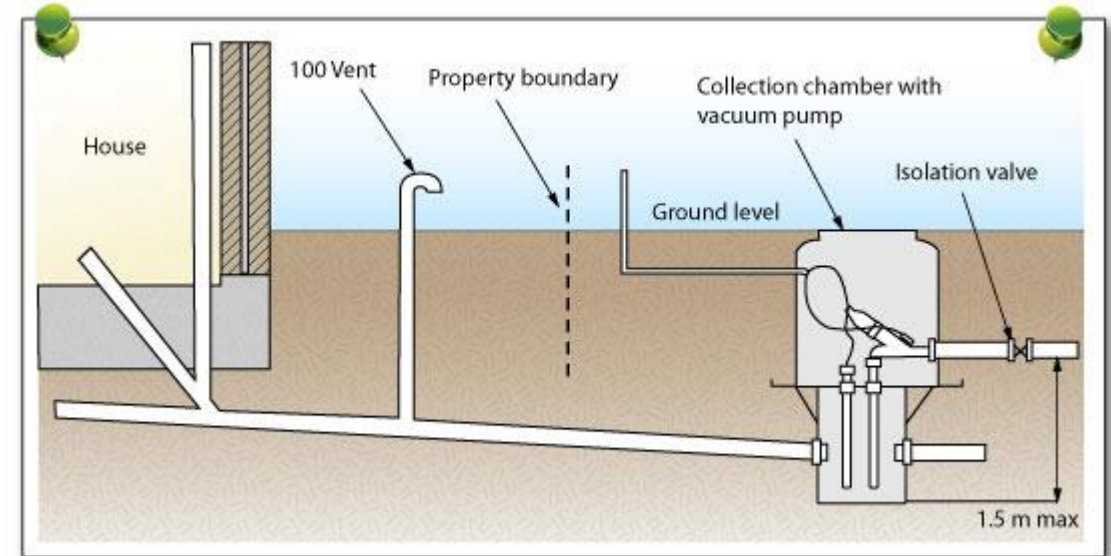

Categories of Sewer Systems

- Separate Sewer Systems
- Combined Sewer Systems

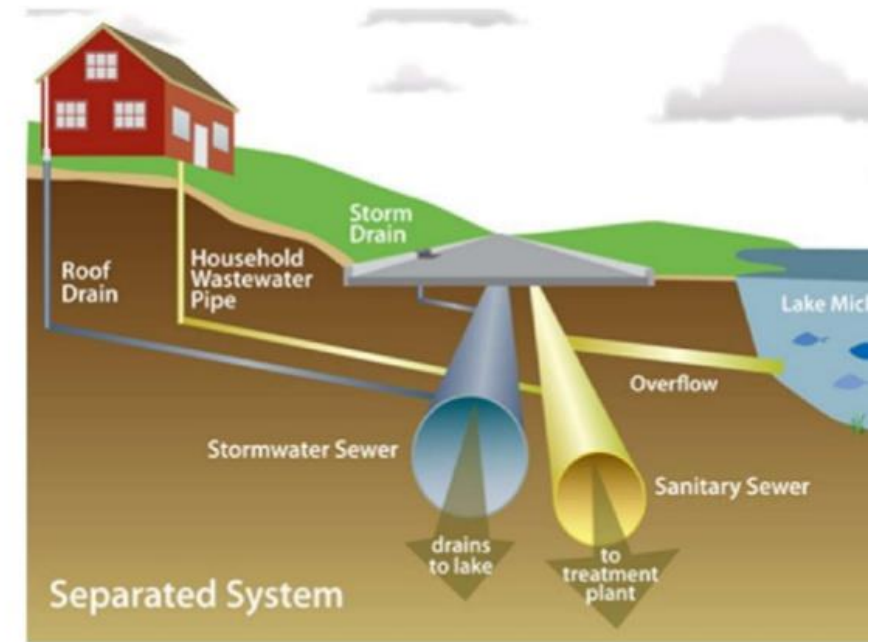
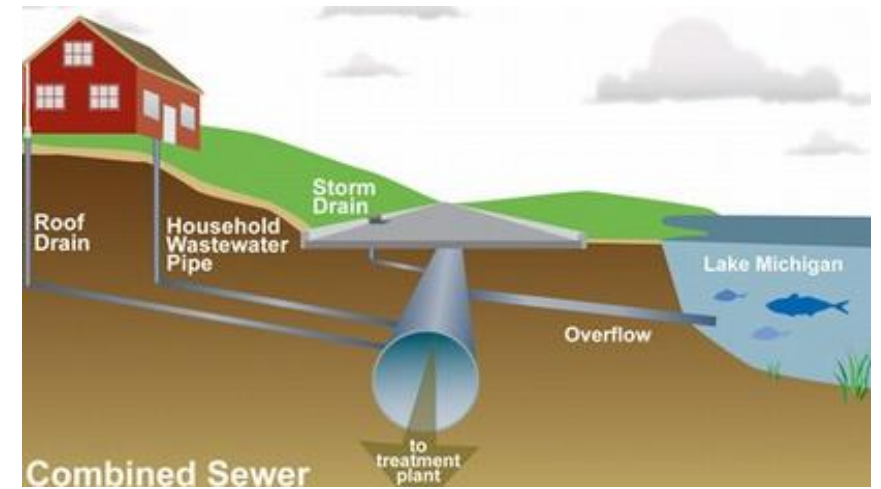

Separate sewer system

Design principle

- In contrast to conventional sewer systems, wastewater (e.g. from households or industries) and stormwater are transported separately.

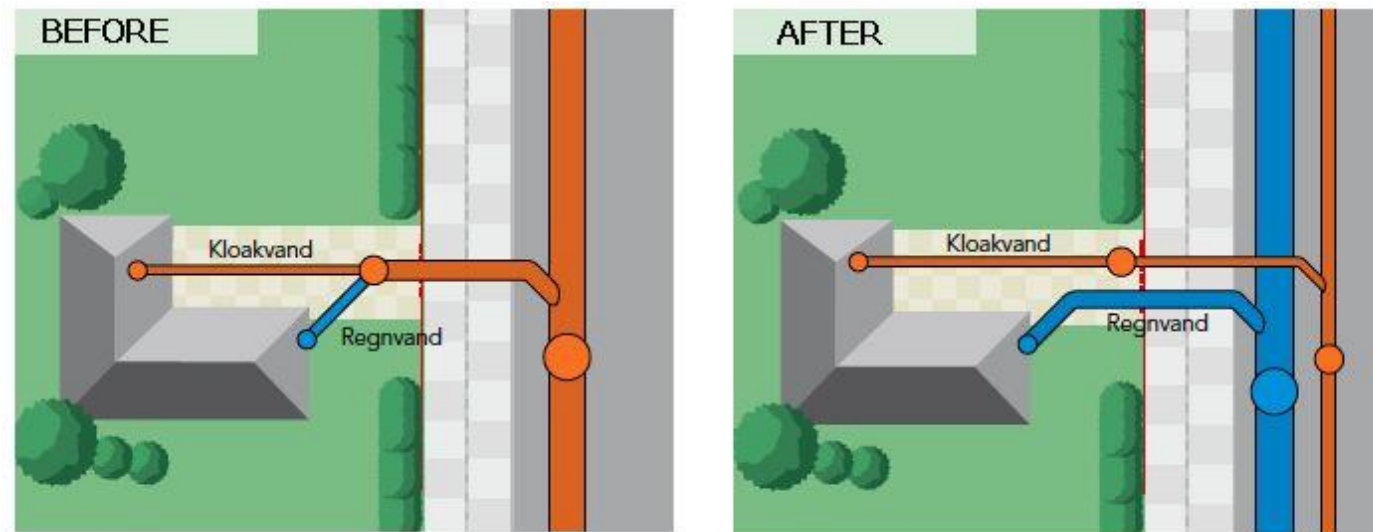

- During heavy rains, overflow contains no harmful blackwater.
- Stormwater in general is less contaminated. Source: UNEP and MURDOCH 2004

Cont. Separated sewer systems

Cost

- Construction costs might be higher than for the combined sewer system because two separated networks are necessary.
- They must also be maintained and operated separately.
- A replacement of a combined system by a separated system is very costly.

Operation and maintenance

- Same as conventional systems

Cont. Separated sewer systems

- Suitable for urban areas that have the resources to implement, operate and maintain such systems plus provide adequate treatment to avoid pollution at the discharge end.
UNEP (2002)
- Enough water for transportation must be available.
- Especially suitable during monsoon → large amounts of stormwater can be treated separately.



New construction of a separated sewer system in Germany.

Advantages of separate sewer systems

- The cost of installation is low compared to combined systems.
- The load on the treatment units will be lowered, since only the foul sewage carried by the separate sewers need be treated.
- There is no necessity of providing automatic flushing tanks, for use in dry weather, because the flow in a sewer of smaller section is much more efficient.
- Sewers of smaller section can be easily ventilated than those of larger section.
- The night flow will be comparatively small this may facilitate operations at the outfall works.
- Rain water can be discharged into streams or rivers without any treatment.

DISADVANTAGES!

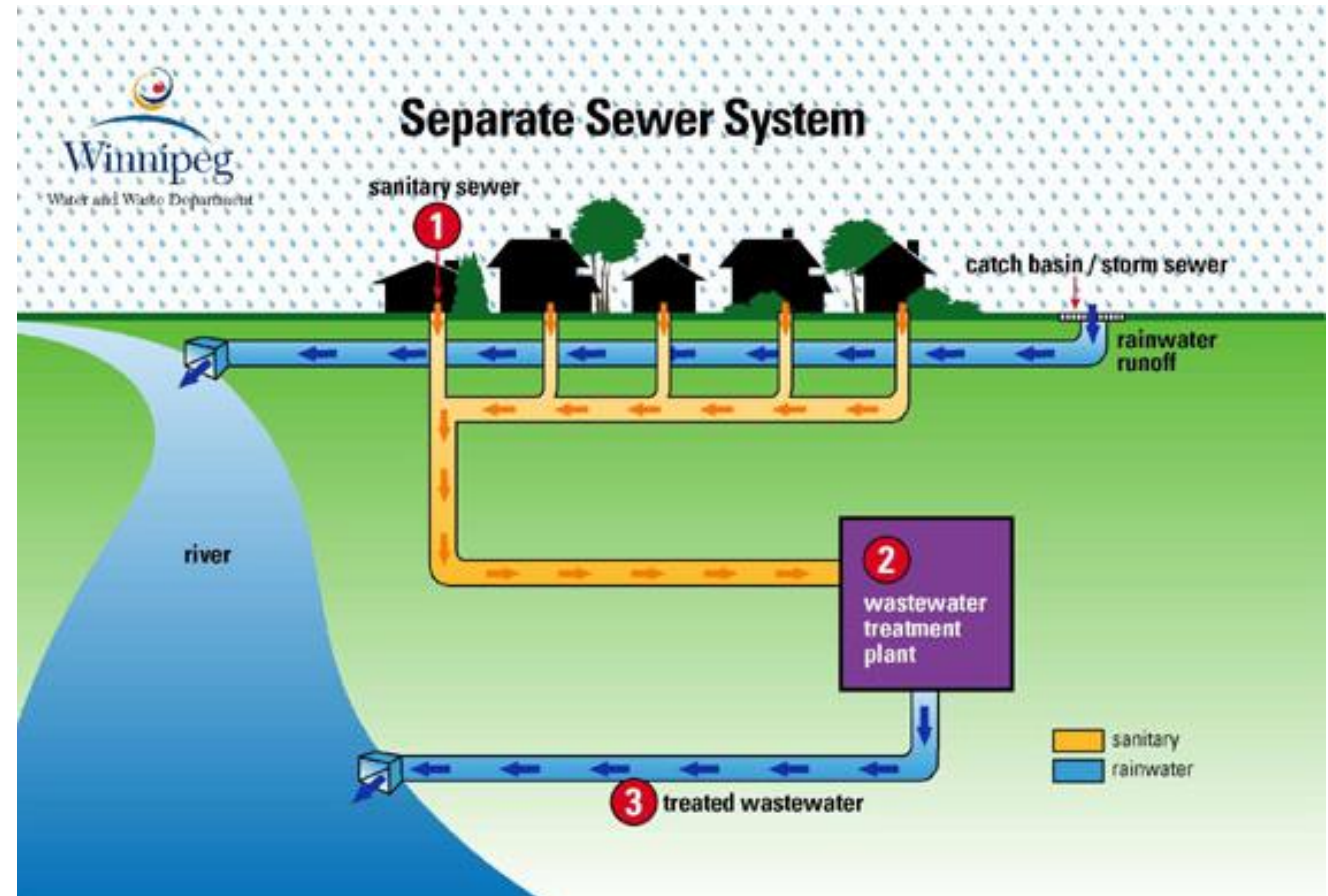

Cont. Separated sewer systems

•Advantages:

- Surface run-off, greywater and blackwater can be managed separately
- Limited of sewage overflow
- Low health risk
- No nuisance from smells, mosquitoes or flies
- No problems related to discharging industrial wastewater
- Moderate operation costs
- Surface run-off and rainwater can be reused

Disadvantages:

- Supply of piped water
- Difficult to construct in high-density areas, difficult and costly to maintain
- High capital costs
- Requires skilled engineers and operators
- Problems associated with blockages and breakdown of pumping equipment
- Adequate treatment and/or disposal required
- Higher risk of water pollution by accidents

Combined sewer systems

- are large networks of underground pipes that convey domestic sewage, industrial wastewater and stormwater runoff in the same pipe to a centralized treatment facility
- mostly found in urban areas
- do not require on-site pre-treatment or storage of the wastewater Transport all their wastewater to a WWTP where it is treated and discharged to a water body.

Design principles

- Because the wastewater is not treated before it is transported, the sewer must be designed to maintain self-cleansing velocity (i.e. a flow that will not allow particles to accumulate), generally obtained with a minimal flow of 0.6 to 0.75m/s.
- A constant downhill gradient must be guaranteed along the length of the sewer to maintain self-cleansing velocity

Advantages of combined sewer systems

- The system requires only one set of sewers. Hence the maintenance costs are reduced.
- The sewers are of larger size, and therefore the chances of their choking are rate. Also, it is easy to clean them.
- The strength of the sewage is reduced by dilution.
- There is more air in the larger sewers than in smaller ones of the separate system. Hence the sewer gas that may be formed gets diluted. Thus the chances of foul smell are reduced.

DISADVANTAGES!

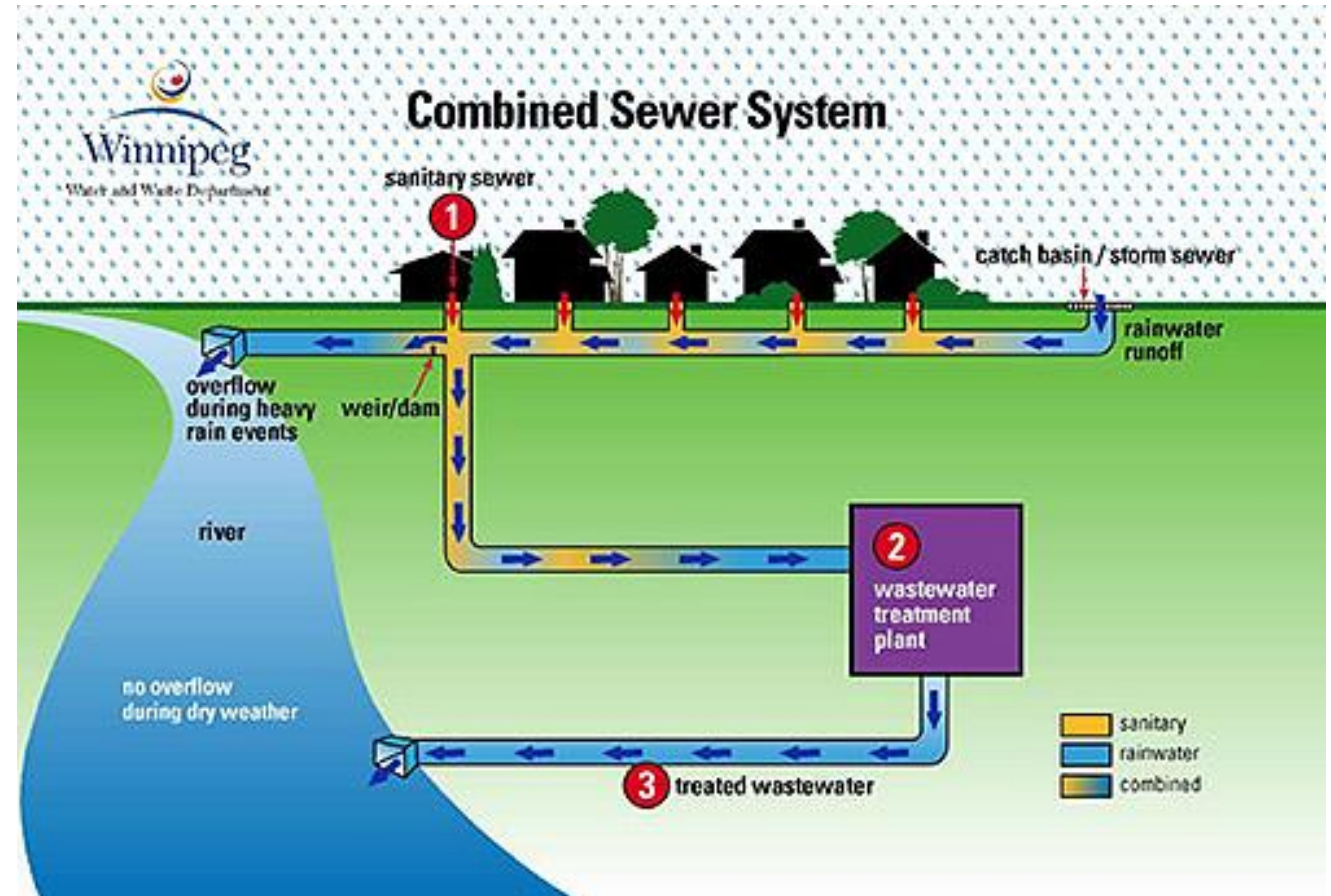

Cont. Combined sewer systems

Advantages	Disadvantages
Convenience (minimal intervention by users)	High capital costs
Low health risk	Need a reliable supply of piped water
No nuisance from smells, mosquitoes or flies	Difficult to construct in high-density areas, difficult and costly to maintain
Stormwater and wastewater can be managed at the same time	Recycling of nutrients and energy becomes difficult
No problems related to discharging industrial wastewater	Unsuitability for self-help, requires skilled engineers and operators
Moderate operation and maintenance costs	Problems associated with blockages and breakdown of pumping equipment
	Adequate treatment and/or disposal required

Design of sewer systems

- Design criteria

Maximum and minimum velocities:

Minimum velocity of 0.6 m/s should be maintained to prevent solids settling, it is called self cleansing velocity.

Maximum velocity should not be greater than 3 m/s to prevent erosion of pipes and manholes.

Minimum size of pipes:

Minimum diameter is 8 inches (20 cm).

Minimum Slope and maximum slope of sanitary sewers:

Minimum slope is a function of the minimum velocity of 0.60 m/s. The maximum slope is related to the maximum velocity (3 m/s or any other velocity selected by the designer) according to the pipe material and the expected amount of sand carried with the wastewater.

Based on Manning equation with a velocity of 0.6 m/s



Minimum slopes for gravity flow sewers

Diameter		Slope m/m	
mm	inch	n=0.013	n=0.015
200	8	0.0033	0.0044
250	10	0.0025	0.0033
300	12	0.0019	0.0026
375	15	0.0014	0.0019
450	18	0.0011	0.0015
525	21	0.0009	0.0012
600	24	0.0008	0.0010
675	27	0.0007	0.0009
750	30	0.0006	0.0008
900	36	0.0004	0.0006

Depth of excavation:

Minimum cover on the top of sewers

Depth of excavation depends on:

water table

topography

lowest point to be served

other factors



D (inch)	Depth below design level (m)
4	0.7
6	0.8
8	1.0
10	1.0
12	1.0
14	1.2
16	1.3

Sewer system design

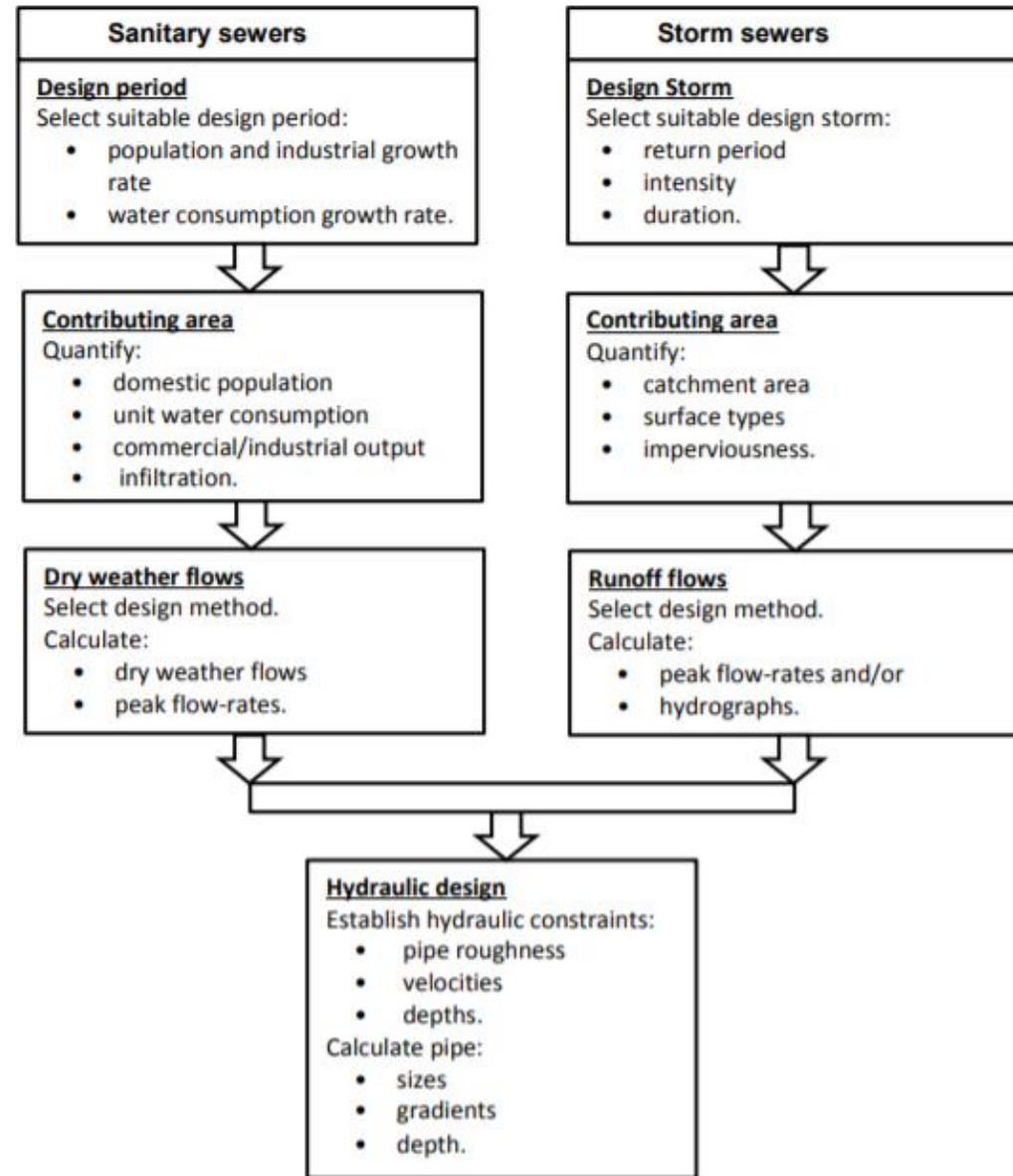

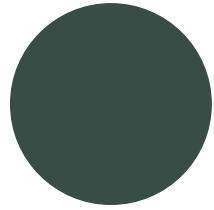
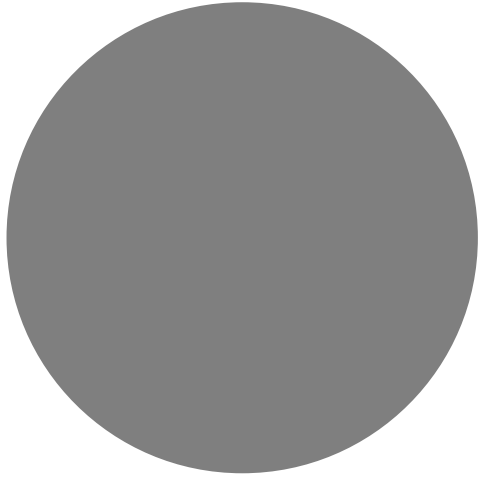

Wastewater Treatment Engineering

CE 11401455

Biological Oxygen Demand (BOD)



Biological Oxygen Demand (BOD)

Definition

- The quantity of oxygen utilised by a mixed population of micro-organisms to biologically degrade the organic matter in the wastewater under aerobic condition.
- Normally, wastewater has high organic content. The organic content are measured by Biochemical Oxygen Demand (BOD) and Chemical Oxygen Demand (COD).
- BOD is used as a measure of organic pollution as a basis for estimating the oxygen needed for biological processes, and as an indicator of process performance.
- The more “food” present in the waste, the more Dissolved Oxygen (DO) will be required.

Aerobic and Anaerobic decomposition

- Aerobic decomposition

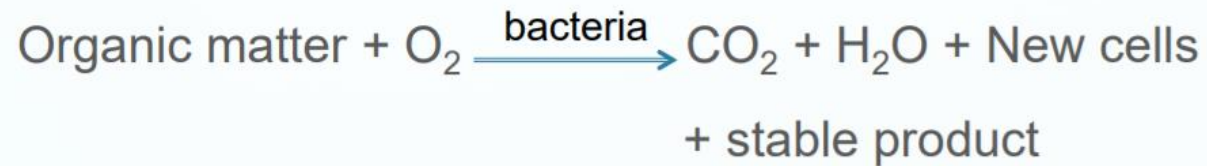

- Anaerobic decomposition

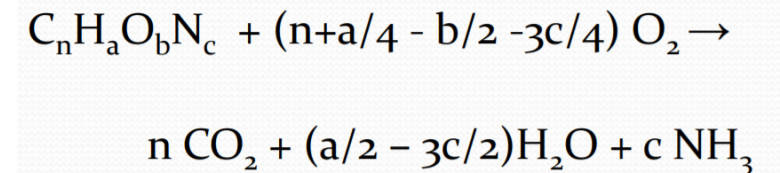
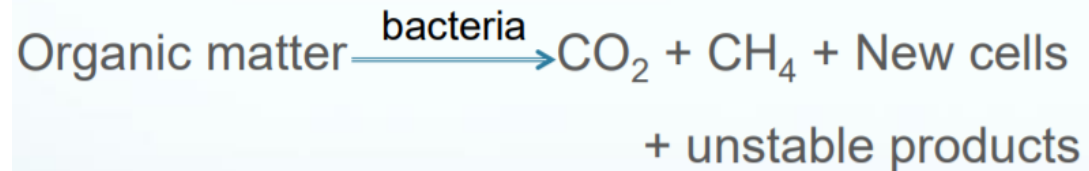

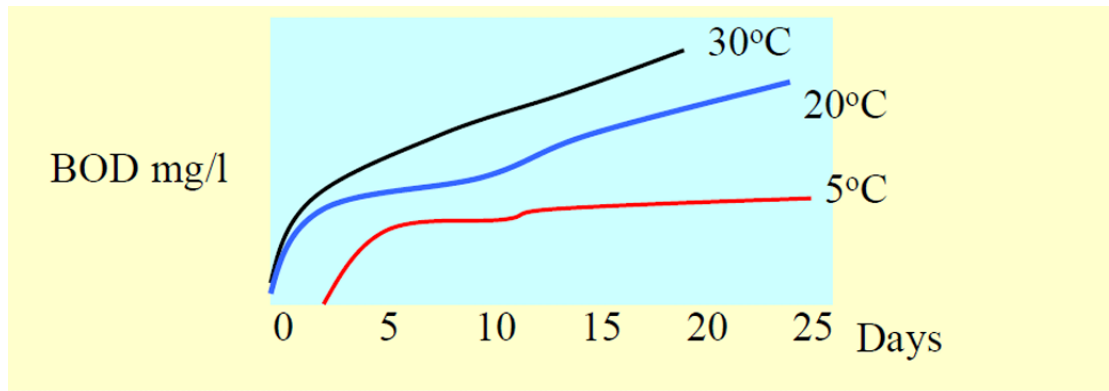

BOD Pyramid

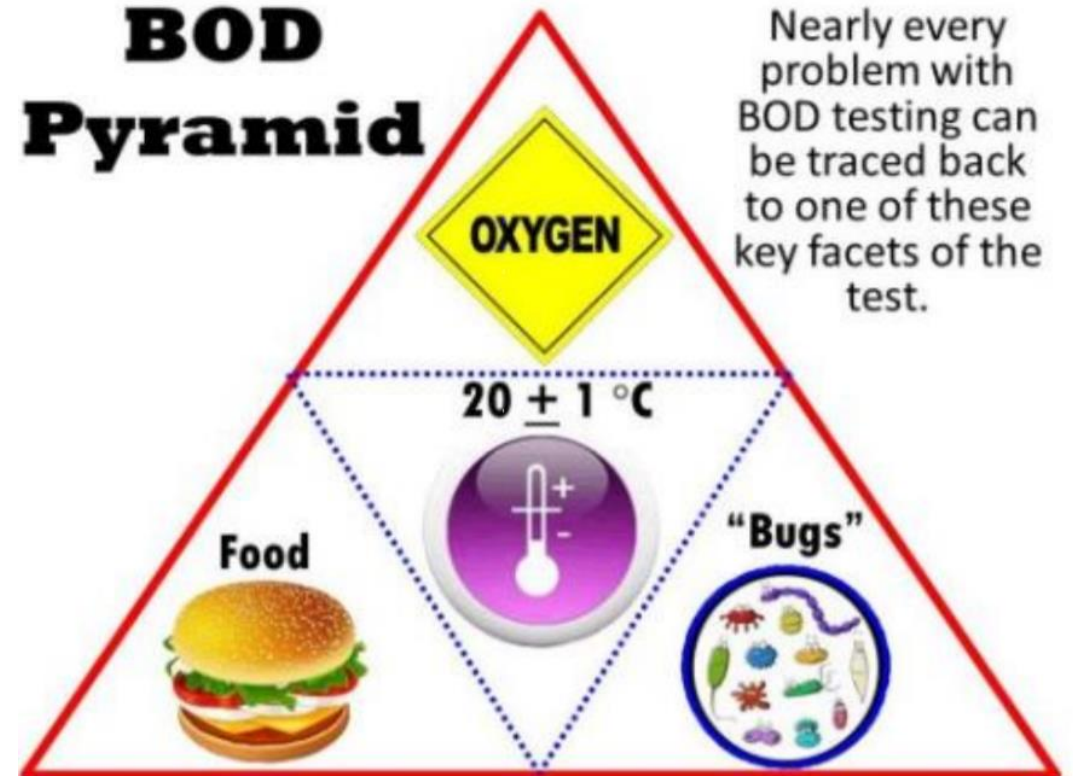

BOD

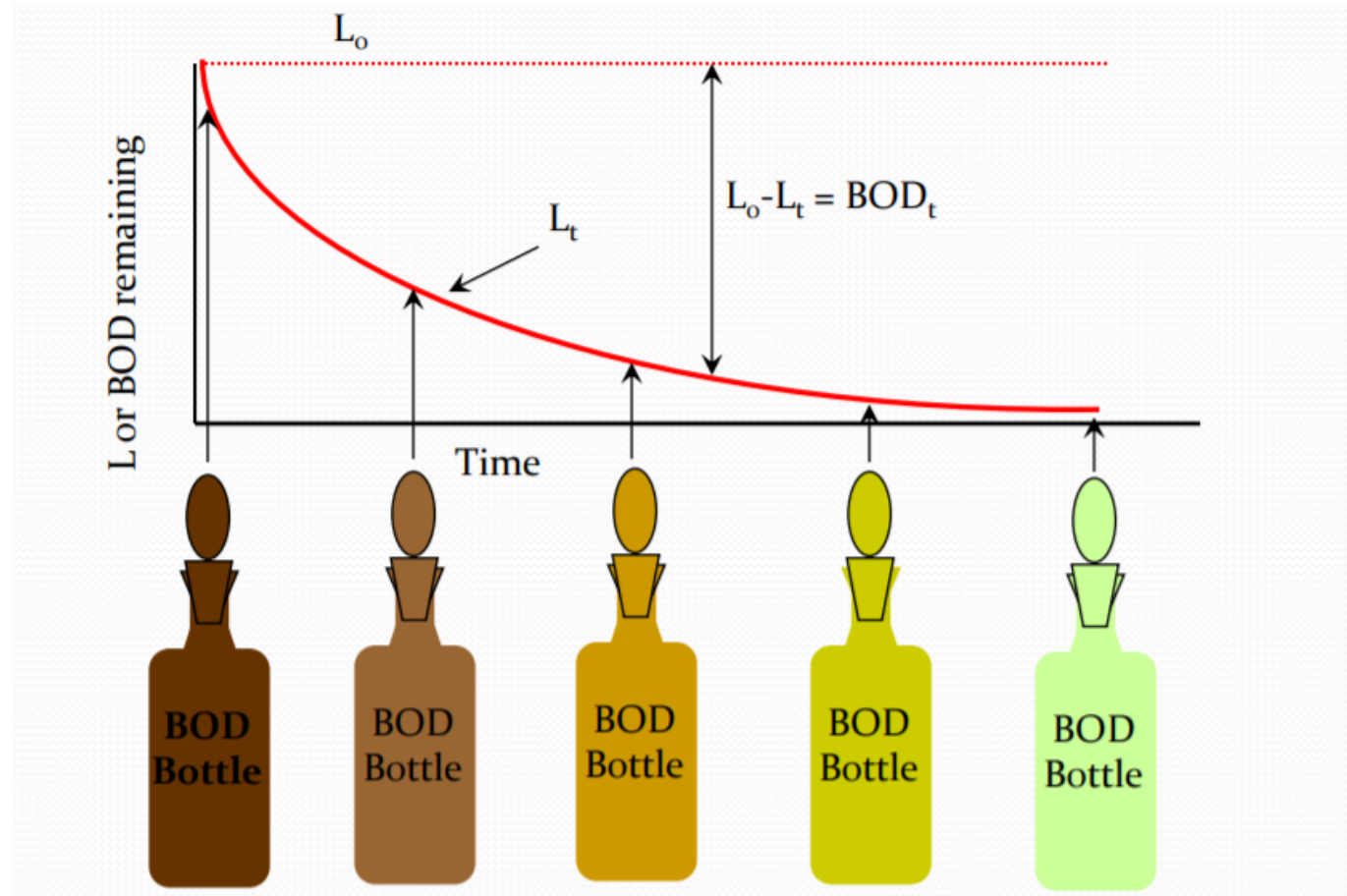

BOD excretion and remaining

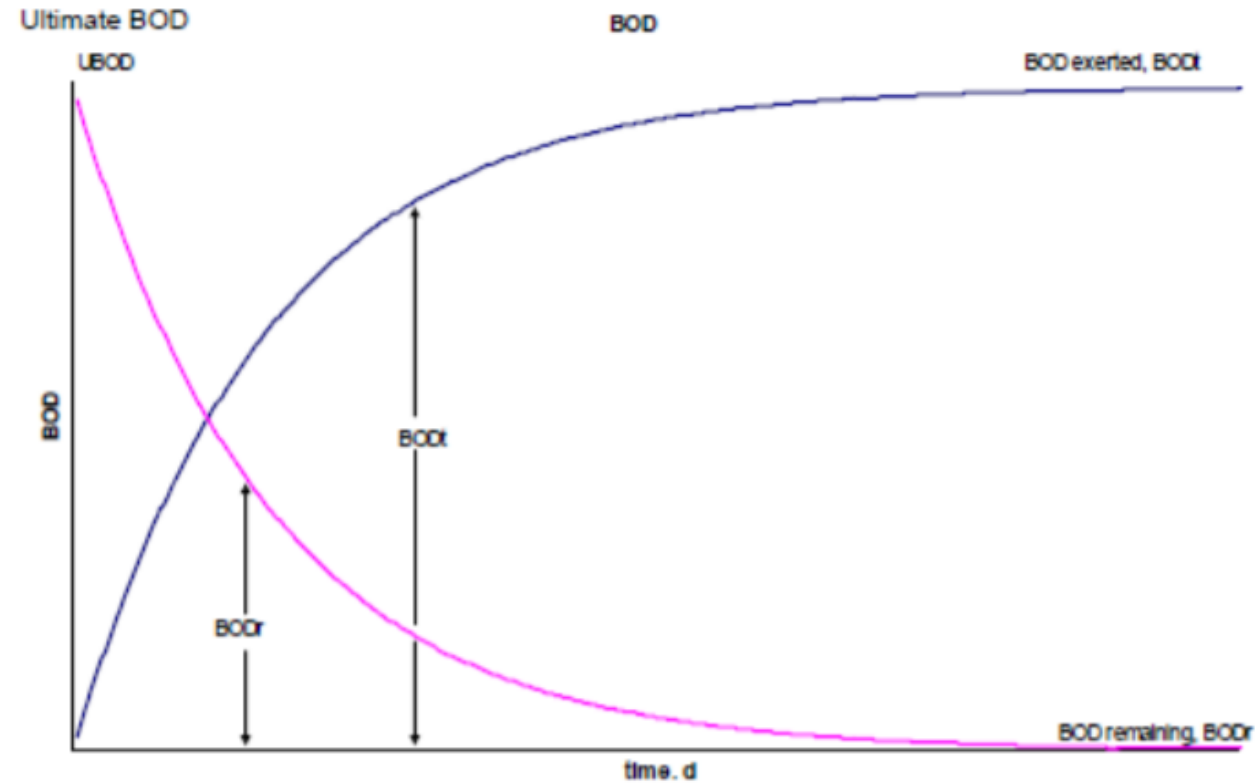

Metcalf & Eddy, 4th edition

BOD, CBOD, NBOD

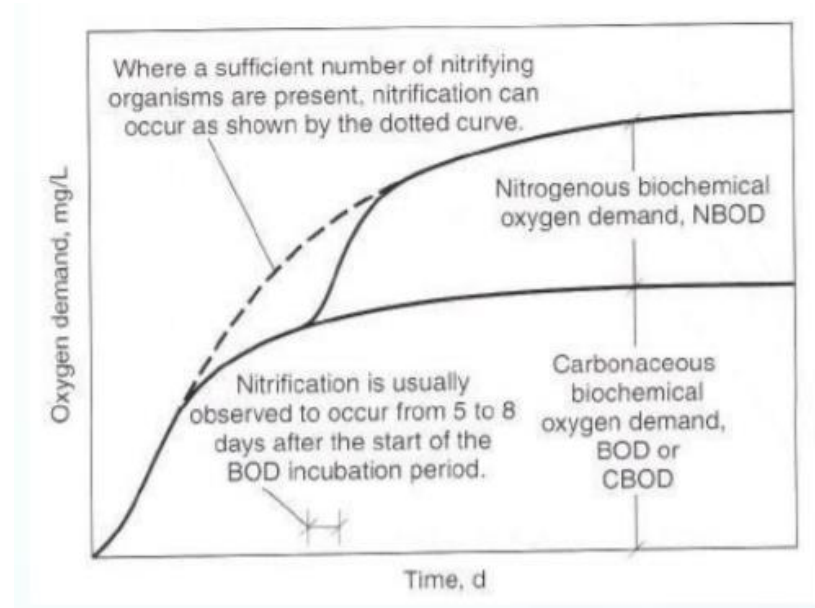
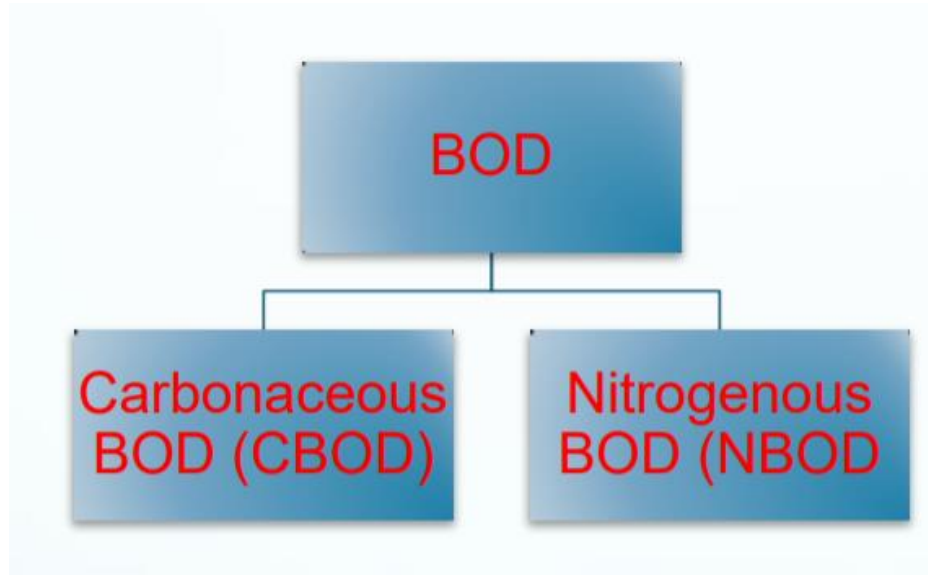

BOD₅

- **BOD₅²⁰**: Biochemical Oxygen Demand, by microbial decomposition in the lab, under standardised conditions:
 - 5 days period
 - 20 ° Celsius
 - in the dark (to prevent algae growth and photosynthesis of O₂)
- Other compounds (than organic matter) can also be converted by microbes while using oxygen. Most common one is NH₄⁺:
- Theoretically: $\text{NH}_4^+ + 2 \text{O}_2 \rightarrow \text{NO}_3^- + 2\text{H}^+ + \text{H}_2\text{O}$
- Nitrogen Oxygen Demand (nBOD) = 4.57 g O₂ / g NH₄-N !
- When no measures are taken to prevent this, the analysis result is called TBOD (total BOD).
- When a so-called nitrification inhibitor is added (prevents conversion of NH₄⁺), then it is called CBOD (carbon-BOD).

Forms of Nitrogen in Wastewater

- **Inorganic**

Ammonia – NH₃

Nitrite – NO₂⁻

Nitrate – NO₃⁻

- **Organic**

Complex Compounds

Protein (plant & animal)

Amino Acids

etc.



Ammonia – NH₃

Toxic

Oxygen Demand

Nitrite – NO₂⁻

Chlorine Demand

Nitrate – NO₃⁻

Health Concern



Forms of Nitrogen in Wastewater

Total Kjeldahl Nitrogen - "TKN"

Sum of
Organic N + Ammonia

Total Inorganic Nitrogen - "TIN"

Sum of
Ammonia + Nitrite + Nitrate

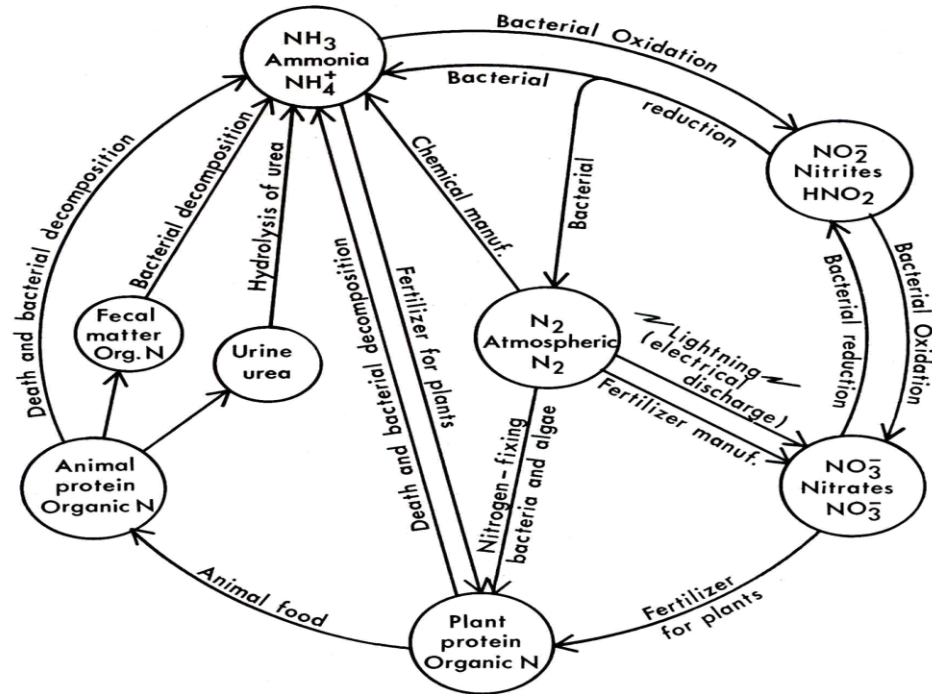

Nitrification

- Biological Oxidation of Ammonia to Nitrite to Nitrate

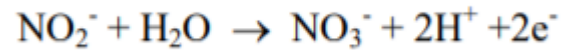

*Autotrophic Bacteria Utilize Inorganic Compounds
(and CO_2 as a Carbon Source)

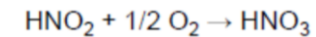
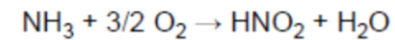
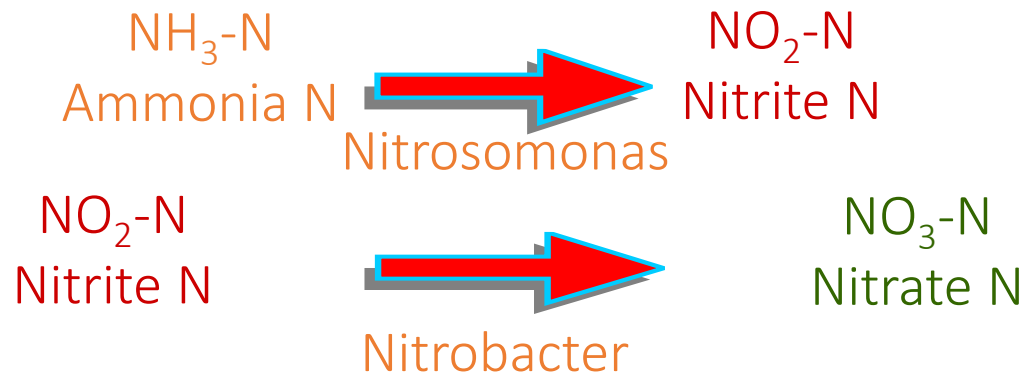

Oxygen requirements of Nitrogen

- Air Requirements

1.5 lbs O₂ / lb BOD

4.6 lbs O₂ / lb TKN

- Lower temperatures cause slower nitrifier growth

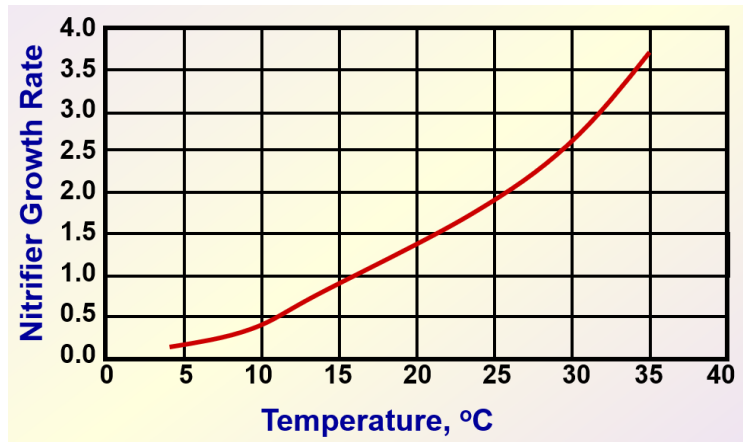

BOD test – without dilution



$$\text{BOD}_5 = (\text{DO}_0 - \text{DO}_5) \text{ mg/L}$$

BOD test – with dilution

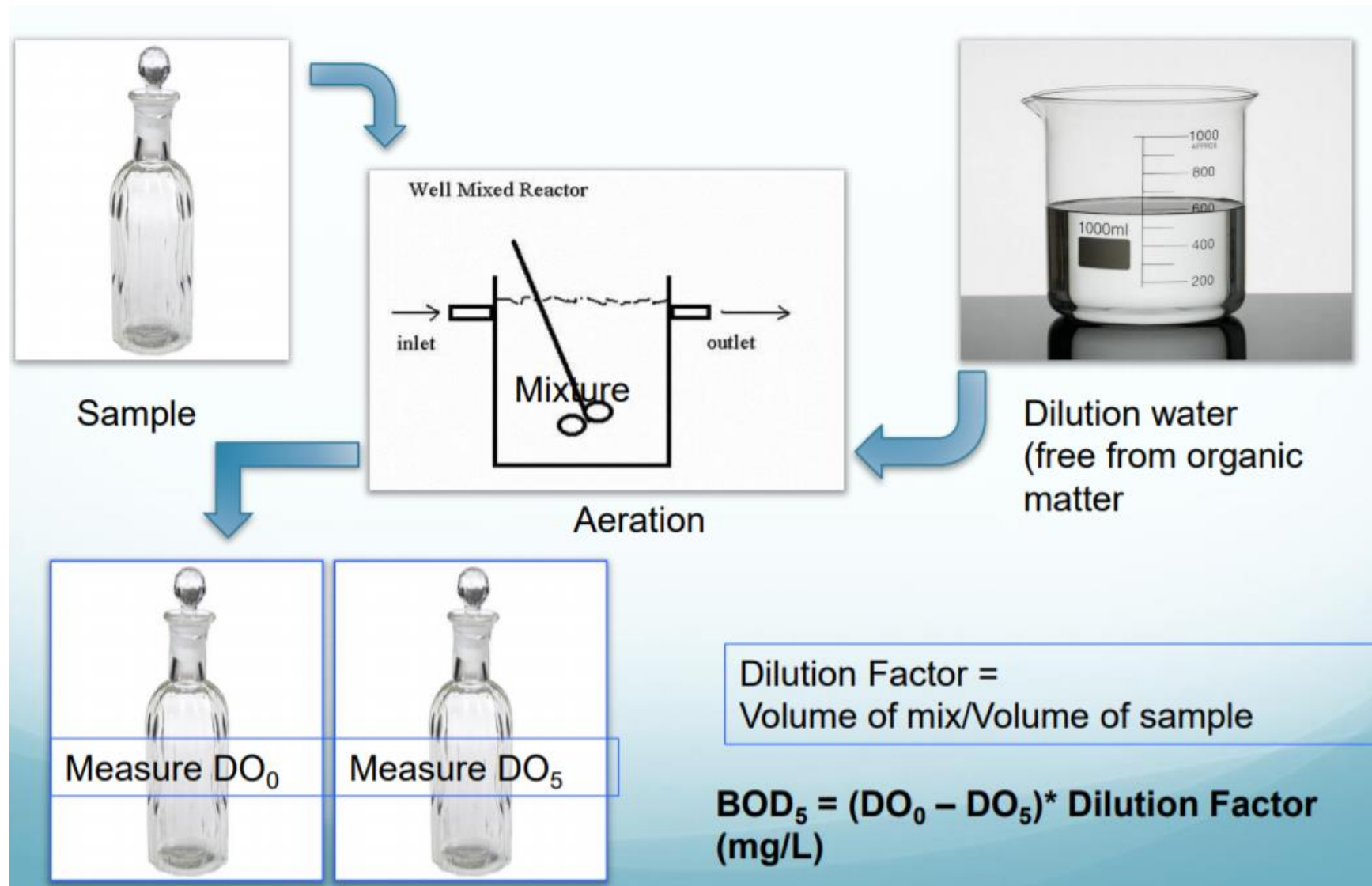

Chemical Oxygen Demand (COD)

- In practice, to avoid 5 days delay between sampling and obtaining result:
- **COD**: Chemical Oxygen Demand; oxidation by strong chemical oxidant, usually $\text{K}_2\text{Cr}_2\text{O}_7$ (potassium dichromate) in the presence of sulfuric acid (**Assignment : Why!!**) at elevated temperatures ($\sim 150\text{ }^\circ\text{C}$), during 2 hours
- For various types of (waste)waters, there is usually a more or less constant ratio between BOD and COD:
 - domestic wastewater: $\text{BOD}/\text{COD} = 0.65$
 - surface water: $\text{BOD}/\text{COD} = 0.40$

Example (Assignment)

Determine the 5-day BOD for a 15 ml sample that is diluted with dilution water to a total volume of 300 ml when the initial DO concentration is 8 mg/l and after 5 days, has been reduced to 2 mg/l.

BOD Kinetics

Rate of reaction is proportional to the concentration of food:

$$-\frac{dC}{dt} = k'C \quad (23.2)$$

It is customary to describe biodegradable organic matter in terms of its equivalent oxygen consumption potential:

$$-\frac{dL_t}{dt} = k'L_t \quad (23.3)$$

In many cases, the interest is in how much oxygen has been consumed, rather than how much BOD remains:

$$y = (L_0 - L_t) \quad (23.5)$$

$$y = L_0(1 - e^{-k't}) = L_0(1 - 10^{-kt}) \quad (23.6)$$

In the BOD test, it is y which is measured rather than L_t

Reaction Order	Form	Units	Comment on Rate
Zero-order	rate = k	1/time	Concentration has no effect
First-order	rate = kC	Concentration/time	Directly proportional to concentration
Second-order	rate = kC^2	Concentration x Concentration/time	Proportional to second power of concentration

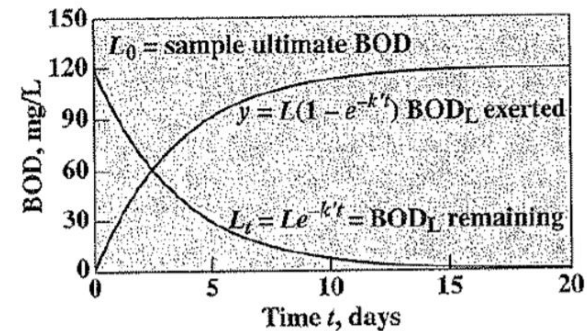

Figure 23.1 Changes in biodegradable organic matter, measured in oxygen equivalents or BOD_L , as a function of time.

BOD kinetics

BOD reactions have “1st order kinetics”

“1st order kinetics” refers to the dependence on concentration

$$\text{Rate} = - \frac{\Delta[\text{react}]}{\Delta\text{time}} = \frac{\Delta[\text{prod}]}{\Delta\text{time}} = k [\text{react}]^1$$

What is k?

k is called the “rate constant”, it’s the only thing that is constant in this kinetic scheme.

- k is temperature-dependent, because microorganisms are more active at high temperature, where k values are higher.

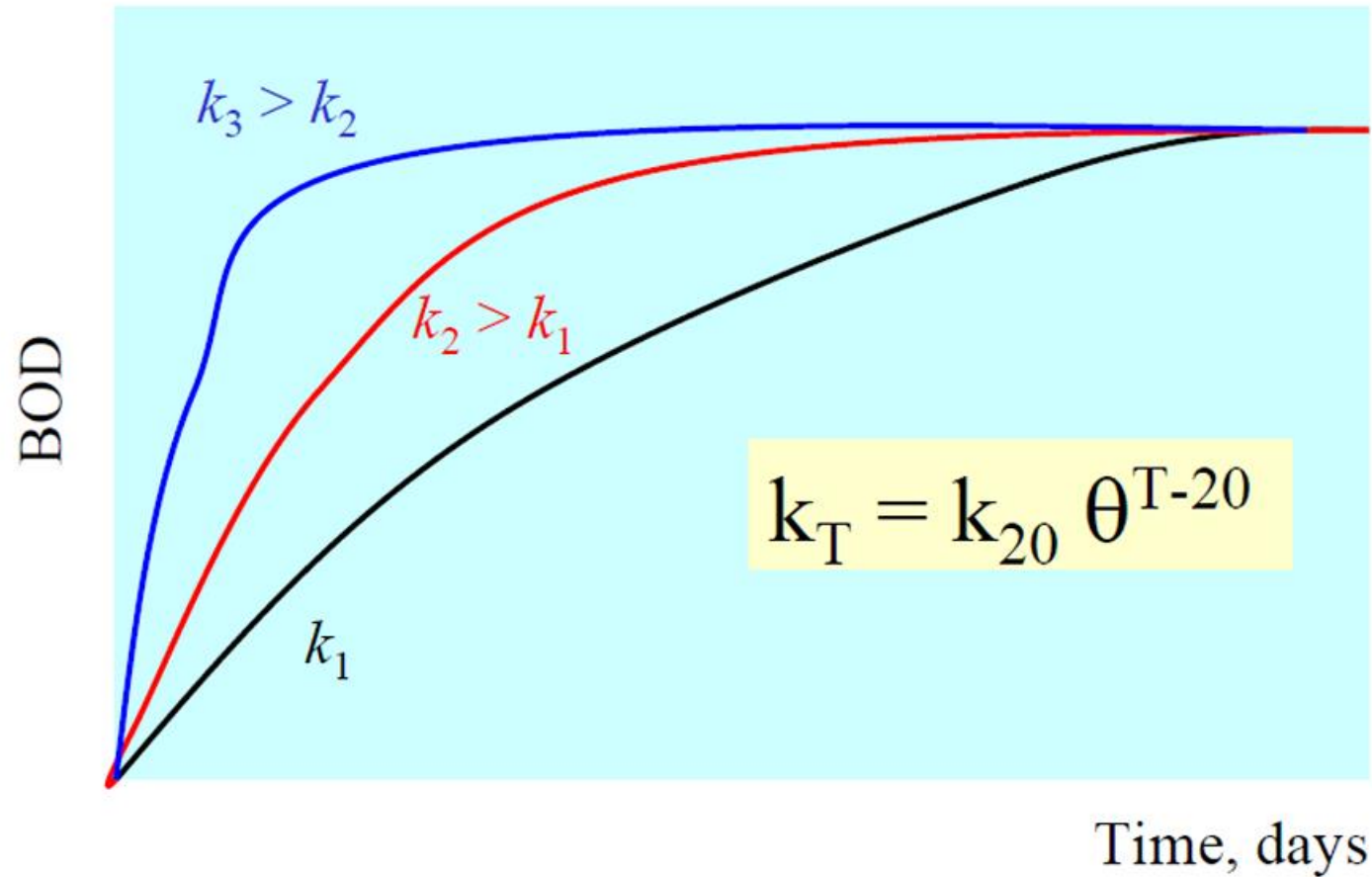

Ultimate BOD

- The “ultimate BOD” is the amount of oxygen required to decompose all of the organic material after “infinite time”. This is usually simply calculated from the 5-day data.
- The total amount of oxygen consumed when the biochemical reaction is allowed to proceed to completion

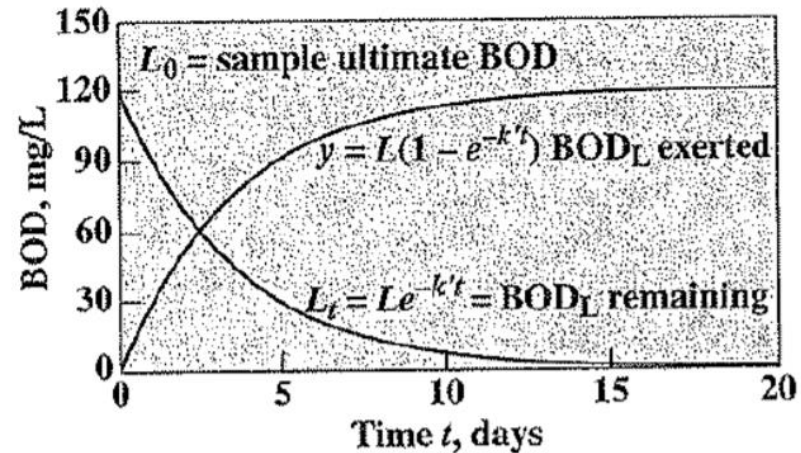

Figure 23.1 Changes in biodegradable organic matter, measured in oxygen equivalents or BOD_L, as a function of time.

Example

A raw wastewater sample from WWTP has 2000 mg/L 5-day BOD (due to carbon only) with reaction constant ($k=0.23/\text{day}$ at 20°C). Calculate ultimate BOD; amounts of BOD exerted on 1- and 15-day and comment on observed differences between 1- and 15-day BOD values.

Problem

A sample of wastewater has an ultimate BOD of 280 mg/L and a 5-day BOD of 240mg/L. Calculate 20-day BOD of this sample.

Answer (279.9 mg/L !!!)

Problem

Determine the 5-day BOD for a 15 ml sample that is diluted with dilution water to a total volume of 300 ml when the initial DO concentration is 8 mg/L and after 5 days, has been reduced to 2 mg/L

Answer (120.0 mg/L !!!)



Wastewater Treatment Engineering
CE 11401455

Biological Treatment

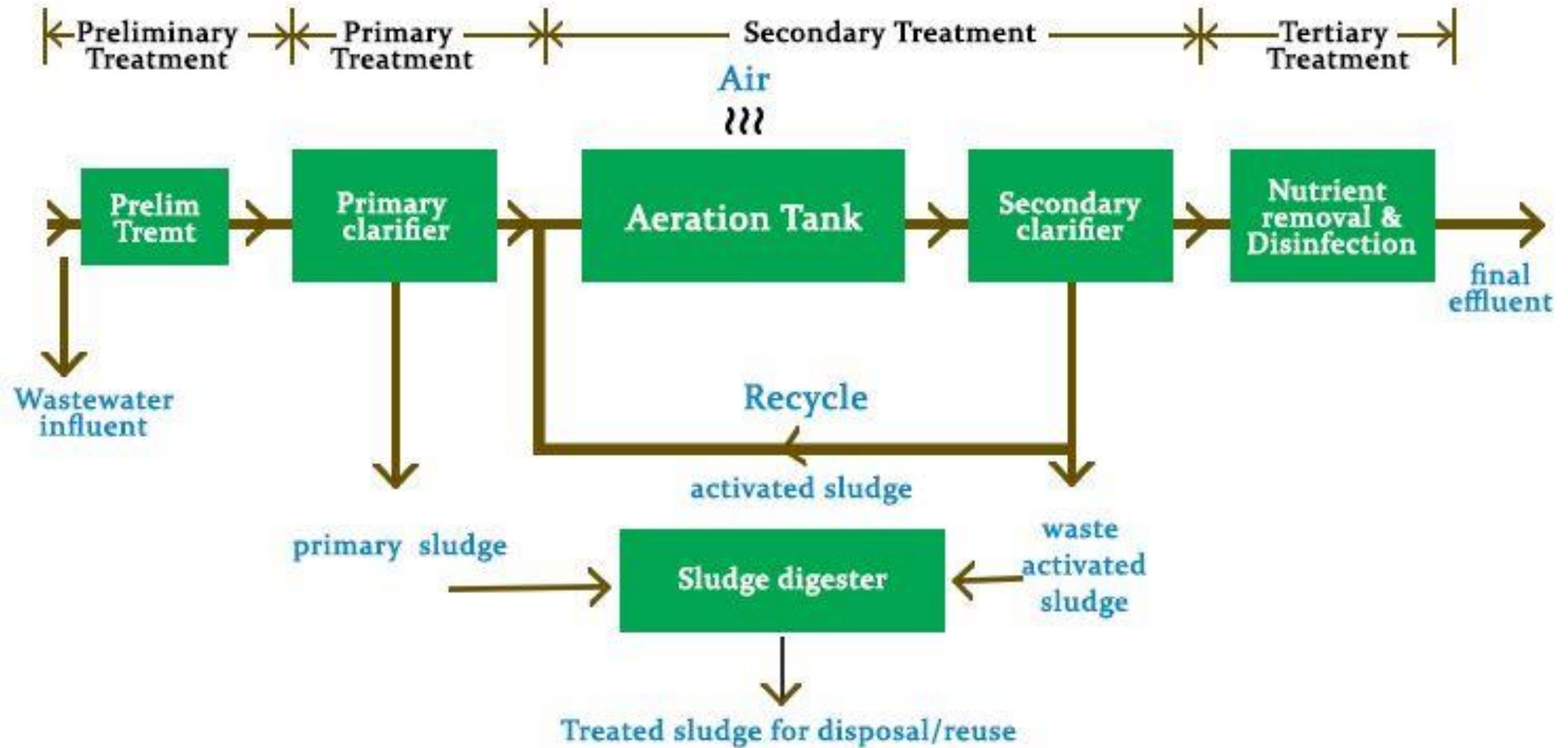

Municipal wastewater treatment systems

- Preliminary treatment (removes materials that can cause operational problems, equalization basins are optional)
- Primary treatment (remove ~60% of solids and ~35% of BOD)
- Secondary treatment (remove ~85% of BOD and solids)
- Advanced treatment (varies: 95+ % of BOD and solids, N, P)
- Final Treatment (disinfection)
- Solids Processing (sludge management)

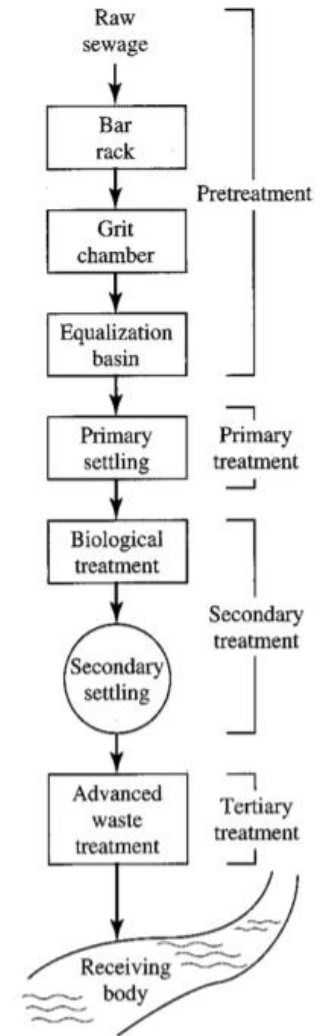

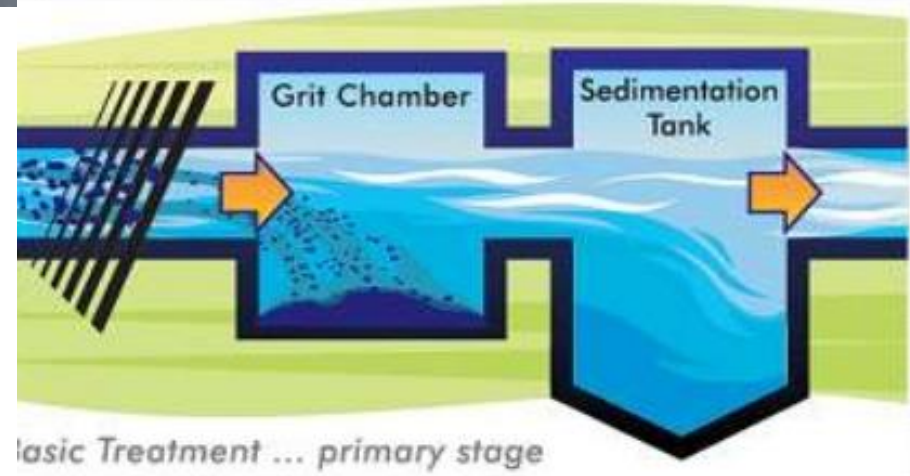
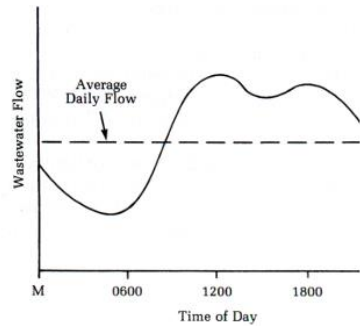

Fig: Horizontal Flow Grit Chamber

Equalization basins



Biological wastewater treatment

Create a very rich environment for growth of a diverse microbial community

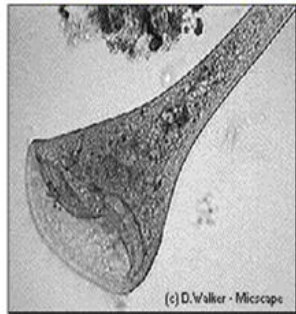
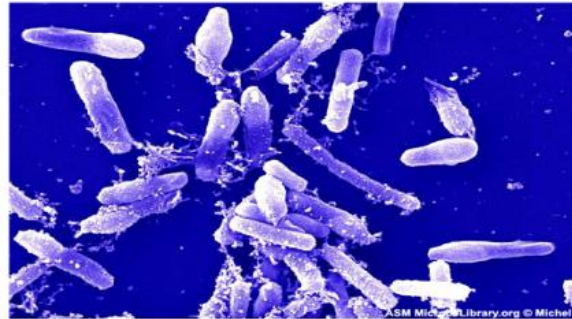
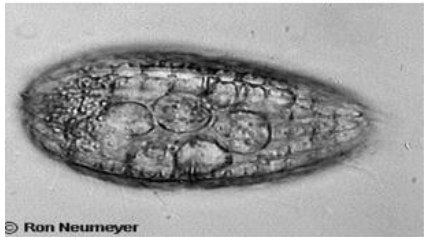

It is a type of waste water treatment in which microorganisms such as bacteria are used to remove pollutants from waste water through bio-chemical reaction.

Classification of biological Waste water methods

Suspended and attached treatment

Suspended growth process is a biological w.w.t in which microorganisms are maintained in suspension while converting organic matter to gases and cell tissue (Activated sludge).

Attached growth is a biological w.w.t in which microorganisms responsible for the conversion of organic matter to gases and cell tissue are attached to some inert material such as rocks, sand, or plastic (Trickling filter).

Aerobic and anaerobic

Aerobic: biological treatment is a process in which the pollutants in the waste water (organic matter) are stabilized by microorganisms in the **presence** of molecular oxygen

Anaerobic: biological treatment is a process in which the pollutants in the waste water (organic matter) are stabilized by microorganisms in the **absence** of molecular oxygen

Objective of biological treatment

- ❑ Reduce the organic content
 - ❑ Reduce the level of nutrients (P, N)
 - ❑ Coagulate suspended solids
 - ❑ Removal of trace organic compounds
 - ❑ In industrial application, also removal of inorganics
-
- ❑ Removal of CBOD, coagulation of nonsettleable colloidal matter, and stabilization of organic matter is accomplished biologically, principally by bacteria

Nutritional growth characteristics

Carbon and energy sources

Classification	Energy Source	Carbon Source
Autotrophic		
Photoautotrophic	light	CO ₂
Chemoautotrophic	Inorganic (oxidation-reduction rxn)	CO ₂
Heterotrophic		
Photoheterotrophic	light	Organic carbon
Chemoheterotrophic	Organic (oxidation-reduction rxn)	Organic carbon

Nutritional growth characteristics

Carbon and energy sources

Autotrophs/lithotrophs

- Able to utilize simple inorganic compounds
 - CO₂ as carbon source, ammonium salts as nitrogen source
- Include phototrophs (photosynthesis) and chemolithotrophs (oxidation of inorganic compounds)

Heterotrophs (bacteria in human body)

- Unable to synthesize own metabolites
- Depend on preformed organic compounds
- Nutritional needs are variable

Cont.

- Inorganic nutrients needed
 - Major: N, P, S, K, Ca, Mg, Fe, Na, Cl
 - Minor: Zn, Mn, Mo, Se, Co, Cu, Ni, V, W
- Organic nutrients needed (“growth factors”) (organism dependent)
 - Amino acids, purines & pyrimidines, vitamins

Main taxonomic ranks

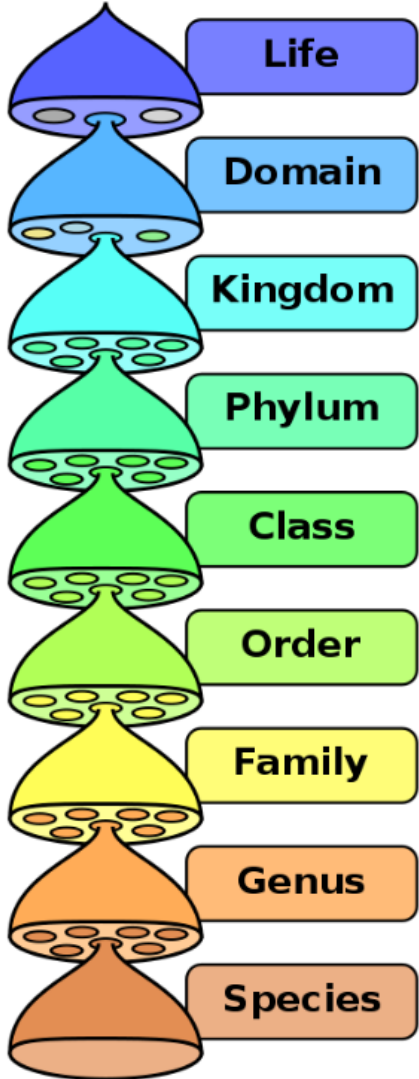

Taxonomy is the arrangement of organisms into related groups based on natural relationships. The most commonly used rank to identify organisms, in order from most general to most specific is Domain, Kingdom, Phyla, Class, Order, Family, Genus, Species.

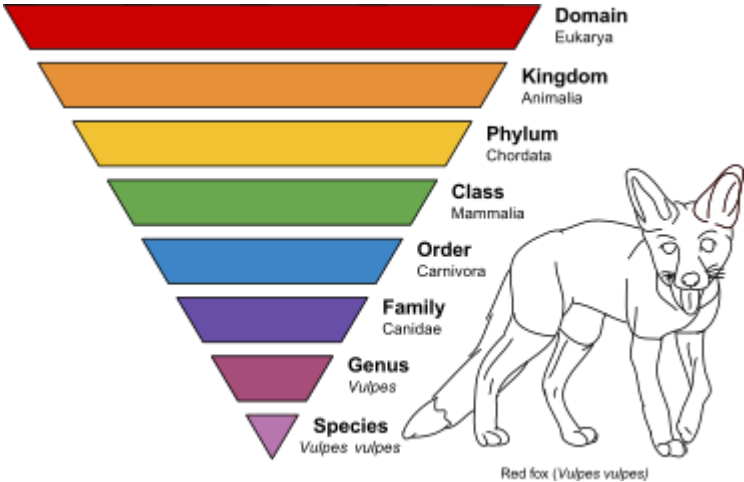
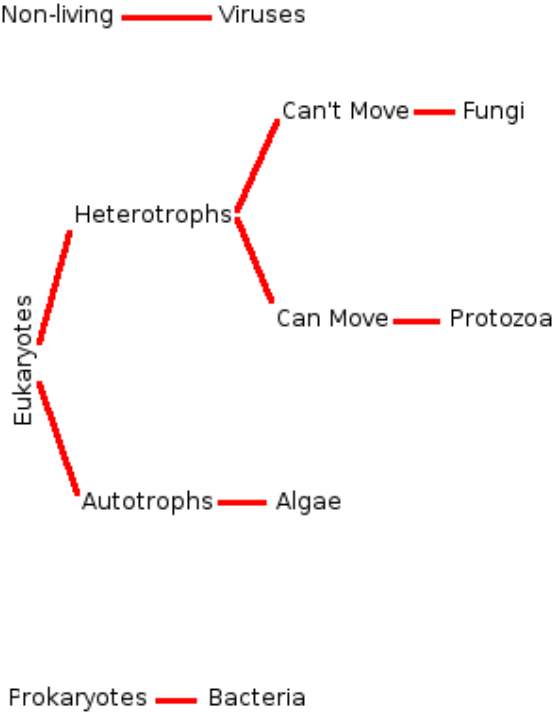

RHESUS MACAQUE (*Macaca mulatta*)

- Kingdom : Animalia
- Phylum : Chordata
- Class : Mammalia
- Order : Primates
- Family : Cercopithecidae
- Genus : *Macaca*
- Species : *M. mulatta*



24
PAIRS

Taxonomic Classifications

Kingdom	Animalia	Animalia	Animalia	Animalia	Animalia
Phylum	Chordata	Chordata	Chordata	Chordata	Chordata
Class	Mammalia	Mammalia	Mammalia	Mammalia	Mammalia
Order	Primates	Primates	Primates	Primates	Primates
Family	Hominidae	Hominidae	Hominidae	Hominidae	Hominidae
Subfamily	Homininae	Homininae	Homininae	Ponginae	Cercopithecidae
Genus	<i>Homo</i>	<i>Gorilla</i>	<i>Pan</i>	<i>Pongo</i>	<i>Papio</i>
Species	<i>sapiens</i>	<i>gorilla</i>	<i>troglydtes</i>	<i>pygmaeus</i>	<i>ursinus</i>

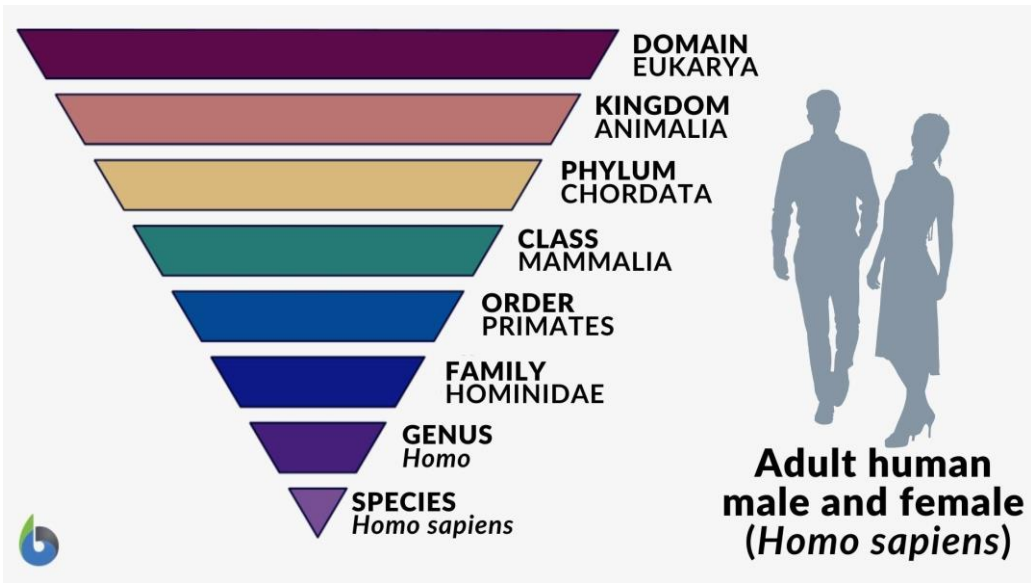

Important microorganisms in wastewater treatment

□ Bacteria

- single-cell prokaryotic
- mainly binary fission reproduction
- spherical (0.5-1.0 μm) or
- cylindrical (0.5-1.0 μm wide / 1.5-3.0 μm long)
- spiral (0.5-5.0 μm wide / 6-15 μm long)
- Unusual shapes
 - Spirochetes
 - Appendaged bacteria
 - Filamentous bacteria

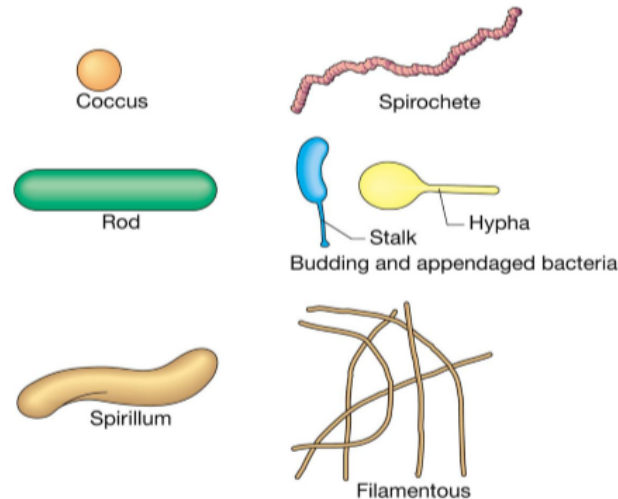

Important microorganisms in wastewater treatment

□ Bacteria

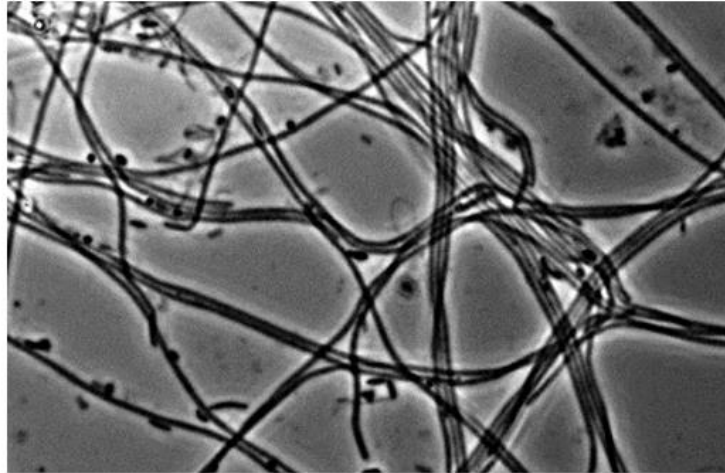
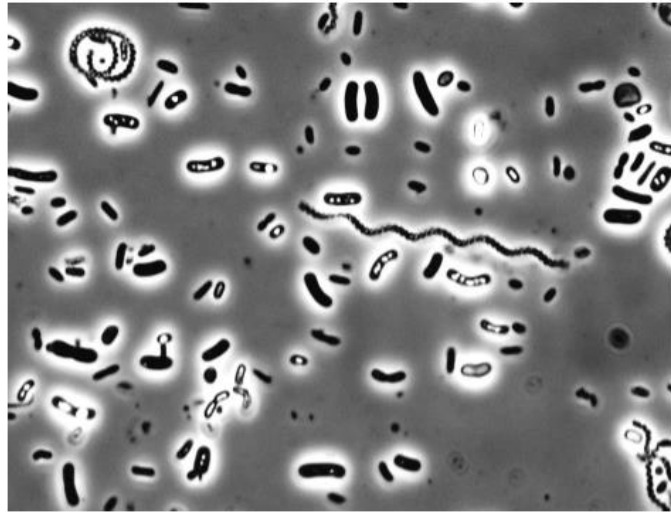

Important microorganisms in wastewater treatment

□ Fungi

- Multicellular, non-photosynthetic, heterotrophic
- Most are strict aerobes
- Able to survive at low pH and nitrogen-limiting conditions
- Can degrade cellulose

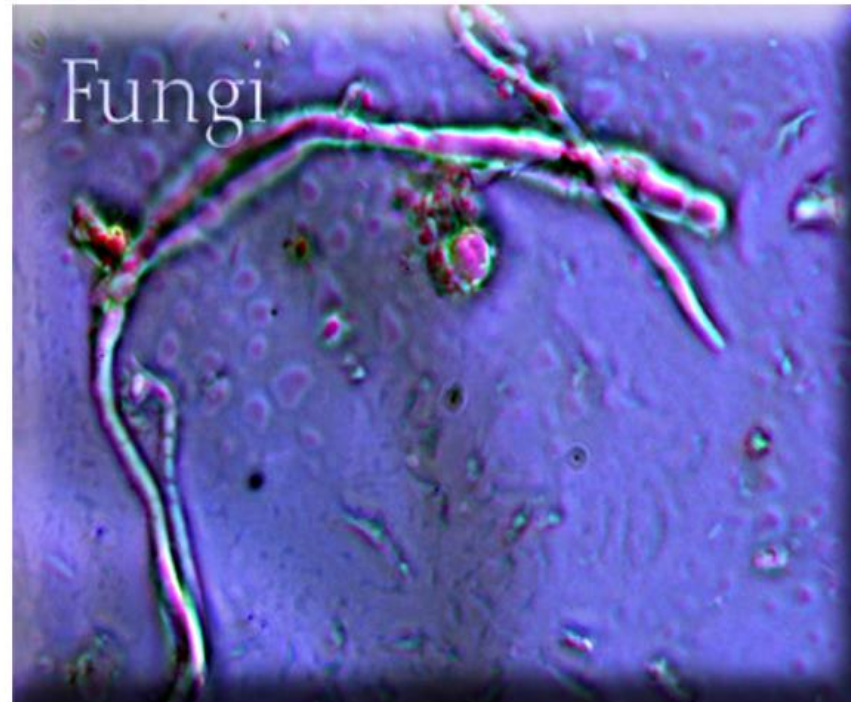

Important microorganisms in wastewater treatment

□ Protozoa

- Motile, microscopic protists, usually single-cell
- Majority are aerobic heterotrophs
- Larger than bacteria / often consume them as energy source
- “Polisher” of effluent



ciliate Metopus

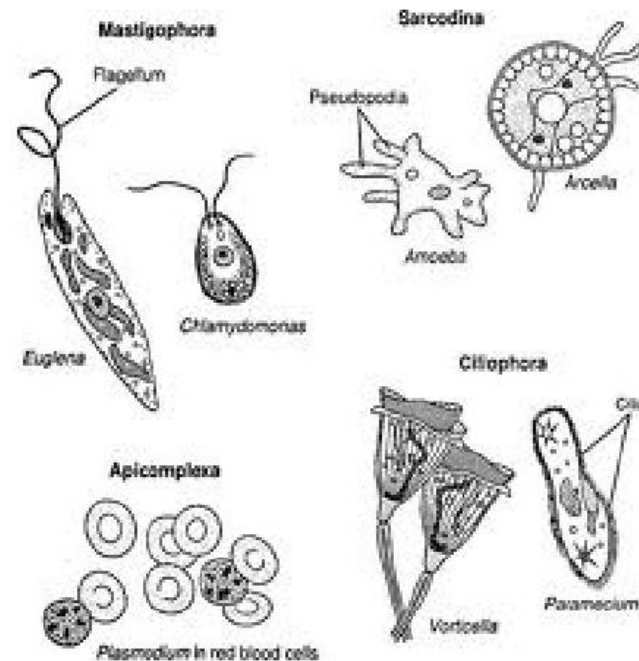

Important microorganisms in wastewater treatment

□ Algae

- Unicellular or multi-cellular, autotrophic, photosynthetic
- Produce oxygen
- Excessive algae growth in receiving waters



Non-living — Viruses

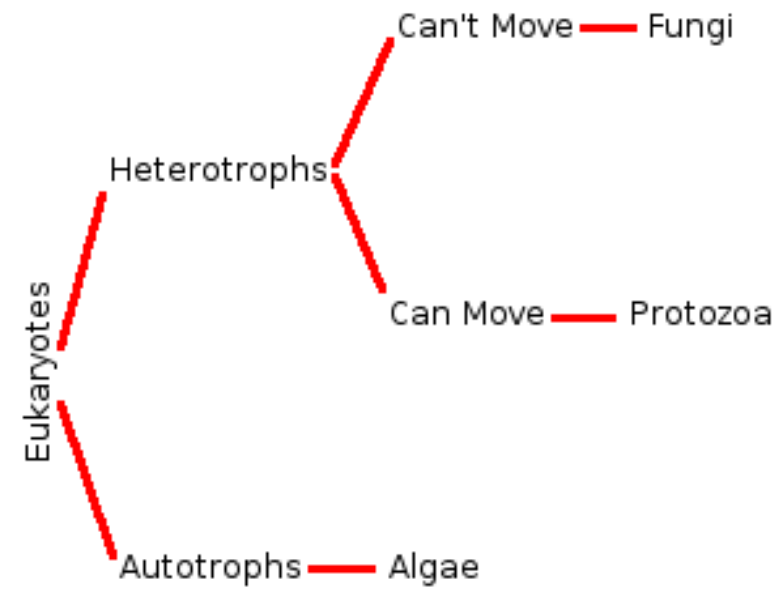

Prokaryotes — Bacteria

Wastewater microbiology video

- <https://www.youtube.com/watch?v=epAh6hHOq3c>



Metabolism

- Metabolism – Sum up all the chemical processes that occur within a cell
- 1. Anabolism: Synthesis of more complex compounds and use of energy
- 2. Catabolism: Break down a substrate and capture energy

Overview of cell metabolism

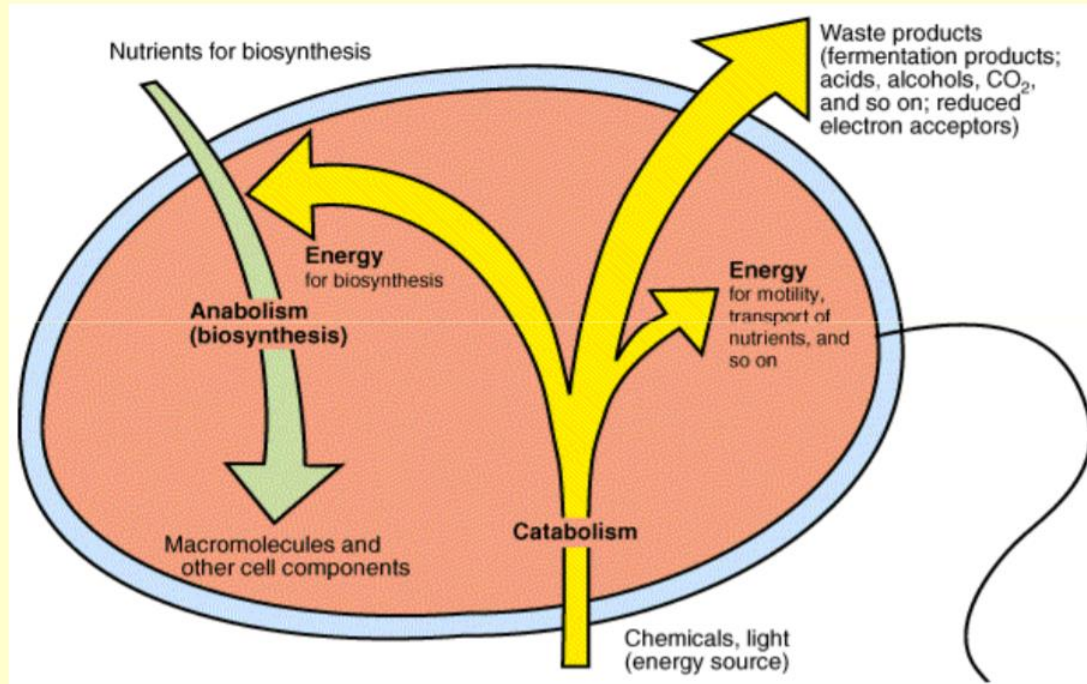

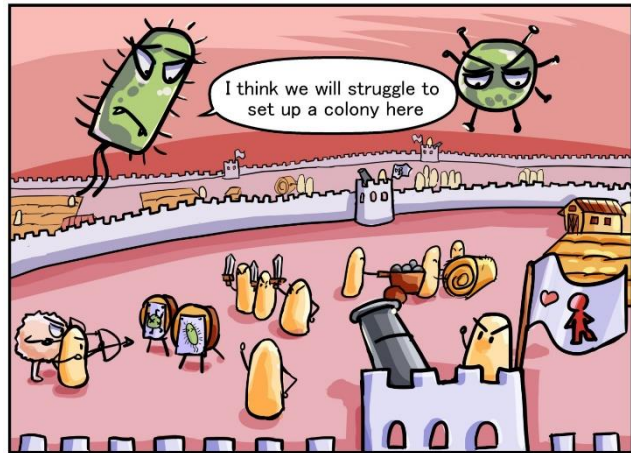

RunawayLabBook.com

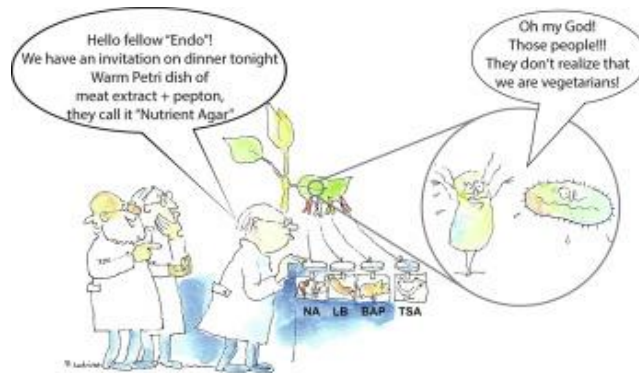

Growth requirements

Physical

- Temperature
- pH
- Osmotic pressure
- Moisture & desiccation

Chemical

- Carbon source
- Nitrogen, sulfur phosphorus
- Oxygen

Temperature

Psychrophiles (cold loving)

- True psychrophiles
(optimum growth at 15 °C)
- Psychrotrophs

(optimum growth at 20-30 °C)

Mesophiles (moderate temperature loving)

Thermophiles (heat loving)

Hyperthermophiles (tolerate extreme temperatures)

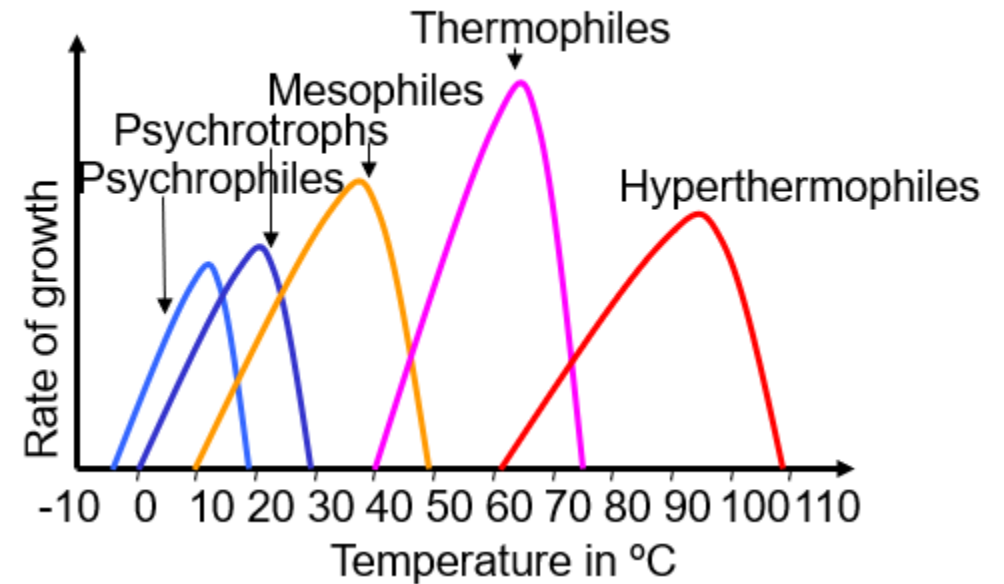

Most pathogenic bacteria are mesophiles
And grow optimally at 37 °C
(human body temperature)

Temperature

- **Minimum Temperature:** Temperature below which growth ceases, or lowest temperature at which microbes will grow.
- **Optimum Temperature:** Temperature at which its growth rate is the fastest.
- **Maximum Temperature:** Temperature above which growth ceases, or highest temperature at which microbes will grow.

pH

- Most medically important bacteria grow at neutral or slightly alkaline pH (7.2 to 7.6)
- Very few bacteria grow below pH 4
- Lactobacilli grow in acidic pH; cholera *vibrio* grow in alkaline pH
- Growth media includes chemical buffers to prevent acid production
- Foods are preserved by acids produced by bacterial fermentation

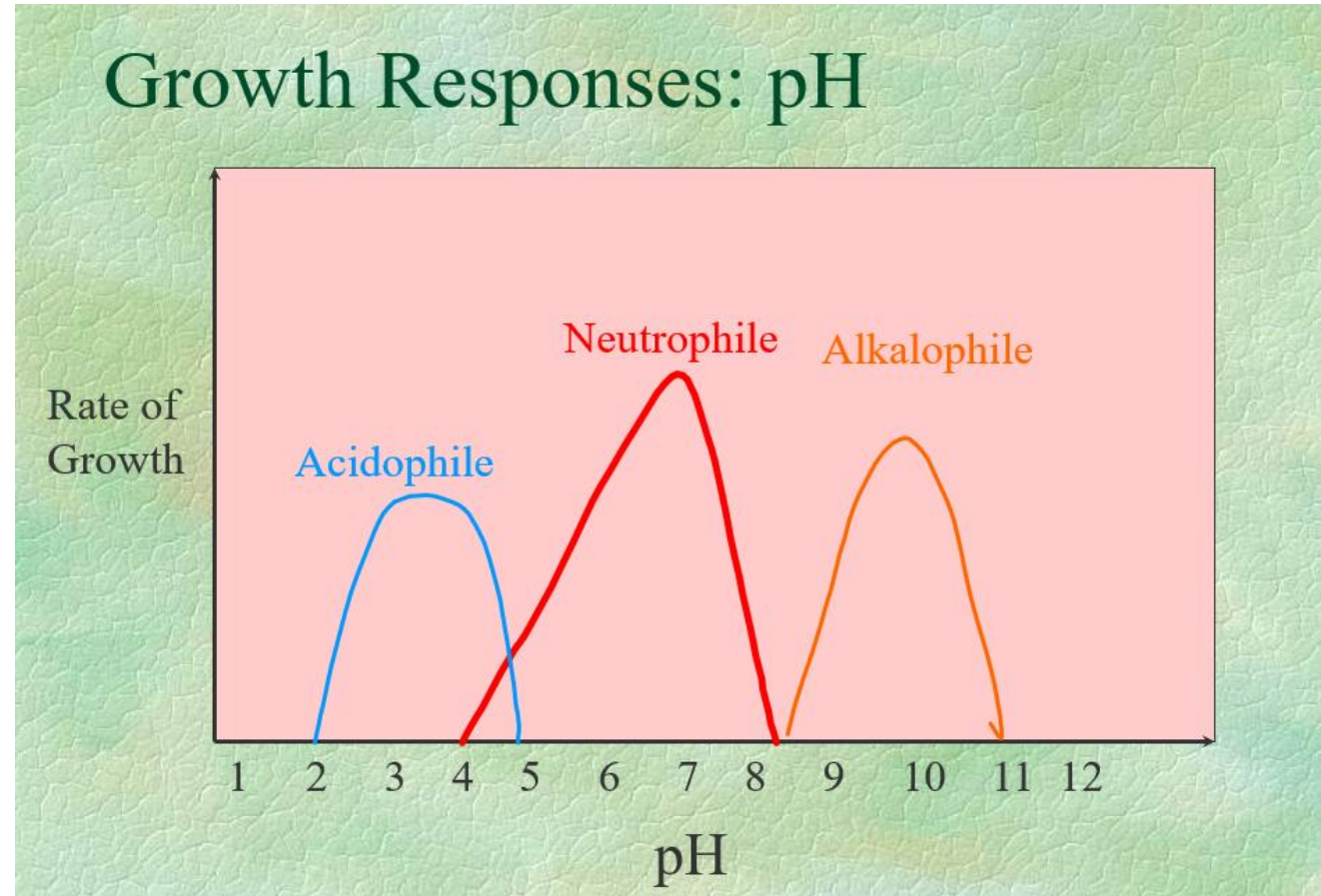

pH

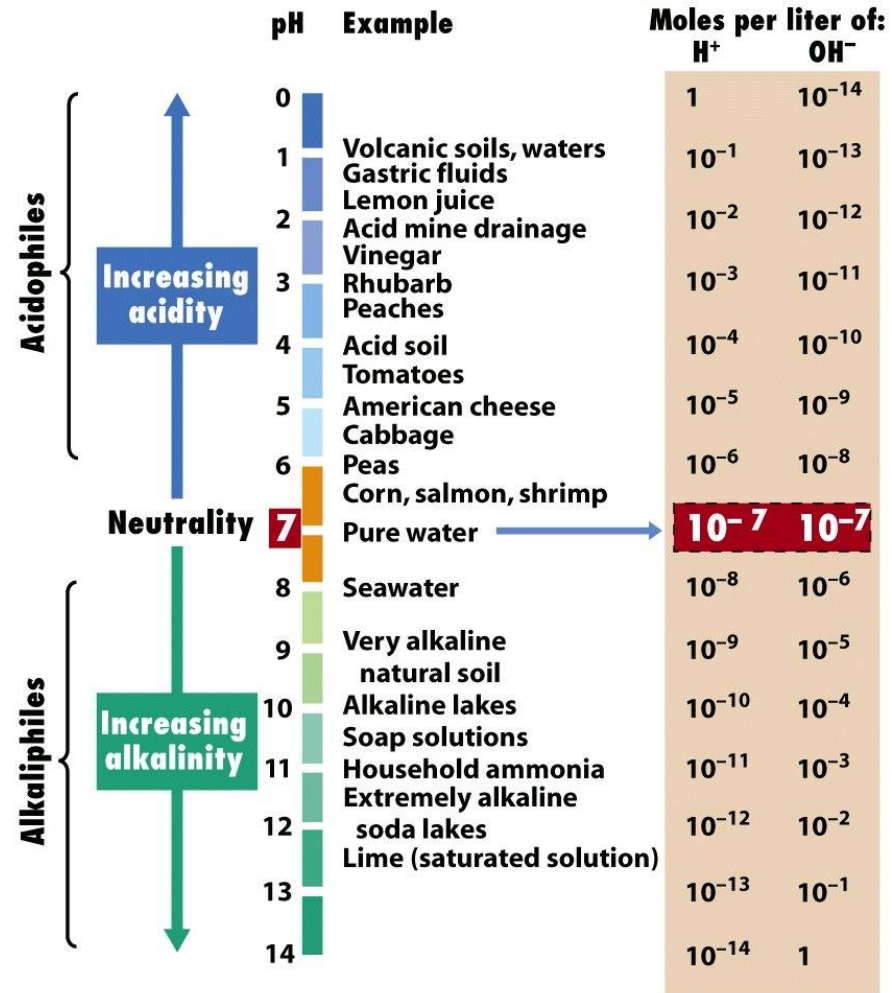

Figure 6-22 Brock Biology of Microorganisms 11/e
© 2006 Pearson Prentice Hall, Inc.

Oxygen

Obligate aerobes

- Only aerobic growth, oxygen required

Facultative anaerobes (most human pathogens)

- Greater growth in presence of oxygen

Obligate anaerobes

- Only anaerobic growth, cease with oxygen

Aerotolerant anaerobes (e.g., *C. perfringens*)

- Only anaerobic growth, continues with oxygen

Microaerophiles (e.g., *M. tuberculosis*)

- Only aerobic growth with little oxygen

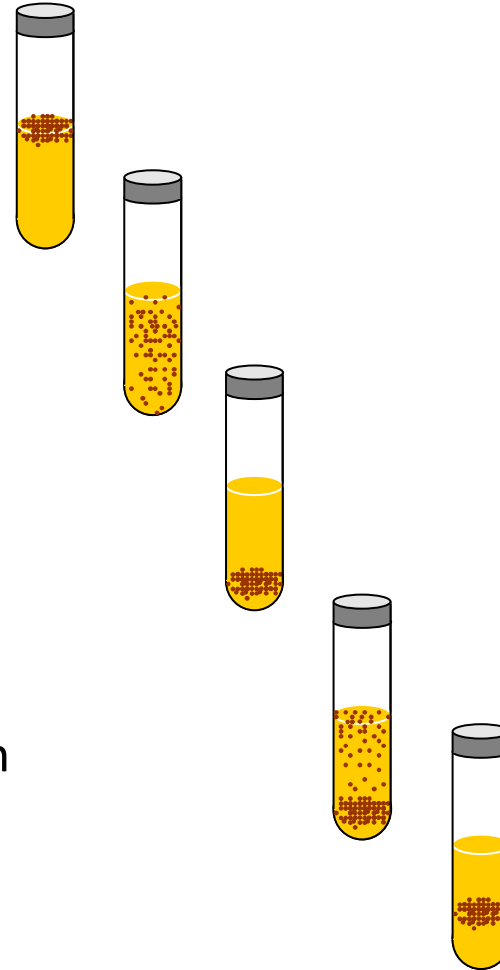

Microbial growth

- Microbial Growth refers to an increase in cell number, not in cell size.
- Bacteria grow and divide by binary fission, a rapid and relatively simple process.

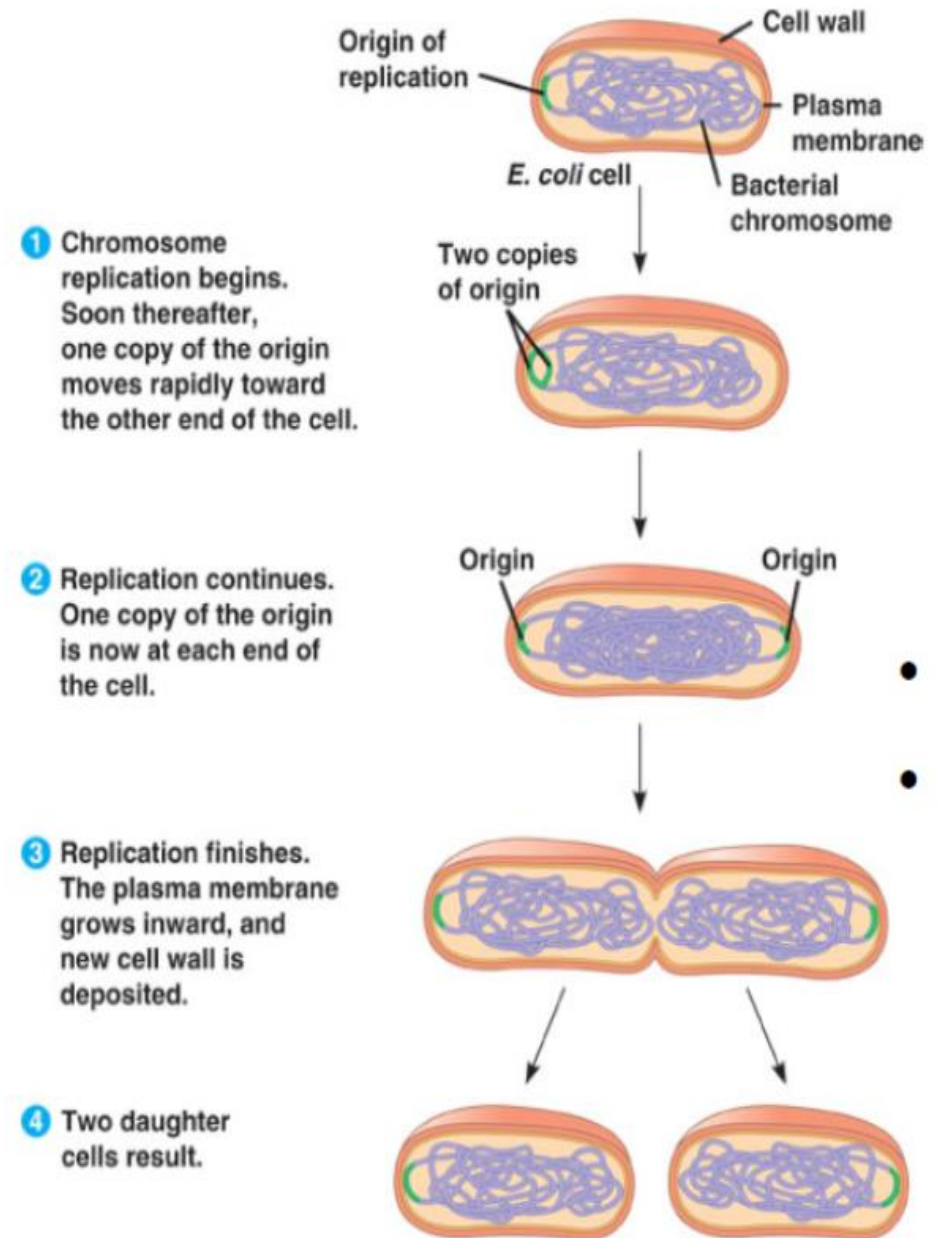

Bacterial growth in pure culture

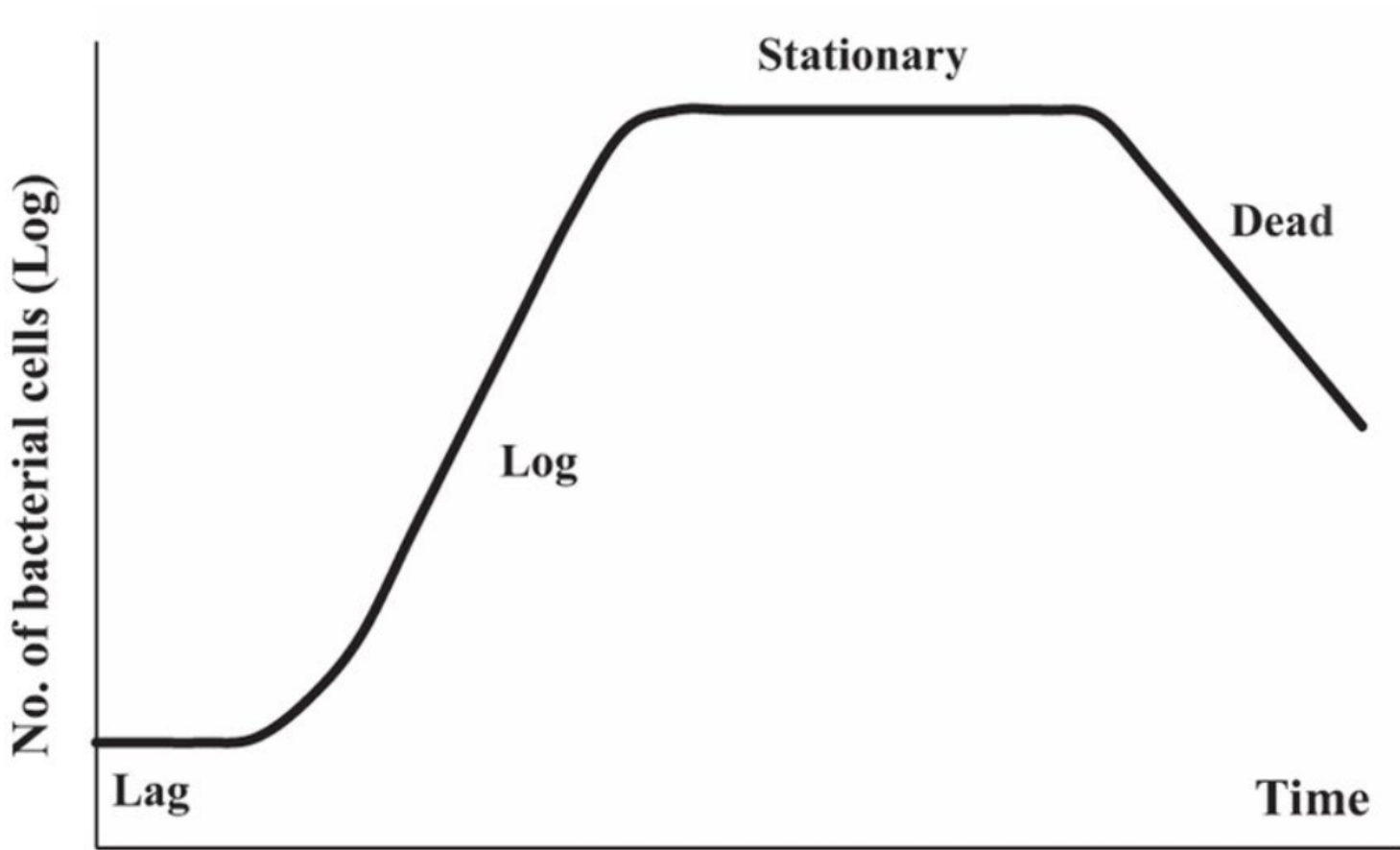

	Bacterial number	Bacterial mass
Lag Phase	Acclimation to new environment, begin to divide	Mass begins to increase before cell division
Log-growth Phase	Cell division at rate determined by generation time and ability to process food	Always excess food, rate of growth is function of ability to process substrate
Stationary Phase	Cell exhausted substrate/nutrients needed for growth or growth offset by death	Declining growth phase: limitation of food supply
Log-death Phase	Death rate > production rate, function of viability and environment	Endogenous Phase: limitation of food supply, MO metabolize own protoplasm, lysis

Measurement of cell growth

Measure total counts

- Measure both viable and non-viable bacterial cells
- Direct microscopy using Gram stain; automated cell counter

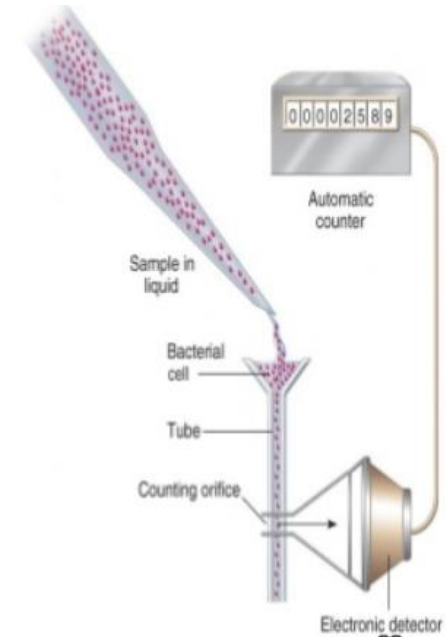

Electronic counter

Measure viable counts

- Measure only viable cells
- Pour plate cultures to give quantitative number of viable bacteria

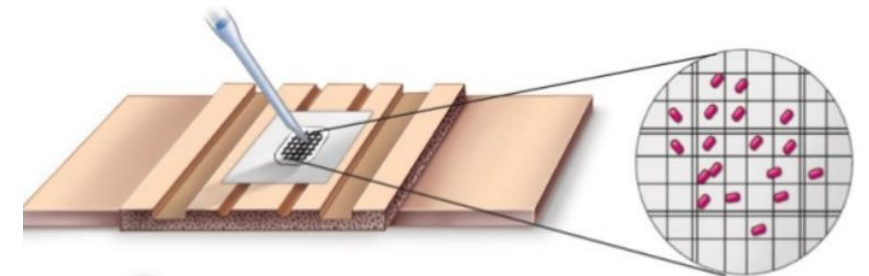

Counting chambers

Activated sludge

- Wastewater is aerated in a tank (Aeration tank).
- Bacteria are encouraged to grow by providing
 - Oxygen
 - Food (BOD)
 - Nutrients
 - Correct temperature
 - Time
- As bacteria consume BOD, they grow and multiply.
- Treated wastewater flows into secondary clarifier.
- Bacterial cells settle, removed from clarifier as sludge
- Part of sludge is recycled back to activated sludge tank, to maintain bacteria population (Return Activated Sludge (RAS)).
- Remainder of sludge is wasted (Waste Activated Sludge - WAS).

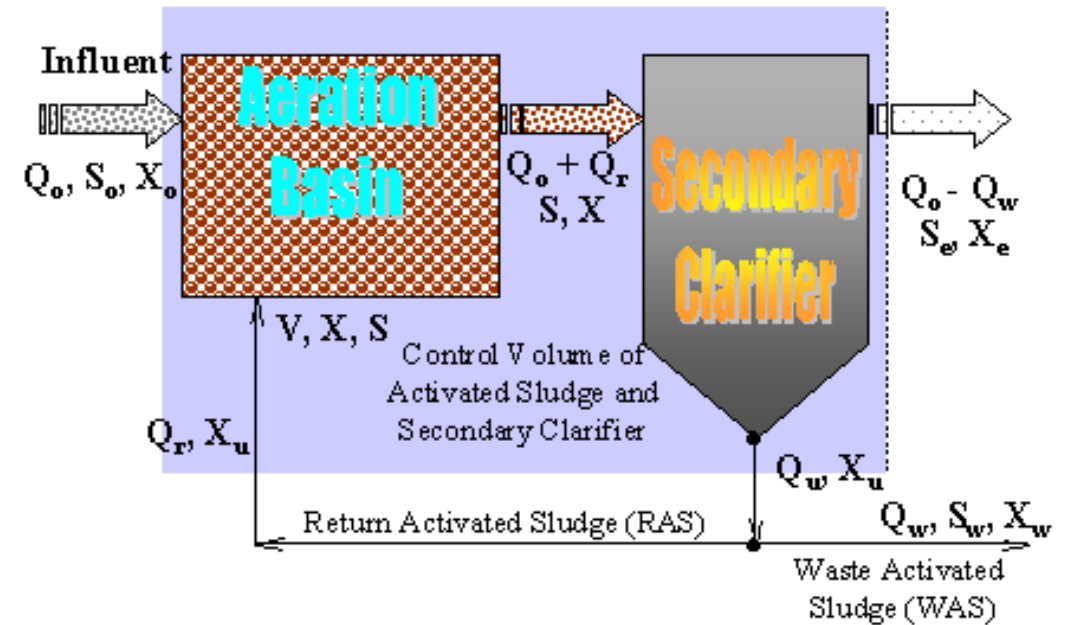

Activated Sludge process

Activated Sludge Process

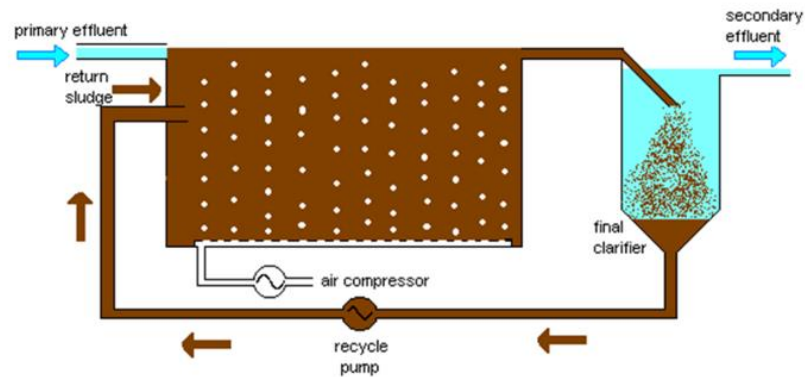

<http://www.geocities.com/RainForest/5161/wwtps.htm>

- Process in which a mixture of wastewater and microorganisms is agitated and aerated
- Leads to oxidation of dissolved organics
- After oxidation, separate sludge (mostly microbial cells, water, and other contaminants) from wastewater
- Induce microbial growth
 - Need food, oxygen
 - Want **Mixed Liquor Suspended Solids (MLSS)** of 3,000 to 6,000 mg/L

Activated Sludge Process

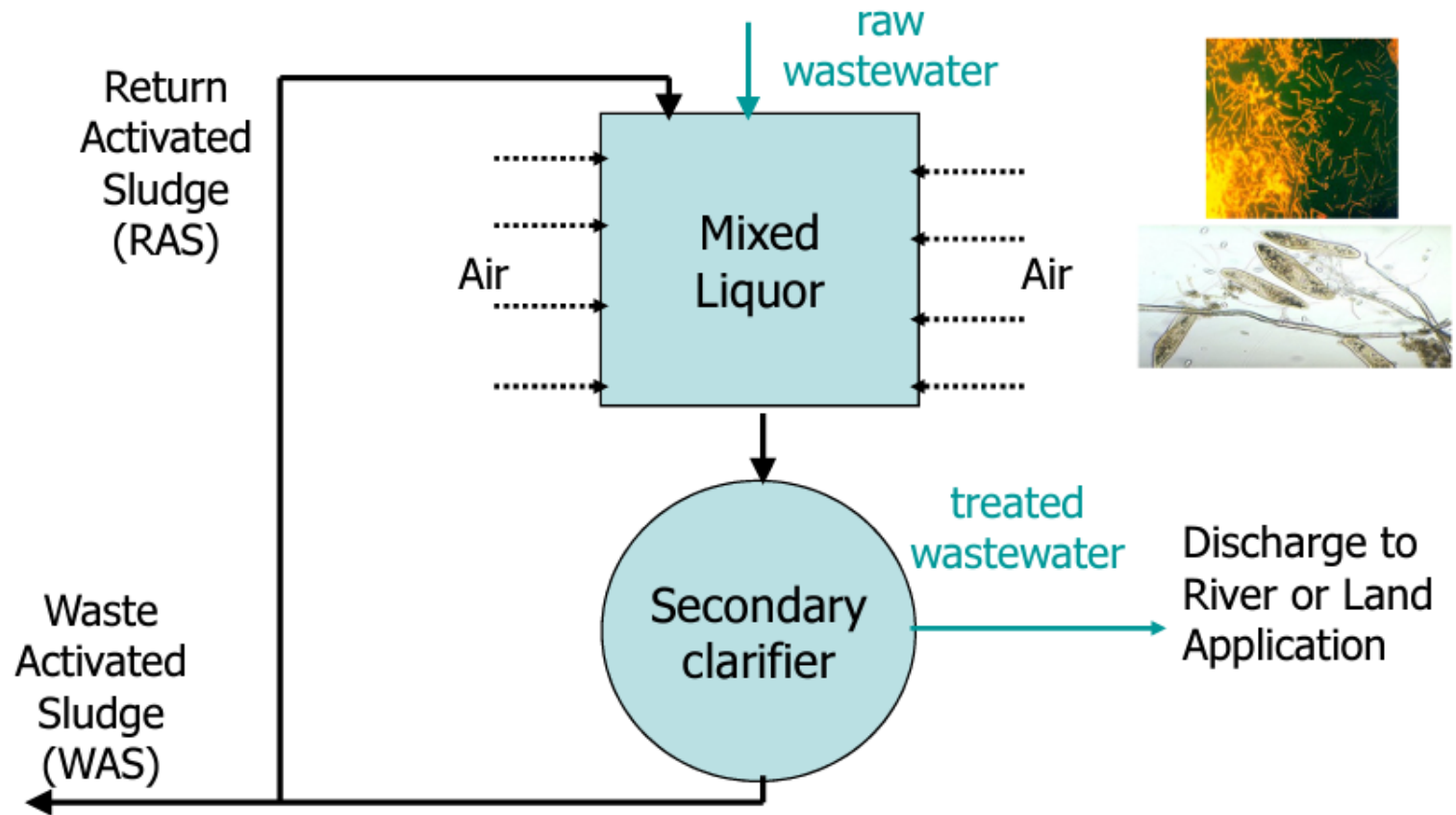

Aeration tank

- Oxygen is introduced into the system

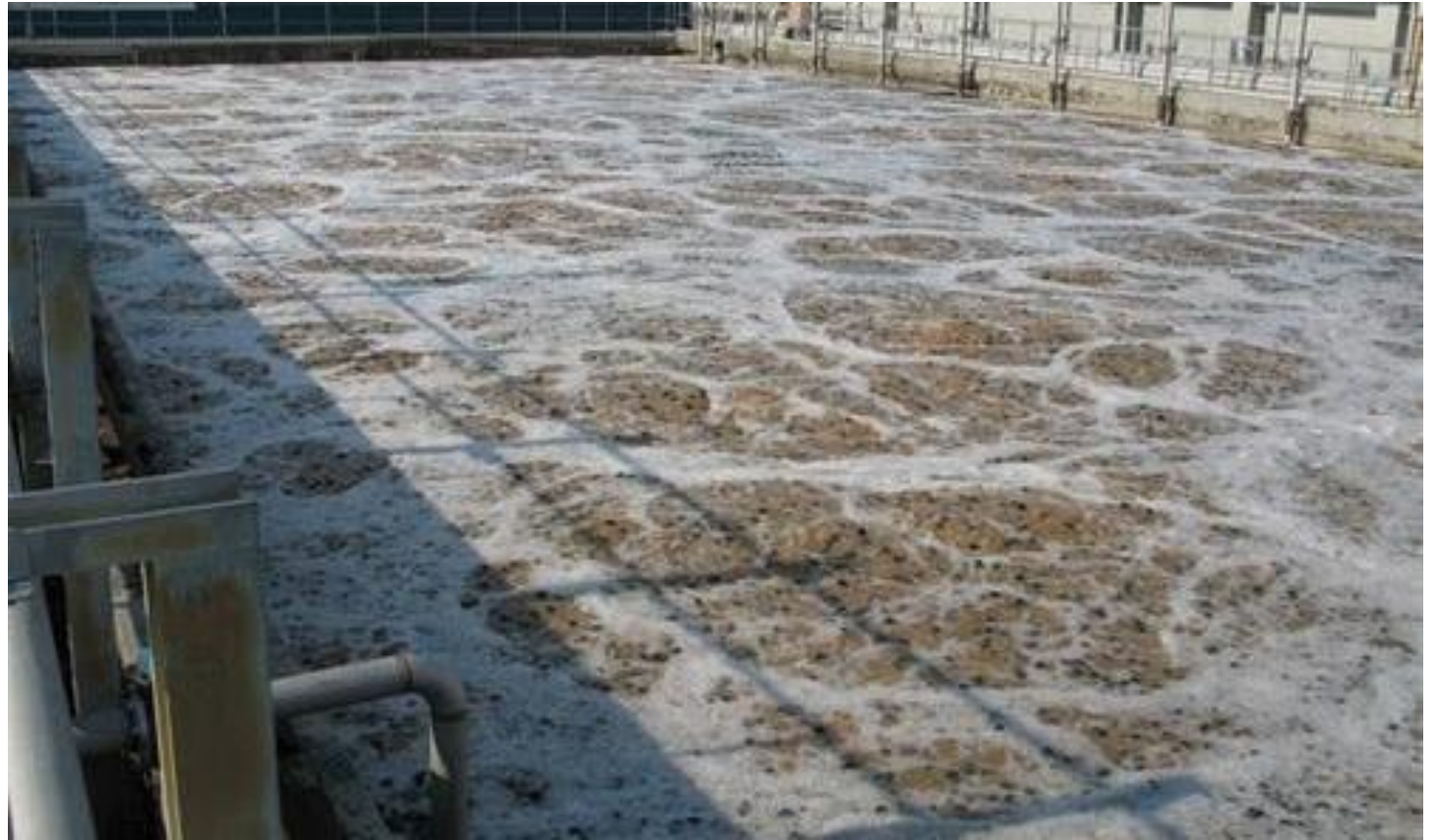

Aeration tank- aeration source

- Ensure that adequate oxygen is fed into the tank
- Provided pure oxygen or compressed air



Cryogenic air separation facility, Hyperion, Playa del Rey, (CA)

Aeration tank- Surface aerators



Aeration tank_Role of microorganisms

- Microorganisms consume organic matter from the wastewater, using oxygen for respiration.

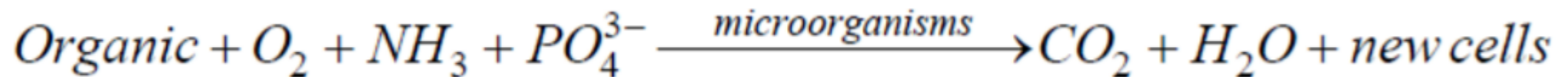
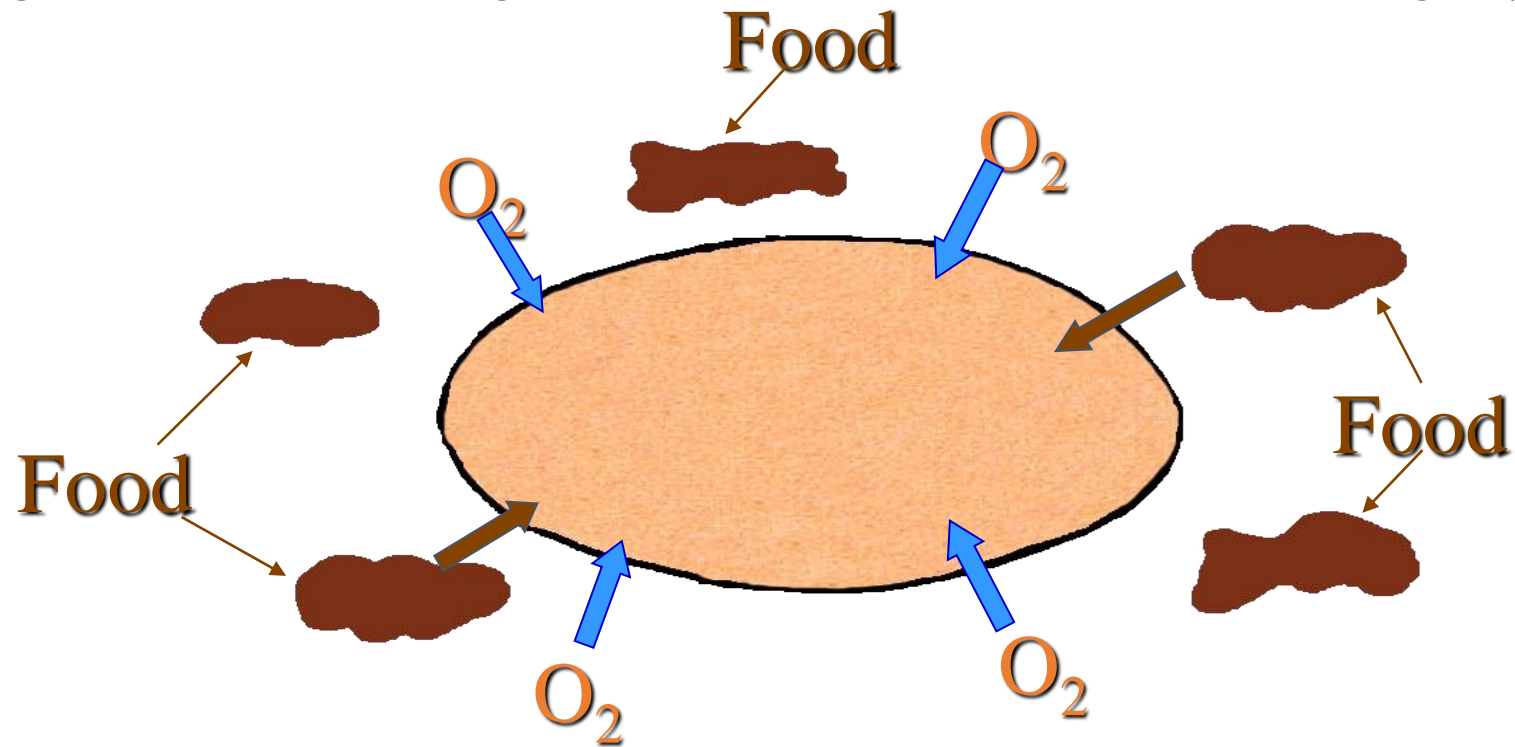

Removal mechanism

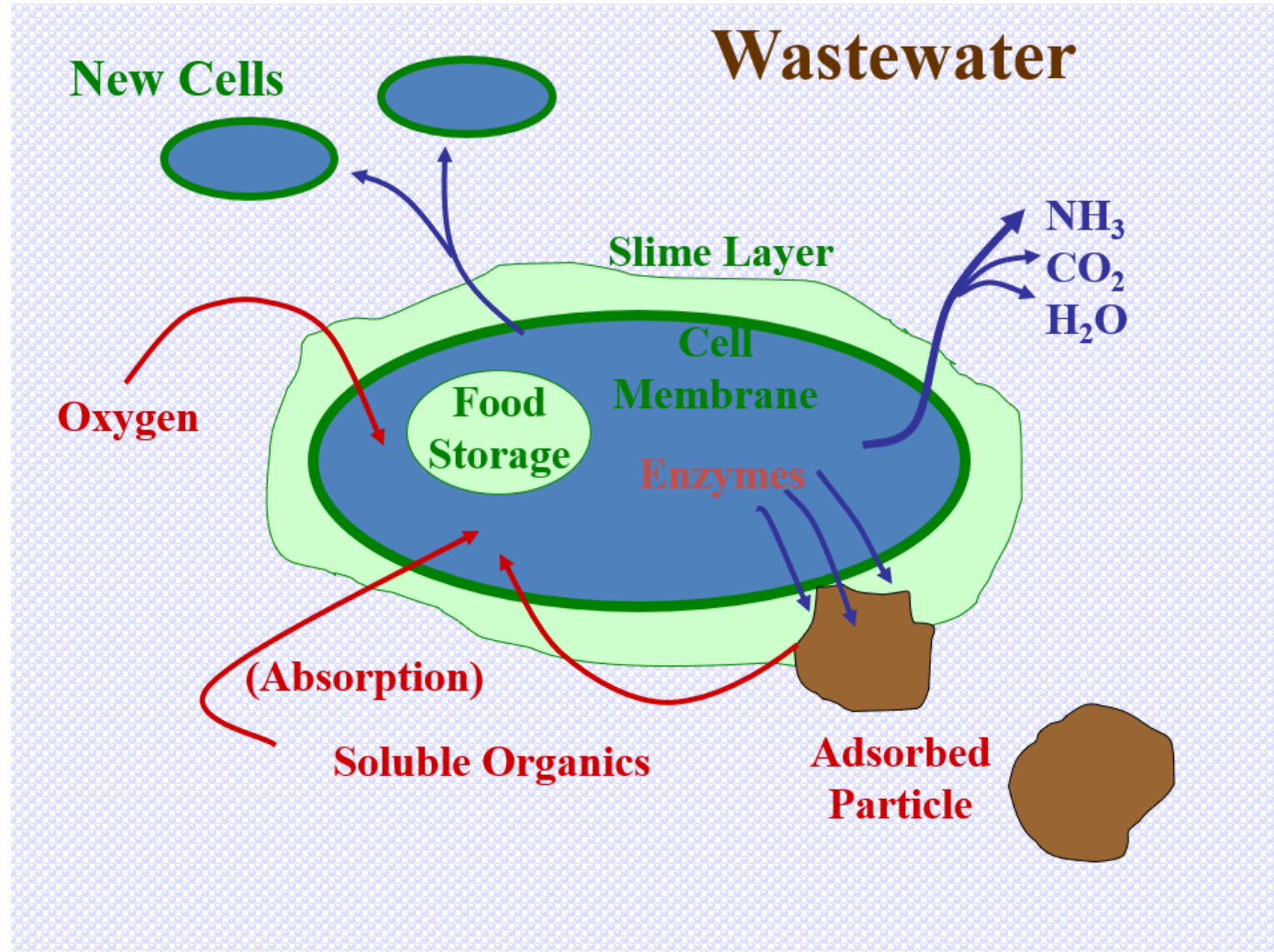

Removal Mechanism

- ❑ Suspended organic matter entering the reactor
- ❑ Rapidly adsorbed by activated sludge (20-45 minutes)
- ❑ Adsorbed organic solids solubilized and oxidized
- ❑ Soluble organics sorbed (both adsorbed and absorbed) at high rate at upstream end
- ❑ Sorption decreases as mixed liquor flows downstream
- ❑ Aeration supplies oxygen and mix for adequate contact
- ❑ End products: NH_4^+ , NO_2^- , NO_3^- , PO_4^{3-}

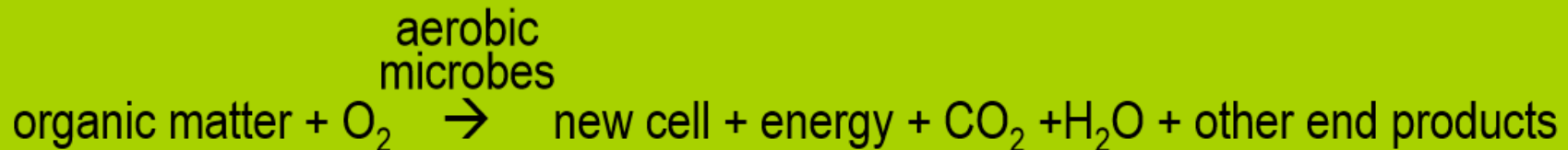

Activated sludge system

- It is aerobic suspended growth biological wastewater treatment method in which dissolved organic and inorganic matter can be removed. Some of the suspended and colloidal matter can also be removed indirectly by sticking to the slime bacteria.
- This treatment is achieved in tanks called aeration tanks. Oxygen is supplied to these tanks to allow aerobic biochemical reaction to occur.
- In the aeration tank, the microorganisms feed on dissolved solids mainly organic matter and produce large amounts of bacteria (colonies). This means that microorganisms convert dissolved solids into suspended solids (the bacterial colonies).
- After the aeration tank, a secondary sedimentation tank is installed to separate the bacteria from liquid
- The separated bacteria is called activated sludge. Part of the sludge is wasted and the remaining part is returned back (Recycle) to the aeration tank. The recycle of the sludge to aeration tank is very important to keep a specific concentration of the bacteria in the system to perform wastewater treatment.
- The mixture of wastewater with bacteria in the aeration tank is called mixed liquor suspended solids (MLSS)

Activated sludge System

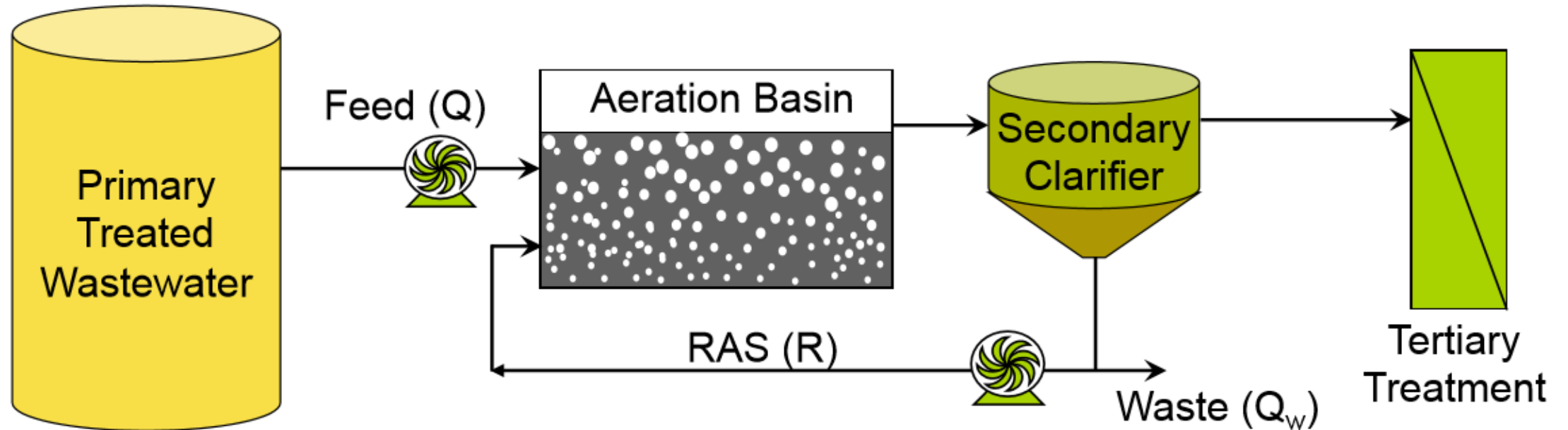

Activated sludge process terminology

- ❑ Mixed liquor = activated sludge + wastewater mixture (aeration tank contents)
- ❑ Mixed liquor suspended solids (MLSS)
- ❑ Mixed liquor volatile suspended solids (MLVSS)
 - \approx organic fraction of SS \approx bacteria concentration
 - MLVSS = 80-90% MLSS

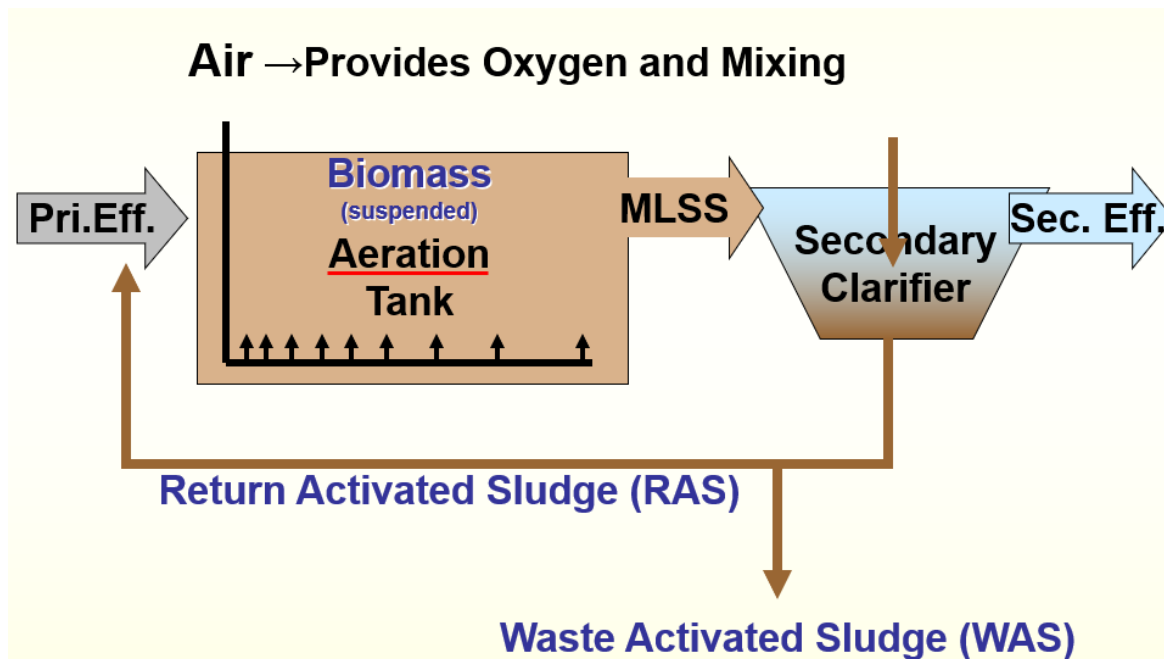

Cell yield

- ❑ Bacteria derive more energy from aerobic processes
→ more biomass
- ❑ Can be measured experimentally or theoretically

$$\text{Cell Yield} = Y = \frac{\text{mass of biomass}}{\text{mass of substrate consumed}}$$

- Experimentally, measure mass of biomass (usually as VSS) and mass of substrate
- Theoretically, use stoichiometry/energetics, balanced reactions

F/M ratio

Need to balance organic load (lbs/grams BOD) with number of active organisms in treatment system

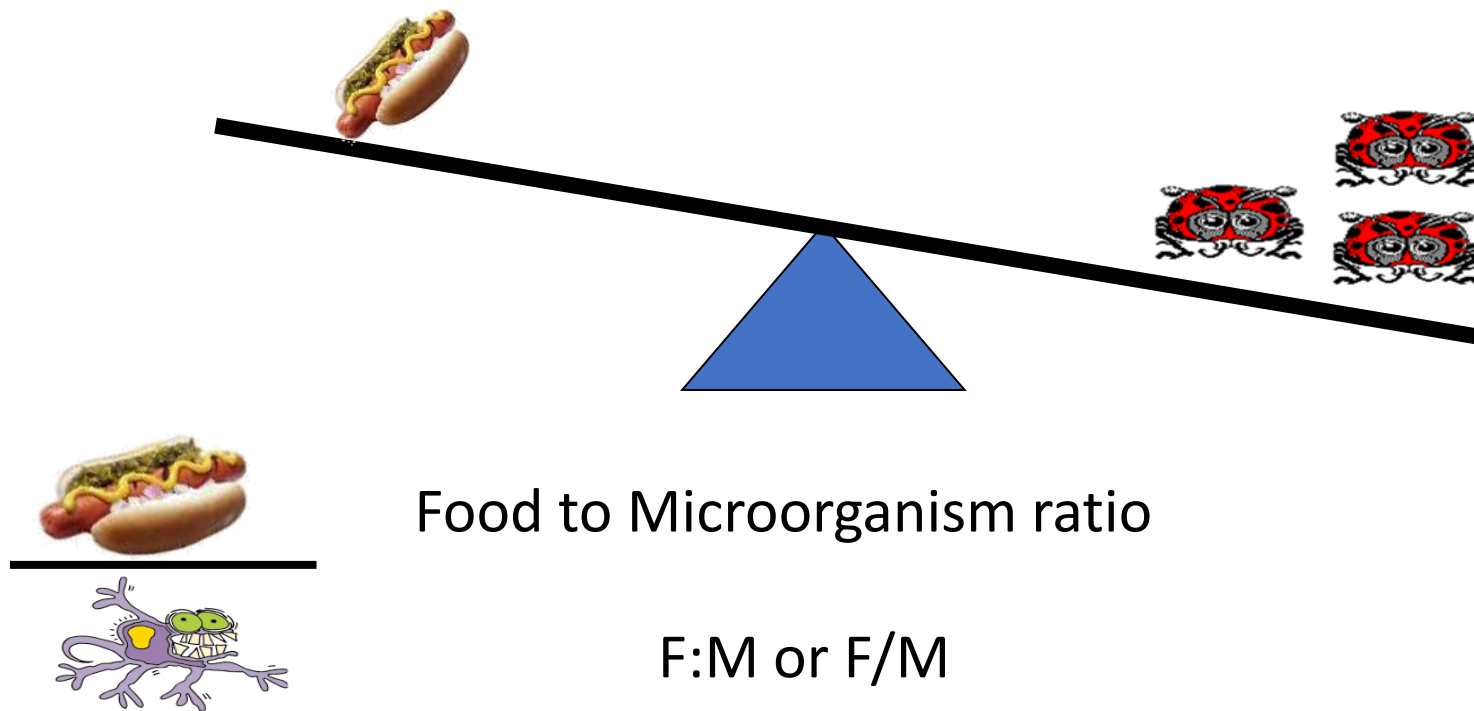

F/M

- How is **M** (Microorganisms) measured?
- Mixed Liquor Volatile Suspended Solids (MLVSS)

M = Pounds MLVSS

The F/M Ratio for Best Treatment Will Vary for Different Facilities

Determined by Regular Monitoring and
Comparing to Effluent Quality

Often Will Vary Seasonally

F/M

$$\frac{\text{Hot Dog}}{\text{Microorganism}} = \frac{\text{Lbs of BOD}}{\text{Lbs. of MLVSS}}$$

Typical Range:

Conventional Activated Sludge

F:M 0.25 - 0.45

Extended Aeration Activated Sludge

F:M 0.05 - 0.15

F/M

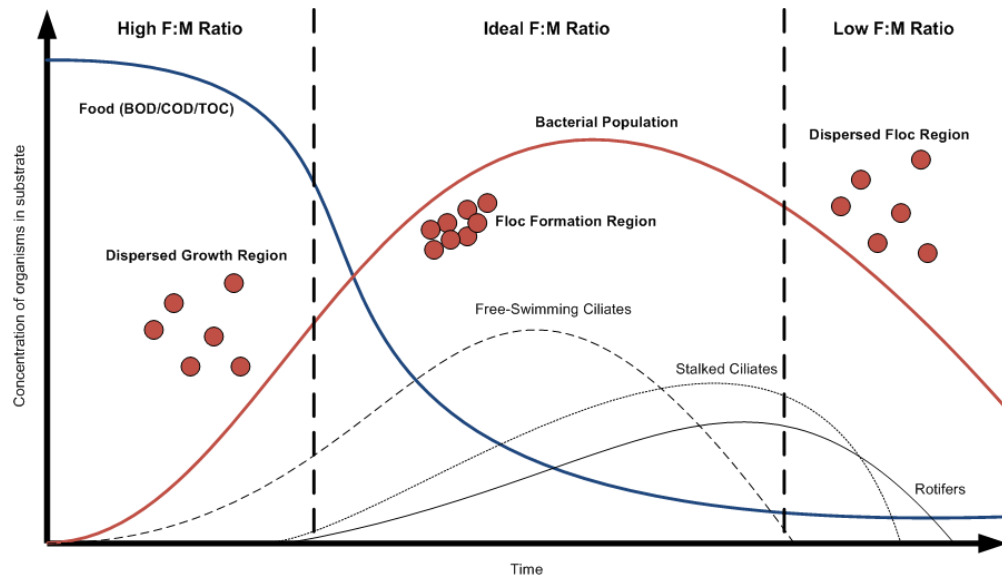

- **Low F/M (low rate of wasting)**
 - starved organisms
 - more complete degradation
 - larger, more costly aeration tanks
 - more O₂ required
 - higher power costs (to supply O₂)
 - less sludge to handle
- **High F/M (high rate of wasting)**
 - organisms are saturated with food
 - low treatment efficiency

Cell Residence Time (CRT)

The average length of time in days that an organism remains in the secondary treatment system

Cell Residence Time, CRT

$$\text{CRT, days} = \frac{\text{Total MLVSS, lbs}}{\text{Total MLVSS Wasted, lbs/d}}$$

Example:

MLVSS = 6681 lbs

MLVSS Wasted = 835 lbs/d

Calculate the CRT.

$$\text{CRT} = \frac{6681 \text{ lbs}}{835 \text{ lbs/d}}$$

$$\text{CRT} = 8.0 \text{ Days}$$

Conventional Activated Sludge

Aerator Detention Time

F:M 0.25 - 0.45

CRT 4 - 6 Days

Extended Aeration Activated Sludge

Aerator Detention Time

F:M 0.05 - 0.15

CRT 15 - 25 Days

Organic load

**Organic Load = Pounds of Organics (BOD)
Coming into Aeration Tank**

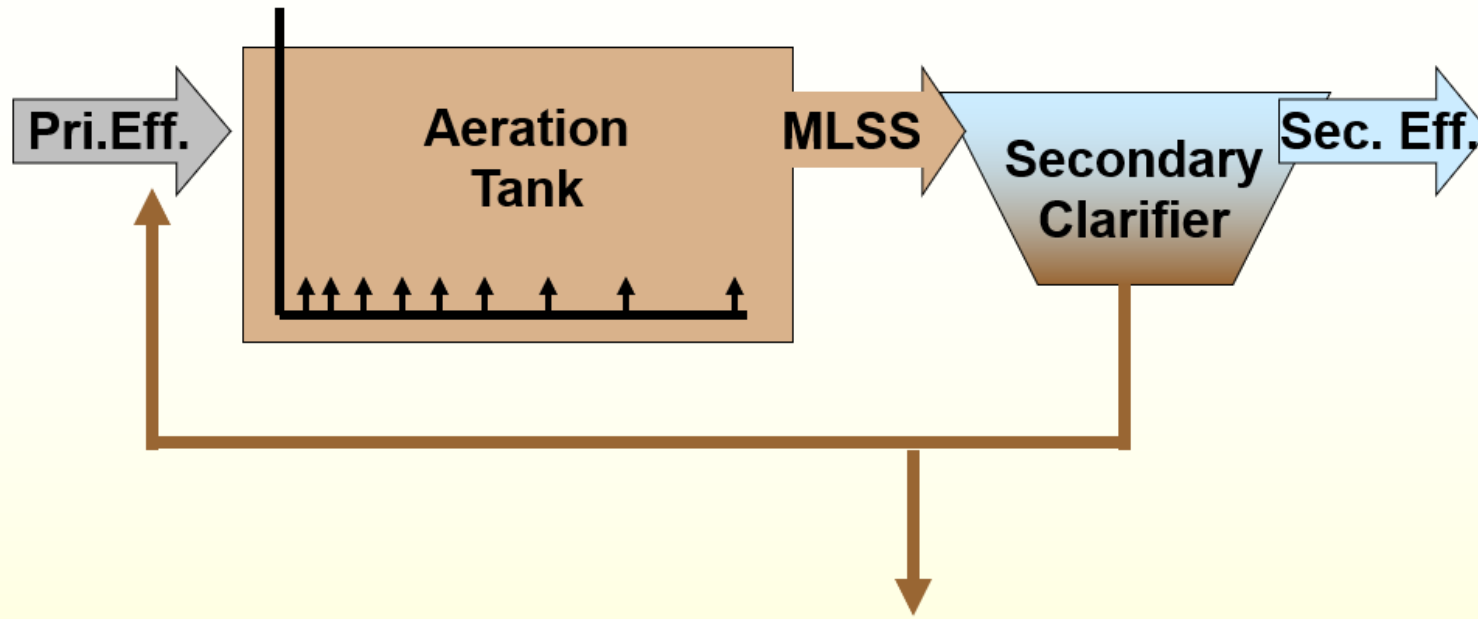

Example : An activated sludge plant receives 2.0 MGD from the primary clarifiers at 120 mg/L BOD. Calculate the organic loading (Lbs/Day BOD) on the activated sludge process.

- Solution

$$\text{Lbs/day} = \text{Conc. (mg/L)} \times \text{Flow (MGD)} \times 8.34 \frac{\text{Lbs}}{\text{gal}}$$

$$\frac{\text{Lbs}}{\text{Day}} = 120 \text{ mg/L} \times 2.0 \text{ MGD} \times 8.34 \frac{\text{Lbs}}{\text{Gal}}$$

$$= 2001.6 \frac{\text{Lbs BOD}}{\text{Day}}$$

Example

How many **pounds** of suspended solids leave a facility each day if the flow rate is **150,000 gal/day** and the concentration of suspended solids is **25 mg/L**

$$\text{Lbs/day} = \text{Conc. (mg/L)} \times \text{Flow (MGD)} \times \frac{8.34 \text{ Lbs}}{\text{gal}}$$

$$\text{Lbs/day} = 25 \text{ mg/L} \times \frac{150,000 \text{ gal/day}}{1,000,000 \text{ gal/MG}} \times \frac{8.34 \text{ Lbs}}{\text{gal}}$$

$$= 25 \times 0.15 \times 8.34$$

$$= \mathbf{31 \text{ Lbs/day}}$$

Example

How many pounds of MLVSS should be maintained in an aeration tank with a volume of 0.471 MG receiving primary influent BOD of 2502 lbs/d ? The desired F:M is 0.3.

What will be the MLVSS concentration in mg/L ?

$$\frac{F}{F/M} = M = \frac{2502 \text{ lbs/d}}{0.3} = 8340 \text{ lbs MLVSS}$$

$$8340 \text{ lbs} = \text{Conc} \times 0.471 \text{ MG} \times 8.34 \text{ lbs/gal}$$

$$\frac{8340 \text{ lbs}}{0.471 \text{ MG} \times 8.34 \text{ lbs/gal}} = 2123 \text{ mg/L}$$

Concentration must be expressed as parts per million parts.

Concentration is usually reported as milligrams per liter

This unit is equivalent to ppm..

$$\frac{1 \text{ mg}}{\text{liter}} = \frac{1 \text{ mg}}{1000 \text{ grams}} = \frac{1 \text{ mg}}{1,000,000 \text{ mg}} = \text{ppm}$$

$$\text{ppm} = \frac{\text{Parts}}{\text{Mil Parts}} = \frac{\text{Lbs.}}{\text{Mil Lbs.}}$$

Flow or Volume must be expressed as millions of gallons:

$$\frac{\text{gallons}}{1,000,000 \text{ gal/MG}} = \text{MG}$$

Determining MLSS

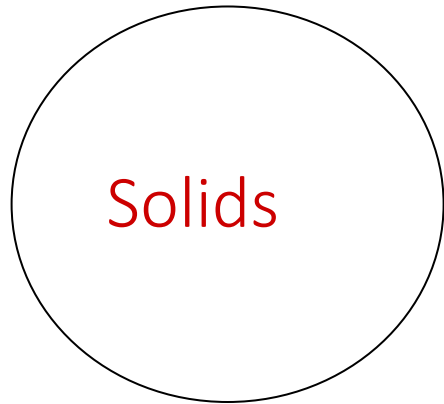

$$\frac{\text{Wt. of Solids + Paper, mg} - \text{Wt. of Paper, mg}}{\text{Wt. of Solids, mg}}$$

$$\frac{\text{Wt. of Solids, mg}}{\text{Volume of Sample, L}} \longrightarrow \text{MLSS, mg/L}$$

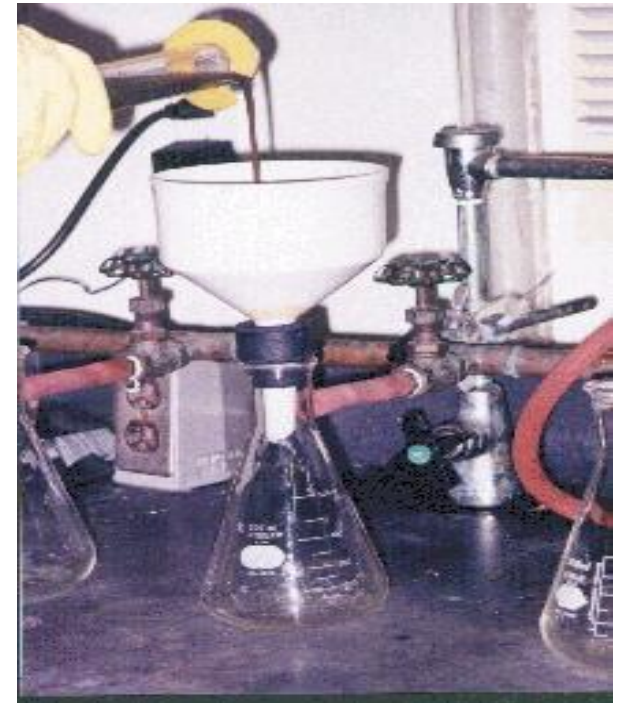

Determining MLVSS

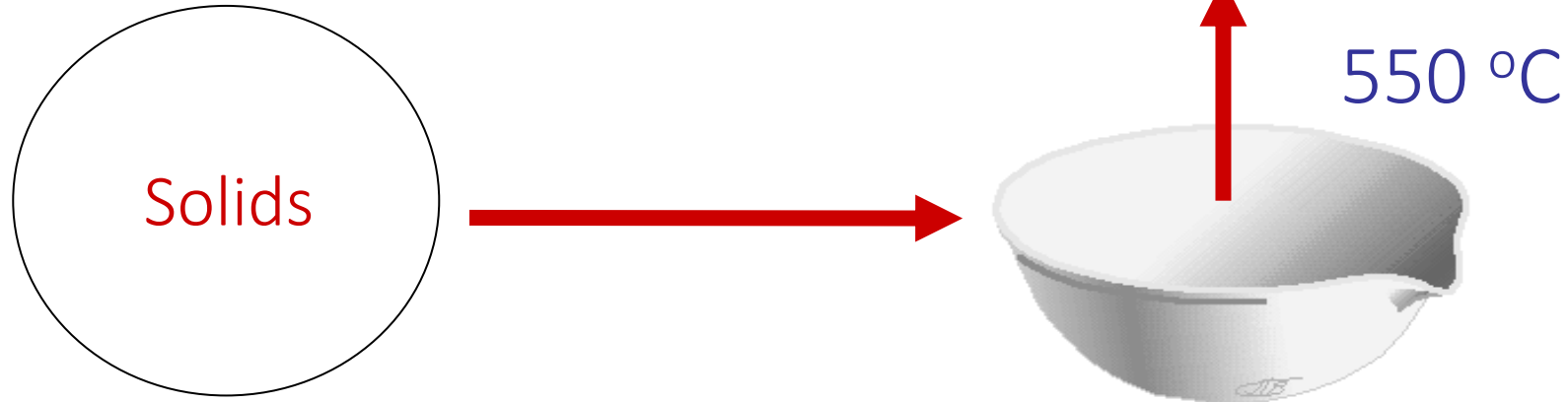

$$\frac{\text{Wt. of Dish + Solids, mg} - \text{Wt. of Dish + Ash, mg}}{\text{Wt. of Volatile Solids, mg}}$$

$$\frac{\text{Wt. of Volatile Solids, mg}}{\text{Volume of Sample, L}} \longrightarrow \text{MLVSS, mg/L}$$

Growth phases in a biological system

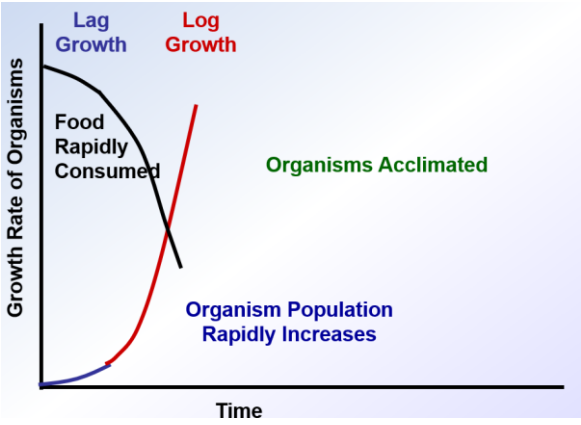
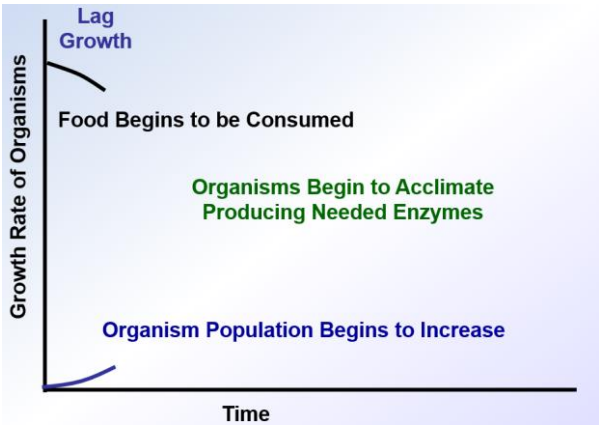
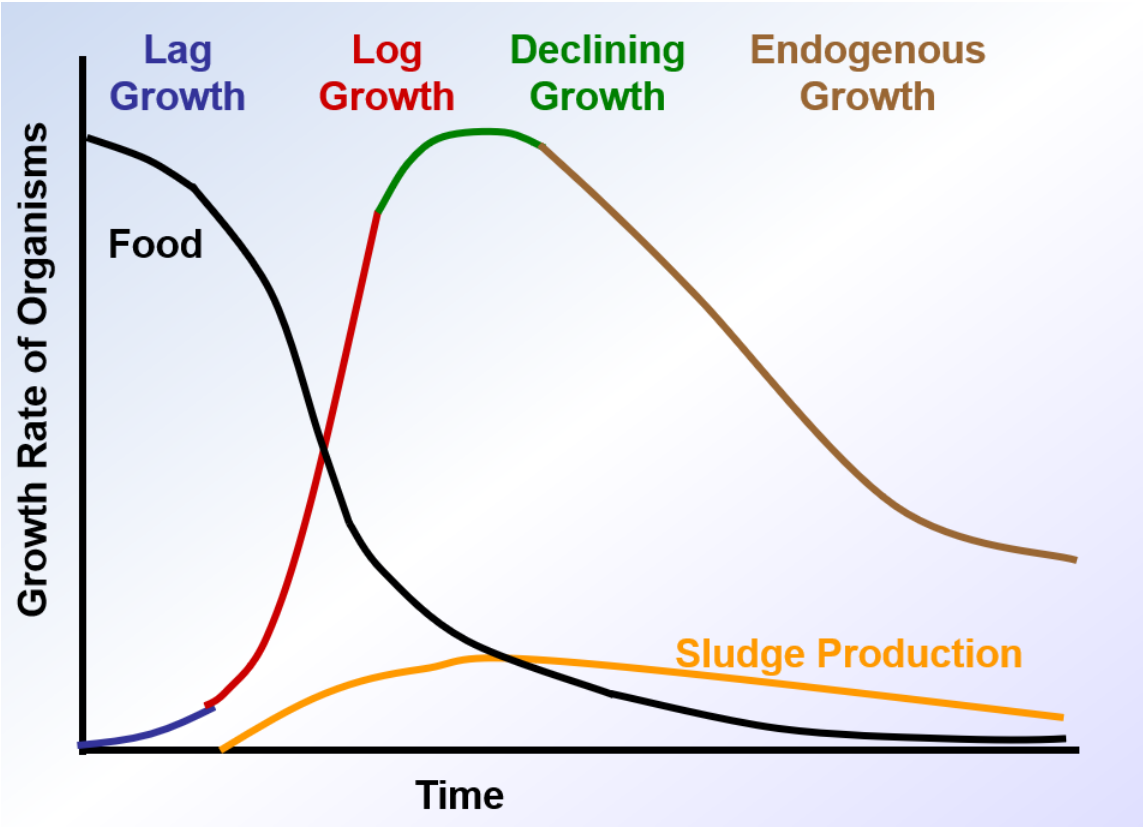
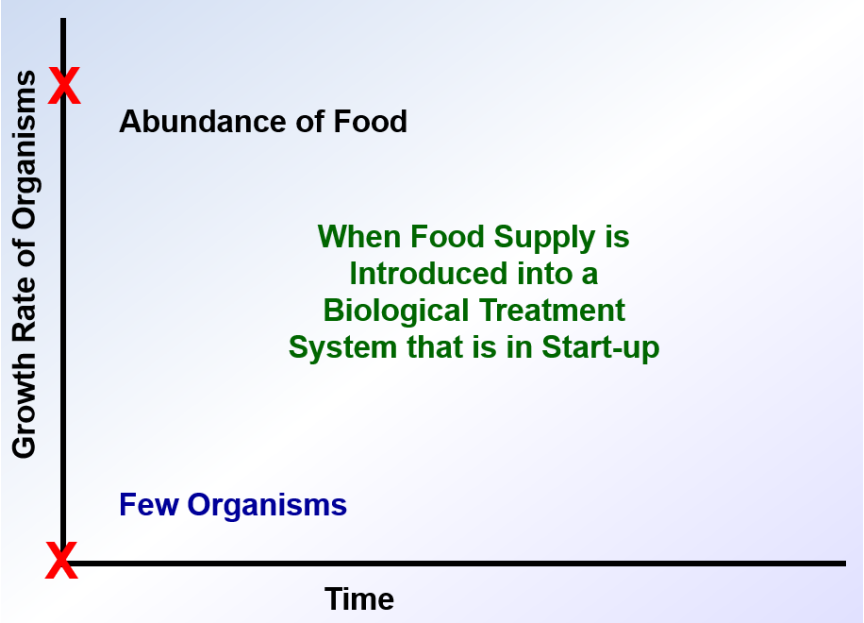

Design of activated sludge systems

- ❑ Volume of reactor/reactors (V)
- ❑ Number and dimensions of reactors
- ❑ Sludge produced per day (X_w) (digestion capacity & disposal)
- ❑ Oxygen required per day
- ❑ Clarifier design

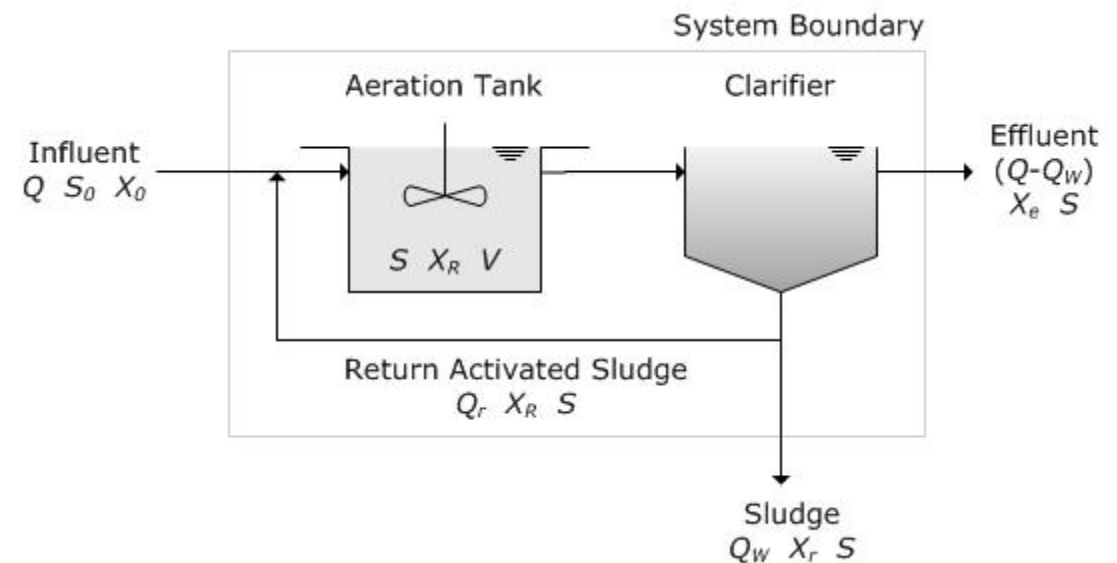

<https://www.youtube.com/watch?v= QtIJh0VJOU>

Mass Balance

Rate of mass accumulation = rate of mass inflow - rate of mass outflow ± rate of mass reacted

(+ generation, - degradation)

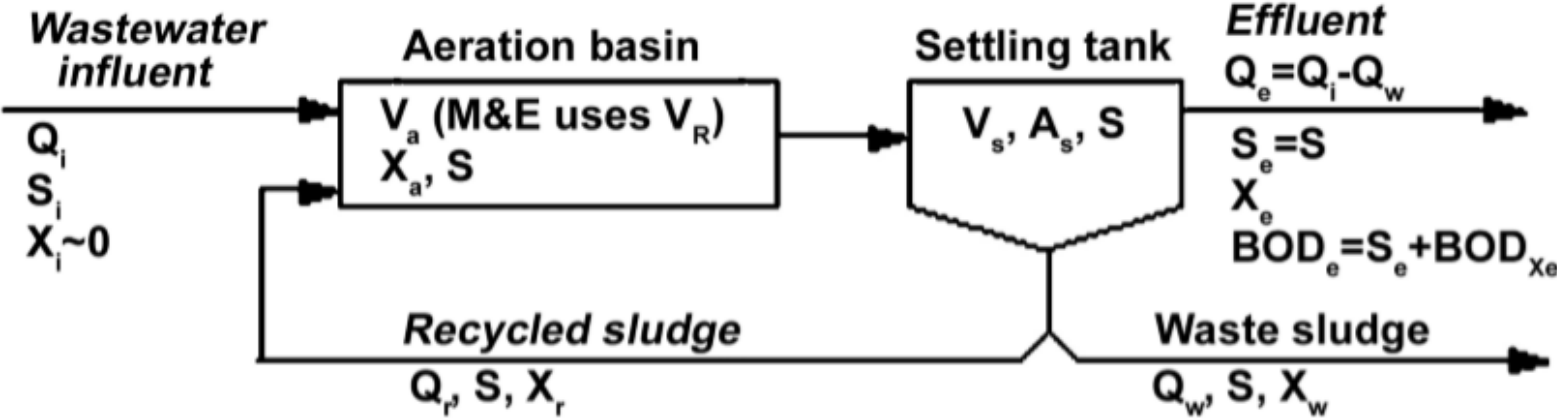

Q = volumetric flow rate
 S = soluble organic concentration (as BOD)
 X = cell concentration (VSS)

i = influent (0 for conc.)
 e = effluent stream
 r = recycle stream
 w = waste stream

Mass Balance

□ Assumptions:

- organic degradation occurs only in aeration basin
- often consider aeration basin residence time only (neglecting settling tank)
- usually X_i negligible and $X_r = X_w$

- ## □ Example:
- what is the rate of solids outflow (mass of cells/time) from the activated sludge system at steady state (accum = 0; typically used for design/analysis)?

$$\text{outflow} = Q_e X_e + Q_w X_w \approx Q_w X_w$$

(X_e usually ~3 orders of magnitude smaller than X_w)

Sludge Volume Index (SVI)

- Describes how well the sludge from the aeration tank settles and compacts.
- In order to calculate sludge volume index (SVI), two numbers are needed. The first number comes from a 30-minute settleability test, where 1 liter of the mixed liquor sample from the aeration tank is poured into a container called a settleometer. The sludge is allowed to settle for 30 minutes, and the volume of the settled sludge is measured in mL/L.
- The other number used in the sludge volume index (SVI) calculation comes from a MLSS test. It simply determines the suspended solids concentration of the sample from the aeration tank, in mg/L.

$$\text{SVI} \left(\frac{\text{mL}}{\text{gram}} \right) = \frac{\text{Settled sludge volume, } \frac{\text{mL}}{\text{L}}}{\text{Suspended solids concentration, } \frac{\text{mg}}{\text{L}}} \times \frac{1,000 \text{ mg}}{\text{gram}}$$

SVI <100 mL/g, good settle sludge

SVI >150 mL/g, poor settle sludge, filamentous growth



SVI Test

Filamentous bacteria

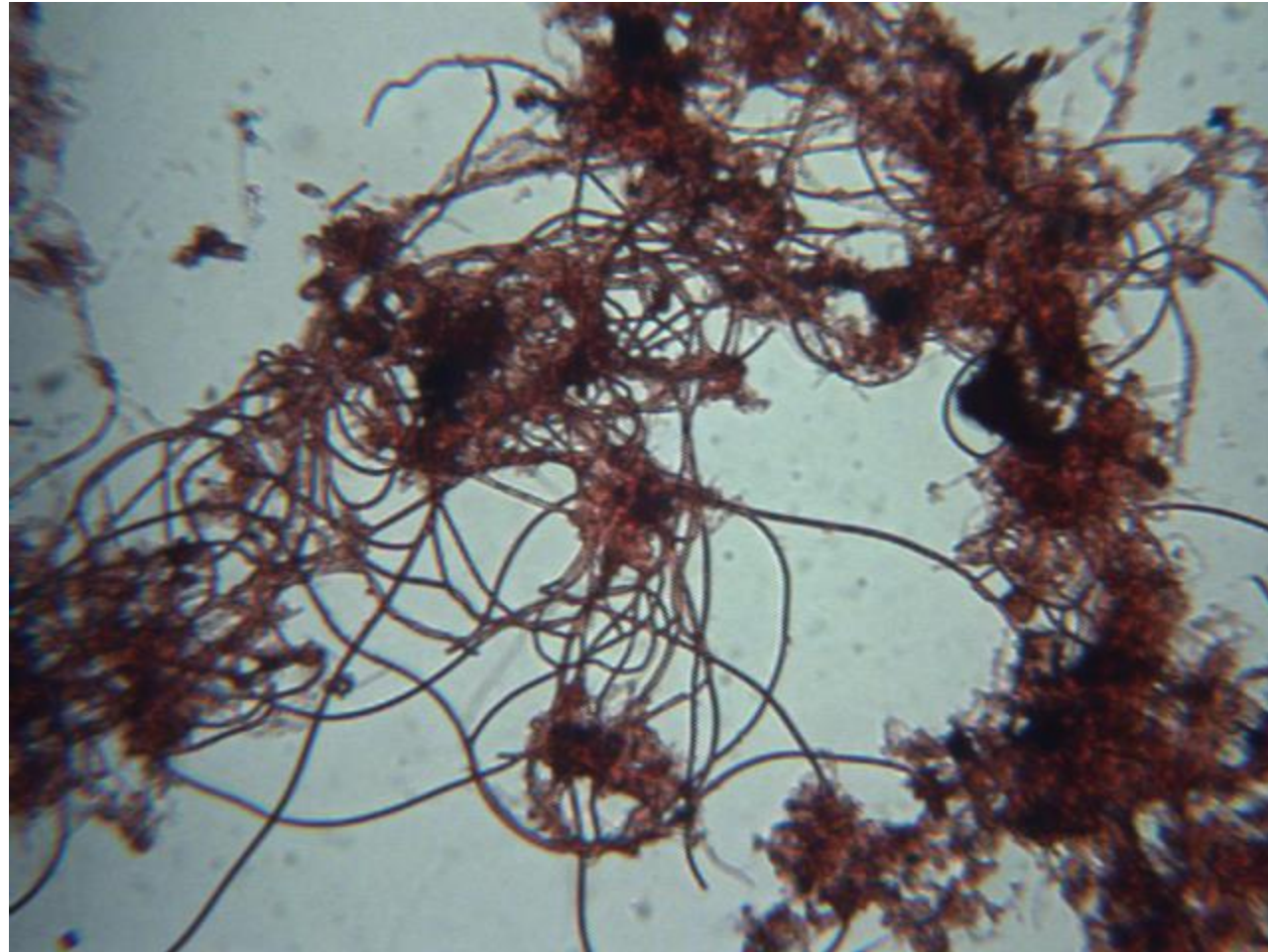

<https://www.youtube.com/watch?v=erf80dIE-Lw>

Example

Calculate the SVI for an activated sludge sample given the following:

30-minute settleable solids volume = 150 mL

MLSS = 3,000 mg/L

SVI, mL/g =

$$\frac{\text{settled sludge volume/sample volume (mL/L)} \times \frac{1,000\text{mg}}{1\text{gm}}}{\text{MLSS (mg/L)}}$$

$$\text{SVI} = \frac{150 \text{ mL/1L}}{3,000 \text{ mg/L}} \times \frac{1,000 \text{ mg}}{1 \text{ gm}} = 50 \text{ mL/g}$$

Cell growth kinetics

- Bacterial growth rate in batch or continuous systems

$$r_g = \frac{dX}{dt} = \mu X$$

- Monod Equation

$$\mu = \mu_m \frac{S}{K_s + S}$$

(Substrate limited growth):

$$r_g = \frac{\mu_m X S}{K_s + S}$$

- r_g = growth rate (mass/vol·time)
- μ = specific growth rate (1/time)
- μ_m = max. specific growth rate (1/time)
- X = cell concentration (mass/vol)
- S = conc. of growth-limiting substrate (mass/vol)
- K_s = half-velocity (or half-saturation) constant (mass/vol)

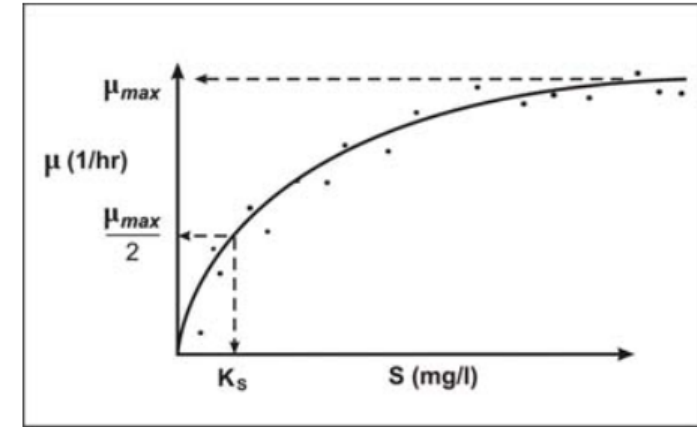

$$\mu = \mu_{max} \left(\frac{S}{S + K_s} \right)$$

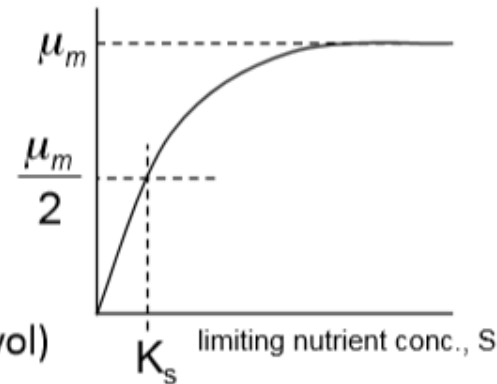

Cell growth and substrate utilization

- Substrate is converted to new cell and oxidized organic and inorganic end-products

$$r_g = -Yr_{su}$$

- Y = cell yield (mg/mg)
- r_{su} = substrate utilization rate (mass/vol·time)

$$r_{su} = -\frac{\mu_m X S}{Y(K_s + S)}$$

- $k = \mu_m/Y$ = max. rate of substrate utilization per mass of microorganisms

$$\Rightarrow r_{su} = -\frac{kXS}{(K_s + S)}$$

Monod equation

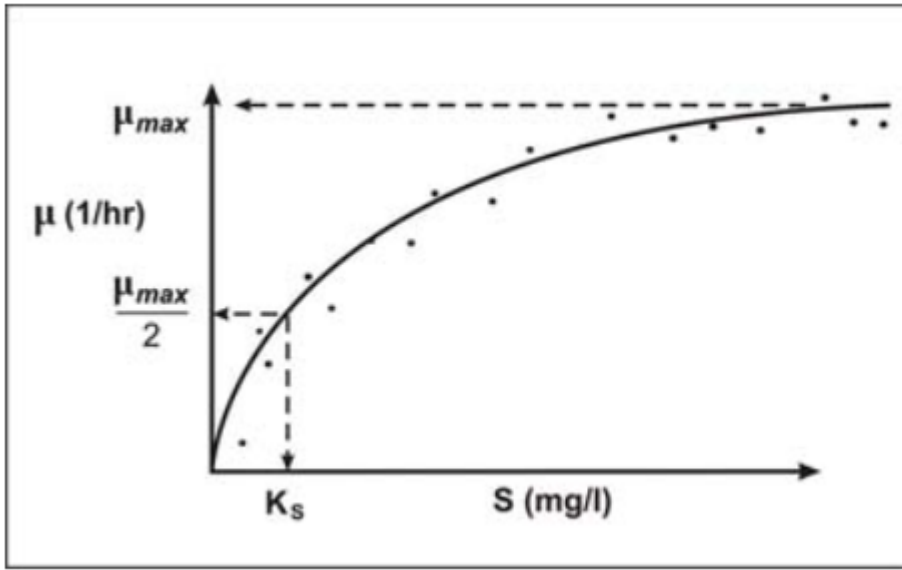

$$\mu = \mu_{max} \left(\frac{S}{S+K_s} \right)$$

Yield coefficient (Y)

$$Y = \frac{dX}{dS} = \frac{\text{mass of new cells}}{\text{mass of substrate consumed}}, [\text{dimensionless}]$$

Cell growth and substrate utilization

- Distribution of cell ages
- Death and predation

→ Need to correct growth rate $r_d = -k_d X$

$$r'_g = \frac{\mu_m X S}{K_s + S} - k_d X = -Y r_{su} - k_d X$$

$$\mu' = \mu_m \frac{S}{K_s + S} - k_d$$

- μ' = net specific growth rate (1/time)

$$Y_{obs} = -\frac{r'_g}{r_{su}}$$

Temperature effect

□ Temperature affects many processes during WW treatment

- Metabolic activity / growth rate
- Gas transfer
- Settling characteristics

$$r_T = r_{20} \theta^{(T-20)}$$

Process	θ value	
	Range	Typical
Activated sludge	1.00 – 1.08	1.04
Aerated lagoons	1.04 – 1.10	1.08
Trickling filters	1.02 – 1.08	1.035

Example

$\mu_{\max} = 3 \text{ day}^{-1}$, $K_s = 60 \text{ mg/l}$, $S = 150 \text{ mg/L}$. using monods equation determine
The growth rate constant (μ)

$$\mu = \mu_{\max} \left(\frac{S}{K_s + S} \right) \dots\dots (1)$$

Here, μ is the growth rate constant, μ_{\max} is the maximum value of growth rate, S is the substrate concentration, and K_s is the substrate concentration when $\mu = 0.5\mu_{\max}$.

Substitute 3.0 day^{-1} for μ_{\max} , 60 mg/l for K_s , 150 mg/l for S , 0 for t .

$$\begin{aligned} \mu &= \mu_{\max} \left(\frac{S}{K_s + S} \right) \\ &= (3.0) \left(\frac{150}{60 + 150} \right) \\ &= 2.14 \text{ day}^{-1} \end{aligned}$$

Therefore, the growth rate constant is $\boxed{2.14 \text{ day}^{-1}}$.

Application of growth kinetic on wastewater

- ❑ Microorganism–Substrate balance
- ❑ Prediction of effluent microorganism and substrate concentrations
- ❑ First look at aerobic open system in a completely stirred tank reactor (CSTR) with recycle

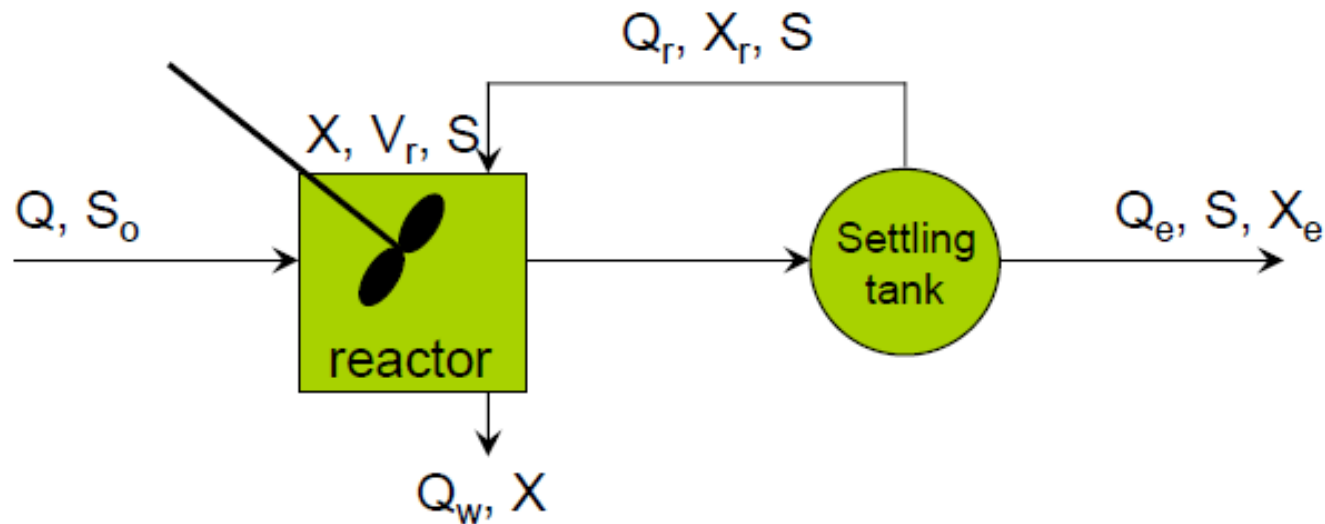

Microorganisms mass balance

Accumulation = inflow – outflow + net growth

Rate of accumulation of μO within system boundary = Rate of flow of μO into system boundary – Rate of flow of μO out of system boundary + Net growth of μO within system boundary

$$\frac{dX}{dt} V_r = QX_o - QX + V_r r'_g = 0$$

dX/dt = rate of change of μO in the reactor (mass VSS/vol· time)

V_r = reactor volume

Q = flowrate (vol/time)

X_o = influent μO concentration (mass VSS/vol)

X = reactor μO concentration (mass VSS/vol)

r'_g = net rate of μO growth (mass VSS/vol· time)

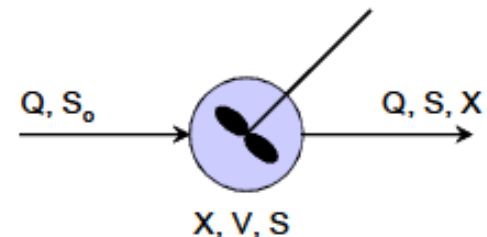

Microorganisms mass balance

$$\frac{dX}{dt}V_r = QX_o - QX + V_r r'_g \qquad r'_g = \frac{\mu_m XS}{K_s + S} - k_d X$$
$$\frac{dX}{dt}V_r = QX_o - QX + V_r \left(\frac{\mu_m XS}{K_s + S} - k_d X \right)$$

dX/dt = rate of change of MO in the reactor (mass VSS/vol· time)

V_r = reactor volume

Q = flowrate (vol/time)

X_o = influent MO concentration (mass VSS/vol)

X = reactor MO concentration (mass VSS/vol)

r'_g = net rate of MO growth (mass VSS/vol· time)

S = substrate concentration in effluent (mg/l)

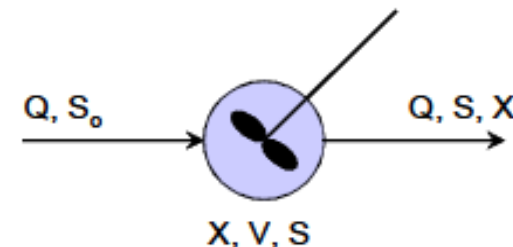

Microorganisms mass balance

□ Assumptions:

- X_0 negligible
- System in steady state conditions $\rightarrow dX/dt = 0$

$$\frac{Q}{V_r} = \frac{1}{\theta_c} = \frac{\mu_m S}{K_s + S} - k_d$$

$$\theta_c = \frac{V_r X}{QX} = \frac{V_r}{Q}$$

- θ_c = mean cell residence time (SRT)

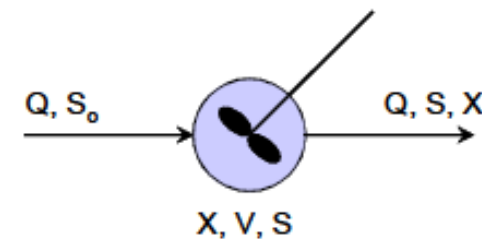

Mass balance of food substrate

□ Substrate mass balance:

$$\frac{dS}{dt}V_r = QS_o - QS - V_r \left(\frac{kXS}{K_s + S} \right)$$

■ At steady state $dS/dt = 0$

$$S_o - S - \theta \left(\frac{kXS}{K_s + S} \right) = 0$$

Effluent microorganisms and substrate concentration

$$S_o - S - \theta \left(\frac{kXS}{K_s + S} \right) = 0 \quad \longleftarrow \quad \frac{Q}{V_r} = \frac{1}{\theta} = \frac{\mu_m S}{K_s + S} - k_d$$

$$X = \frac{\mu_m (S_o - S)}{k(1 + k_d \theta)} = \frac{Y(S_o - S)}{(1 + k_d \theta)}$$

Similarly:

$$S = \frac{K_s(1 + \theta k_d)}{\theta(Yk - k_d) - 1}$$

Mass balance

Combine the mass balance equations for food and biomass:

$$\frac{Q_w V_w}{VX} + k_d = \frac{Q_o Y}{VX} (S_o - S)$$

- The cell residence time is:

$$\theta_c = \frac{VX}{Q_w X_w}$$

- The hydraulic retention time is $= V/Q_o$

» Substitute and rearrange:

$$X = \frac{\theta_c Y}{\theta} \left(\frac{S_o - S}{1 + k_d \theta_c} \right) \qquad \frac{1}{\theta_c} = \frac{Y(S_o - S)}{\theta X} - k_d$$

- Compute the F/M ratio

$$\frac{F}{M} = \frac{S_o}{\theta X}$$

$$\frac{F}{M} = \frac{S_o}{(V/Q_o)X} = \frac{Q_o S_o}{VX}$$

Typical Values

Coefficient	Units	Range	Typical
K_s (half-velocity constant)	mg/L BOD ₅	25-100	60
K_s (half-velocity constant)	mg/L COD	15-70	40
k (max. rate of substrate utilization per mass of microorganism)	d ⁻¹	2-10	5
k_d (endogenous decay rate constant)	d ⁻¹	0.025-0.075	0.06
Y (cell yield)	mg VSS/mg BOD ₅	0.4-0.8	0.6

Sludge Production

- Important for design of solid waste handling infrastructure
- Values are needed to calculate oxygen requirement

$$P_x = Y_{obs} Q (S_o - S) \times [8.34 \text{ lb} / (\text{Mgal} \cdot (\text{mg} / \text{l}))] \quad \text{US units}$$

$$P_x = Y_{obs} Q (S_o - S) \times (10^3 \text{ g} / \text{kg})^{-1} \quad \text{SI units}$$

$$Y_{obs} = \frac{Y}{1 + k_d \theta_c}$$

Oxygen requirement

- Can be estimated from influent BOD_5 and amount of organism wasted per day
- Relationship between BOD_5 and BOD_L
 - $f \equiv$ conversion factor (0.45 – 0.68)
- Relationship between BOD_L and cell calculated from stoichiometry to be 1.42

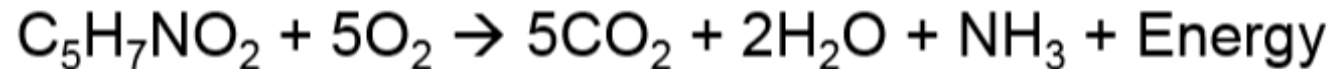

113	5(32)
cells	oxygen
1	1.42

$$Y_{obs} = \frac{Y}{1 + k_d \theta_c}$$

Oxygen requirement

$$\text{lb } O_2 / \text{day} = \frac{Q(S_o - S) \cdot 8.34}{f} - 1.42(P_x)$$

$$\text{kg } O_2 / \text{day} = \frac{Q(S_o - S) \cdot (10^3 \text{ g / kg})^1}{f} - 1.42(P_x)$$

□ When nitrification is considered:

$$\text{lb } O_2 / \text{day} = \frac{Q(S_o - S) \cdot 8.34}{f} - 1.42(P_x) + 4.57Q(N_o - N) \cdot 8.34$$

$$\text{kg } O_2 / \text{day} = \frac{Q(S_o - S) \cdot (10^3 \text{ g / kg})^1}{f} - 1.42(P_x) + 4.57Q(N_o - N) \cdot (10^3 \text{ g / kg})^1$$

➤ 4.57 = conversion factor for complete oxidation of TKN

Example

An activated sludge system is to be used for secondary treatment of 10,000 m³/day of municipal wastewater. After primary clarification, the BOD is 150 mg/L, and it is desired to have not more than 5 mg/L of soluble BOD in the effluent. A completely mixed reactor is to be used, and pilot - plant analysis has established the following kinetic values

$$Y = 0.5 \text{ kg / kg}$$

$$k_d = 0.05 \text{ 1 / day}$$

$$\theta_c = 10 \text{ day}$$

Assuming an MLSS concentration of 3,000 mg/L and an underflow concentration of 10,000 mg/L from the secondary clarifier, determine

Calculate

- The volume of the reactor
- The mass and volume of solids that must be wasted each day

The recycle ratio

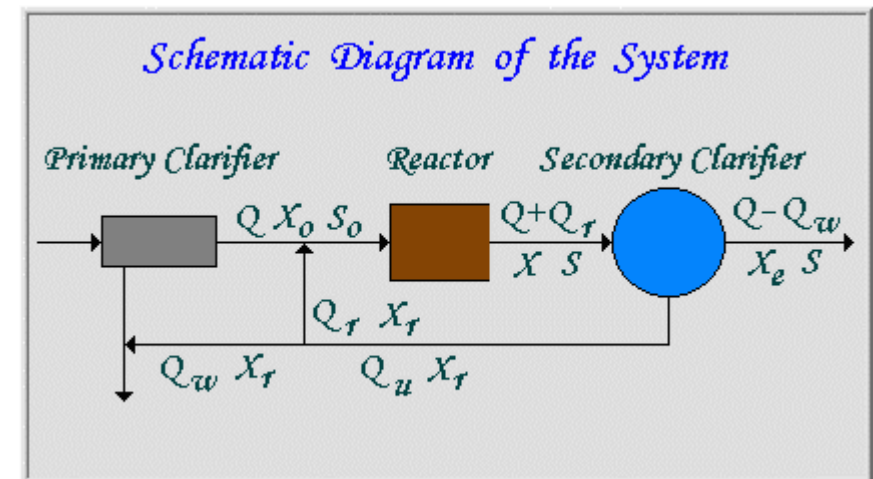

a.

$$\frac{1}{\theta_c} = \frac{(Q)(Y)(S_0 - S)}{(V_r)(X)} - k_d$$

$$\left. \begin{array}{l} \theta_c = 10 \text{ day (Selected)} \\ Q = 10,000 \text{ m}^3/\text{day} \\ Y = 0.5 \text{ kg/kg} \\ S_0 = 0.15 \text{ kg/m}^3 \\ S = 0.005 \text{ kg/m}^3 \\ X = 3.0 \text{ kg/m}^3 \\ k_d = 0.05 \text{ 1/day} \end{array} \right\} V_r: \text{Reactor Volume} = 1,611 \text{ m}^3$$

b.

$$\theta_c = \frac{(V_r)(X)}{(Q_w)(X_r)}$$

$$\left. \begin{array}{l} \theta_c = 10 \text{ day (Selected)} \\ V_r = 1,611 \text{ m}^3 \\ X = 3.0 \text{ kg/m}^3 \\ X_r = 10 \text{ kg/m}^3 \end{array} \right\} \begin{array}{l} \text{Mass of Excess Solids} \\ (Q_w)(X_r) = 483.3 \text{ kg/day} \\ \text{Volume of Excess Solids} \\ Q_w = 48.3 \text{ m}^3/\text{day} \end{array}$$

C.

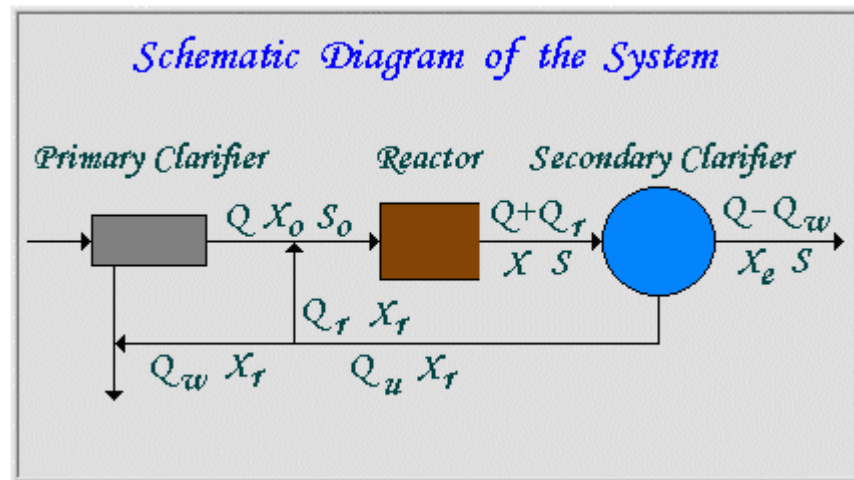

$$(Q + Q_r)(X) = (Q + Q_r - Q_w)(X_e) + (Q_r + Q_w)(X_r)$$

$$X_e = 0 \text{ kg/m}^3 \text{ (Assumed)}$$

$$Q_r = \frac{(Q)(X) - (Q_w)(X_r)}{X_r - X}$$

$$Q_r = 4,217 \text{ m}^3/\text{day}$$

$$\text{Recirculation Ratio} = \frac{4,217}{10,000} = 0.42$$

Example

- Calculate oxygen requirement of a complete - mix activated sludge process treating domestic wastewater having flowrate of $0.25 \text{ m}^3/\text{sec}$. BOD_5 concentration of settled wastewater is 250 mg/L . The effluent soluble BOD_5 is 6.2 mg/L . Increase in the mass of MLVSS is $1,646 \text{ kg/day}$. Assume that the temperature is $20 \text{ }^\circ\text{C}$ and the conversion factor, $\text{BOD}_5 / \text{BOD}_L$ is 0.68 .

$$O_2 = \frac{(Q)(S_0 - S)(10^3 \text{ g/kg})^{-1}}{f} - (1.42)(P_x)$$

$$Q = 0.25 \text{ m}^3/\text{sec} = 21,600 \text{ m}^3/\text{day}$$

$$S_0 = 250 \text{ g/m}^3$$

$$S = 6.2 \text{ g/m}^3$$

$$f = 0.68$$

$$P_x = 1,646 \text{ kg/day}$$

$$O_2 = 5,407 \text{ kg/day}$$

Biological treatment handout

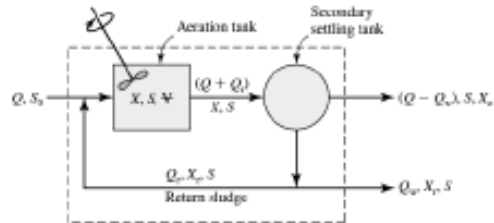

FIGURE 8-16
Completely mixed biological reactor with solids recycle.

$$\text{Biomass in influent} + \text{Net biomass growth} = \text{Biomass in effluent} + \text{Biomass wasted} \quad (8-8)$$

The biomass in the influent is the product of the concentration of microorganisms in the influent (X_0) and the flow rate of wastewater (Q). The concentration of microorganisms in the influent (X_0) is measured as suspended solids (mg/L). The biomass that grows in the aeration tank is the product of the volume of the tank (V) and the Monod expression for growth of microbial mass (Equation 8-5)

$$V \left(\frac{\mu_m SX}{K_s + S} - k_d X \right) \quad (8-9)$$

The biomass that is wasted is the product of concentration of microorganisms in the WAS flow (X_w) and the WAS flow rate (Q_w). The narrative mass balance equation may be rewritten as

$$QX_0 + V \left(\frac{\mu_m SX}{K_s + S} - k_d X \right) = (Q - Q_w)X_e + Q_w X_w \quad (8-10)$$

At steady-state, the mass balance equation for food (soluble BOD₅) may be written

$$\text{Food in influent} - \text{Food consumed} = \text{Food in effluent} + \text{Food in WAS} \quad (8-11)$$

The food in the influent is the product of the concentration of soluble BOD₅ in the influent (S_0) and the flow rate of wastewater (Q). The food that is consumed in the aeration tank is the product of the volume of the tank (V) and the expression for rate of food utilization (Equation 8-7)

$$V \left(\frac{\mu_m SX}{Y(K_s + S)} \right) \quad (8-12)$$

The food in the waste activated sludge flow is the product of the concentration of soluble BOD₅ in the influent (S) and the WAS flow rate (Q_w). The narrative mass balance equation for steady-state conditions may be rewritten as

$$QS_0 - V \left(\frac{\mu_m SX}{Y(K_s + S)} \right) = (Q - Q_w)S + Q_w S \quad (8-13)$$

where Y = yield coefficient (see Equation 8-6).

Biological treatment handout

<p>The variables are summarized as follows:</p> <p>Q = wastewater flow rate into the aeration tank, m^3/d X_0 = microorganism concentration (volatile suspended solids or VSS)* entering aeration tank, mg/L V = volume of aeration tank, m^3 μ_m = maximum growth rate constant, d^{-1} S = soluble BOD_5 in aeration tank and effluent, mg/L X = microorganism concentration (mixed-liquor volatile suspended solids or MLVSS)[†] in the aeration tank, mg/L K_s = half velocity constant = soluble BOD_5 concentration at one-half the maximum growth rate, mg/L k_d = decay rate of microorganisms, d^{-1} Q_w = flow rate of liquid containing microorganisms to be wasted, m^3/d X_r = microorganism concentration (VSS) in effluent from secondary settling tank, mg/L X_w = microorganism concentration (VSS) in sludge being wasted, mg/L</p>	
<p>To develop working design equations we make the following assumptions:</p> <ol style="list-style-type: none"> 1. The influent and effluent biomass concentrations are negligible compared to that in the reactor. 2. The influent food (S_0) is immediately diluted to the reactor concentration in accordance with the definition of a CSTR (see Chapter 2). 3. All reactions occur in the CSTR. <p>From the first assumption we may eliminate the following terms from Equation 8-10: QX_0 and $(Q - Q_w)X_r$ because X_0 and X_r are negligible compared to X. Equation 8-10 may be simplified to</p> $(V) \left(\frac{\mu_m SX}{K_s + S} - k_d X \right) = +Q_w X_r \quad (8-14)$ <p>For convenience, we may rearrange Equation 8-14 in terms of the Monod equation</p> $\left(\frac{\mu_m S}{K_s + S} \right) = \frac{Q_w X_r}{VX} + k_d \quad (8-15)$	<p>Equation 8-13 may also be rearranged in terms of the Monod equation</p> $\left(\frac{\mu_m S}{K_s + S} \right) = \frac{Q}{V} \frac{Y}{X} (S_0 - S) \quad (8-16)$ <p>Noting that the left side of Equations 8-15 and 8-16 are the same, we set the right-hand side of these equations equal and rearrange to give:</p> $\frac{Q_w X_r}{VX} = \frac{Q}{V} \frac{Y}{X} (S_0 - S) - k_d \quad (8-17)$

Biological treatment handout

Noting that the left side of Equations 8-15 and 8-16 are the same, we set the right-hand side of these equations equal and rearrange to give:

$$\frac{Q_w X_r}{VX} = \frac{Q}{V} \frac{Y}{X} (S_o - S) - k_d \quad (8-17)$$

Two parts of this equation have physical significance in the design of a completely mixed activated sludge system. The inverse of Q/V is the *hydraulic detention time* (t_o) of the reactor:

$$\frac{V}{Q} = t_o \quad (8-18)$$

The inverse of the left side of Equation 8-17 defines the *mean cell-residence time* (θ_c):

$$\frac{VX}{Q_w X_r} = \theta_c \quad (8-19)$$

Biological treatment handout

The mean cell-residence time expressed in Equation 8-19 must be modified if the effluent biomass concentration is not negligible. Equation 8-20 accounts for effluent losses of biomass in calculating θ_c .

$$\theta_c = \frac{VX}{Q_e X_r + (Q - Q_e)(X_c)} \quad (8-20)$$

From Equation 8-15, it can be seen that once θ_c is selected, the concentration of soluble BOD₅ in the effluent (S) is fixed:

$$S = \frac{K_s(1 + k_d\theta_c)}{\theta_c(\mu_m - k_d) - 1} \quad (8-21)$$

Typical values of the microbial growth constants are given in Table 8-10. Note that the concentration of soluble BOD₅ leaving the system (S) is affected only by the mean cell-residence time and not by the amount of BOD₅ entering the aeration tank or by the hydraulic detention time. It is also important to reemphasize that S is the soluble BOD₅ and not the total BOD₅. Some fraction of the suspended solids that do not settle in the secondary settling tank also contributes to the BOD₅ load to the receiving body. To achieve a desired effluent quality both the soluble and insoluble fractions of BOD₅ must be considered. Thus, to use Equation 8-21 to achieve a desired effluent quality (S) by solving for θ_c , some estimate of the BOD₅ of the suspended solids must be made first. This value is then subtracted from the total allowable BOD₅ in the effluent to find the allowable S :

$$S = \text{Total BOD}_5 \text{ allowed} - \text{BOD}_5 \text{ in suspended solids} \quad (8-22)$$

From Equation 8-17, it is also evident that the concentration of microorganisms in the aeration tank is a function of the mean cell-residence time, hydraulic detention time, and difference between the influent and effluent concentrations:

$$X = \frac{\theta_c(Y)(S_o - S)}{t_d(1 + k_d\theta_c)} \quad (8-23)$$

TABLE 8-10
Values of growth constants for domestic wastewater^a

Parameter	Basis	Value ^b	
		Range	Typical
K_s	mg/L BOD ₅	25–100	60
k_d	d ⁻¹	0–0.30	0.10
μ_m	d ⁻¹	1–8	3
Y	mg VSS/mg BOD ₅	0.4–0.8	0.6

^aSources: Metcalf & Eddy, Inc., 2003, and Shabirani et al., 2006.

^bValues are for 20°C.

Example 1

What is the volume of a tank in gallons if it is 12 feet deep and has a diameter of 30 feet?
How many hours will it take to fill the tank if the flow entering them is 1.3MGD?

Example 1

$$\begin{aligned} V &= \text{Area} \times d \\ &= \frac{\pi (30)^2}{4} \times 12 \Rightarrow V = 8482.293 \text{ ft}^3 \end{aligned}$$

$$8482.293 \text{ ft}^3 \cdot \frac{(0.3048)^3 (\text{m})^3}{1 \text{ ft}^3} \cdot \frac{1000 \text{ L}}{1 \text{ m}^3} \cdot \frac{1 \text{ gal}}{3.785 \text{ L}}$$

1 ft³ = 7.48 gal

$$V = 63458.86 \text{ gal}$$

$$t = \frac{V}{Q}$$

$$= \frac{63458.86 \text{ gal}}{1.3 \times 10^6 \text{ gal}} \cdot \text{day} \cdot \frac{24 \text{ hr}}{1 \text{ day}}$$

$$t = 1.2 \text{ hr}$$

Example 2

What is the mixed liquor suspended solids concentration given the following?

Initial weight of filter disk = 0.45 gm

Volume of filtered sample = 60 mL

Weight of filter disk and filtered residue = 0.775 gm

Example 2

$$\text{MLSS} = \frac{W}{V} \quad (\text{mg/L})$$

$$= \frac{W_{\text{filter+residue}} - W_{\text{empty filter}}}{V}$$

$$= \frac{(0.775 - 0.450) \text{ g}}{60} \cdot \frac{1000 \text{ mL}}{1 \text{ L}} \cdot \frac{1000 \text{ mg}}{1 \text{ g}}$$

$$\Rightarrow \text{MLSS} = 5417 \text{ mg/L}$$

Example 3

A wastewater treatment facility has three primary clarifiers available for use. They are all circular clarifiers with a radius of 40ft and a depth of 8ft. The design engineer wants you to maintain a primary clarification detention time of approximately 3.5 hours. How many tanks will you need to use if the plant flow rate is approximately 2MGD?

Example 3

$$t = \frac{V}{Q}$$

$$= \frac{(\pi/4)(40+2)^2 \times 8 \text{ ft}^3}{2 \times 10^6 \text{ gal}} \cdot \text{day} \cdot \frac{7.48 \text{ gal}}{1 \text{ ft}^3}$$

$$t = 0.15 \text{ day}$$

$$= 3.6 \text{ hr}$$

Since $3.6^{\text{hr}} > 3.5^{\text{hr}} \Rightarrow$ You only need one tank

Example 4

A rectangular primary clarifier is 75 feet long, 22 feet wide and 10 feet deep. If it receives a flow of 1,250,000 gallons per day, what is the detention time in hours?

Example 4

$$t = \frac{V}{Q}$$

$$= \frac{75 \cdot 22 \cdot 10 \text{ ft}^3}{1.25 \cdot 10^6 \text{ gal}} \cdot \text{day} \cdot \frac{7.48 \text{ gal}}{1 \text{ ft}^3}$$

$$t = 0.099 \text{ day}$$

$$= 2.4 \text{ hr}$$

Example 5

For a facility, the influent Flow = 1.2 MGD, Influent CBOD= 230 mg/l

Aeration System Volume 250,000 gal.

MLVSS = 2500mg/l

Calculate F/M

Example 5

$$\frac{F}{M}$$

$$F \text{ loading} = \text{Conc.} \times Q \times 8.34$$

$$= 230 \times 1.2 \times 8.34$$

$$\Rightarrow F = 2301.84 \text{ lb/day}$$

$$M \text{ loading} = \text{Conc.} \times V(Q) \times 8.34$$

$$= 2500 \times 2.5 \times 10^{-1} \times 8.34$$

$$\Rightarrow M = 5212.5 \text{ lb/day}$$

$$F/M = \frac{2301.84}{5212.50}$$

$$= 0.44 \frac{\text{lb BOD}}{\text{lb M}}$$

Example 6

Design a complete mixed activated sludge process aeration tank for treatment of 4 MLD sewage having BOD concentration of 180 mg/L. The effluent should have soluble BOD of 20 mg/L or less. Consider the following:

MLVSS/MLSS = 0.8

Return sludge SS concentration = 10000 mg/L

MLVSS in aeration tank = 3500 mg/L

Mean cell residence time adopted in design is 10 days

- BOD treatment efficiency.
- Reactor Volume.
- Hydraulic retention time (HRT, θ).
- F/M
- Quantity of sludge waste.
- Sludge waste volume.
- Q_R .
- Oxygen requirement.

Example 6

- BOD treatment efficiency = η

$$\begin{aligned}\eta &= \frac{180 - 20}{180} \times 100 \\ &= 88.89\%\end{aligned}$$

- Reactor Volume

$$\begin{aligned}V &= \frac{Q \theta_c Y (S_0 - S)}{X (1 + K_d \theta_c)} \\ &= \frac{4000 \times 10 \times 0.5 (180 - 20)}{3500 (1 + 0.06 \times 10)} \\ &= 571.43 \text{ m}^3\end{aligned}$$

- Hydraulic retention time (HRT, θ)

$$\begin{aligned}\theta &= \frac{V}{Q} \\ &= \frac{571.43 \text{ m}^3}{4000 \text{ m}^3} \cdot \text{day} \cdot 24 \text{ hr} \\ &= 3.43 \text{ hr}\end{aligned}$$

- F/M

$$\begin{aligned}\frac{F}{M} &= \frac{Q S_0}{V X} = \frac{4000 \times 180}{571.43 \times 3500} \\ \Rightarrow \frac{F}{M} &= 0.36 \frac{\text{Kg BOD}}{\text{Kg VSS}}\end{aligned}$$

- Quantity of sludge waste

$$P_x = Y_{obs} Q_0 (S_0 - S) \times 10^{-3}$$

$$Y_{obs} = \frac{Y}{(1 + k_d \theta_c)}$$
$$= \frac{0.5}{1 + 0.06 \times 10}$$

$$= 0.3125 \text{ mg/mg}$$

Therefore,

$$P_x = 0.3125 \times 4000 \times (180 - 20) \times 10^{-3}$$

$$= 200 \text{ Kg/day (VSS)}$$

$$+ \text{SS} = \frac{200}{0.8} = 250 \text{ Kg/day}$$

- Sludge waste volume

$$\theta_c = \frac{VX}{Q_w X_r}$$

$$10 = \frac{571.43 \times 3500}{Q_w \times 10,000 \times 0.8}$$

$$\Rightarrow Q_w = 25.0 \text{ m}^3/\text{day}$$

- Recirculation ratio

$$X(Q + Q_r) = X_r Q_r$$

$$\Rightarrow 3500(Q + Q_r) = 8000 Q_r$$

$$\frac{Q_r}{Q} = 0.78$$

- Oxygen requirement

$$\begin{aligned} O_2 &= \frac{Q(S_0 - S)}{f} - 1.42 Q_w X_r \\ &= \frac{4000(180 - 20)}{0.68} - 1.42 * 25 * 8000 * 10^{-3} \\ &= 657.17 \text{ kg } O_2 / \text{day} \end{aligned}$$

Example 7

Design conventional ASP to treat soluble wastewater from bottle washing plant contains a soluble organic waste having a COD of 300 mg/l. From extensive laboratory studies the BOD₅/COD ratio was found to be 0.60. The average flow rate of 1.0 MLD is to be treated so that effluent SS and BOD₅ should be less than 20 mg/L. Consider following conditions is applicable.

- 1. Influent VSS are negligible
- 2. Return sludge concentration = 8000 mg/L as SS = 6400 mg/L as VSS
- 3. MLSS = 2500 mg/l
- 4. MLVSS/MLSS = 0.8
- 5. Mean cell residence time $\theta_c = 8$ days
- 6. $Y = 0.50$ kg cells/ kg substrate (COD) consumed, $K_d = 0.06 \text{ d}^{-1}$
- 7. It is estimated that 80% of effluent solids are biodegradable consider $\text{BOD}_u = \text{COD}$ for solids and $\text{BOD}_5 = 0.6 \text{ COD}$

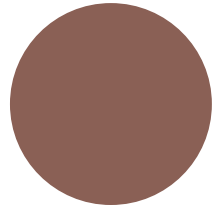
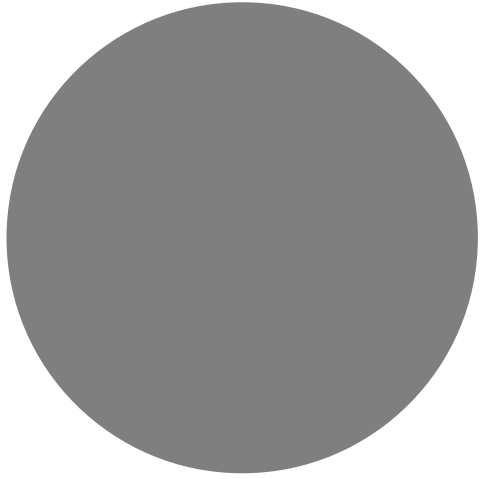

Wastewater Treatment Engineering
CE 11401455

Coagulation and flocculation



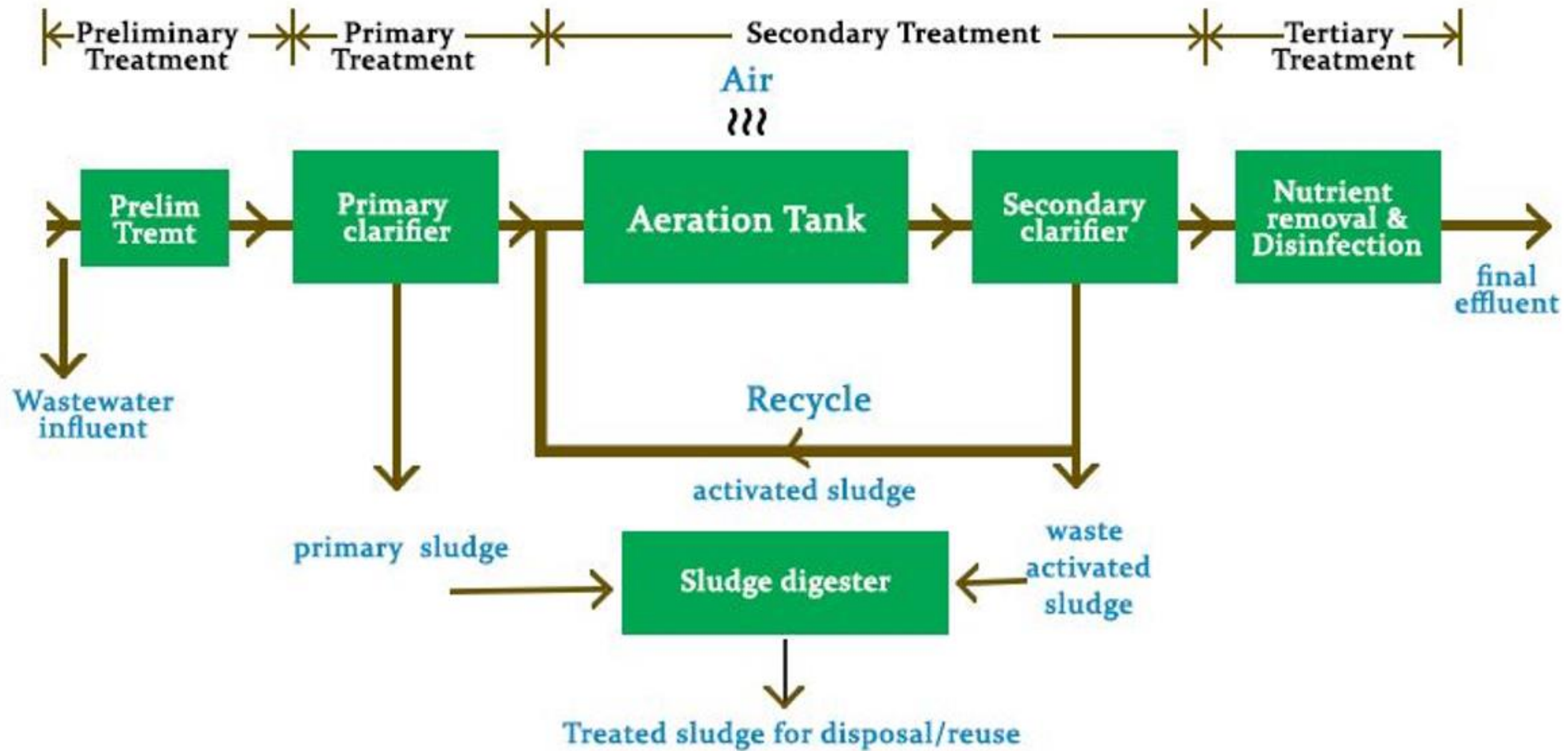

Wastewater treatment chemical unit processes

- Treatment methods in which change is brought by means or through chemical reactions.
- Chemical unit processes are used in conjunction with the physical unit operations.
- The principle chemical units used for wastewater include :

Chemical coagulation, chemical precipitation, chemical disinfection, chemical oxidation, ion exchange

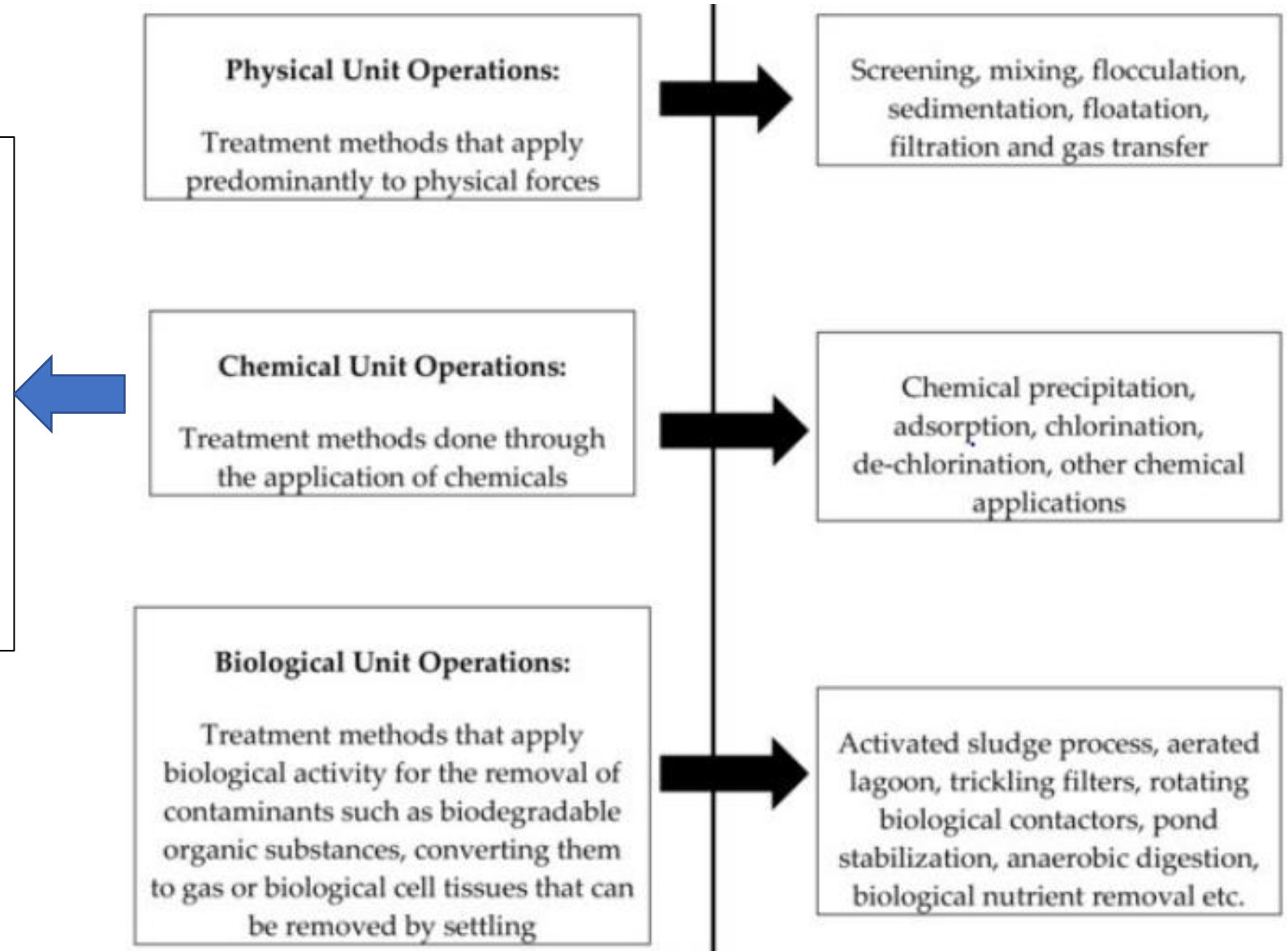

Size of particles found in source water

Particle/Material	Particle Diameter (μm)
Viruses	0.005 - 0.01
Bacteria	0.3 - 3.0
Small colloids	0.001 - 0.1
Large colloids	0.1 - 1
Soil	1 - 100
Sand	500
Floc particles	100 - 2,000

- ❑ > 1 mm will usually settle in quiescent water
- ❑ smaller particles will not settle readily
- ❑ suspension of particles that will not settle is known as a stable suspension
- ❑ particles = colloids

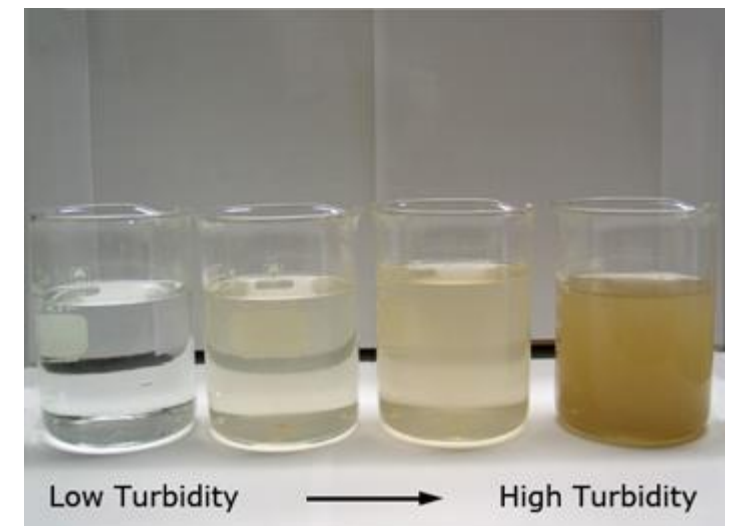

Why do particles remain in suspension?

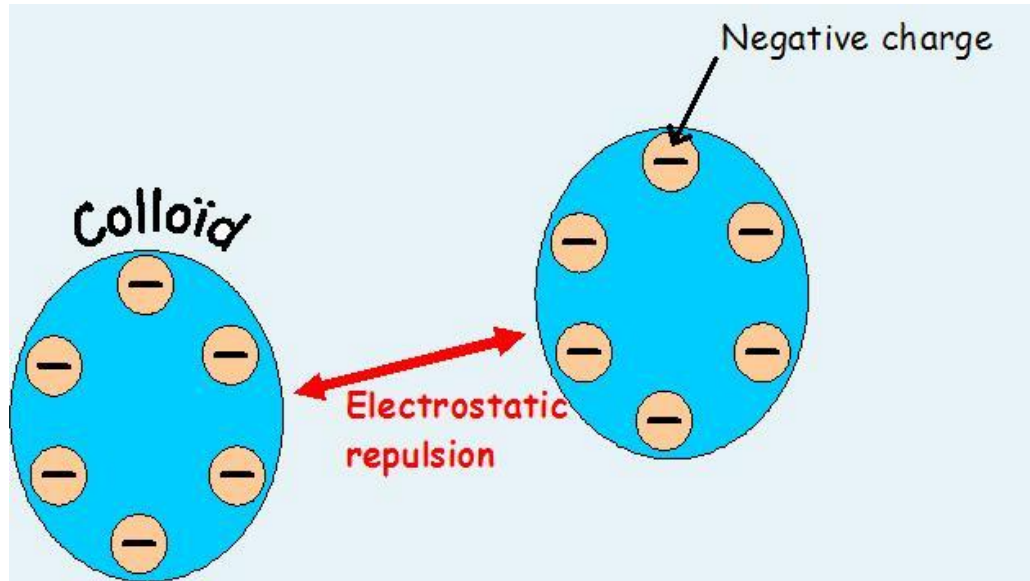

Electrostatic force

- Many of the contaminants in water and wastewater contain matter in the colloidal form.
- These colloids result in a **stable** "suspension".
- In general the suspension is stable enough so that **gravity forces will not cause precipitation** of these colloidal particles.
- So they need special treatment to remove them from the aqueous phase. This **destabilization** of colloids is called "coagulation".

Surface phenomena

Electrostatic force

- Principal force contributing to stability of suspension.
- Electrically charged particles.

- Van del Waals force

- Attraction between any two masses.
- Opposing force to electrostatic forces.

- Brownian motion

- Insignificant

Goal → reduce magnitude of electrostatic forces

Forces Acting on Colloids

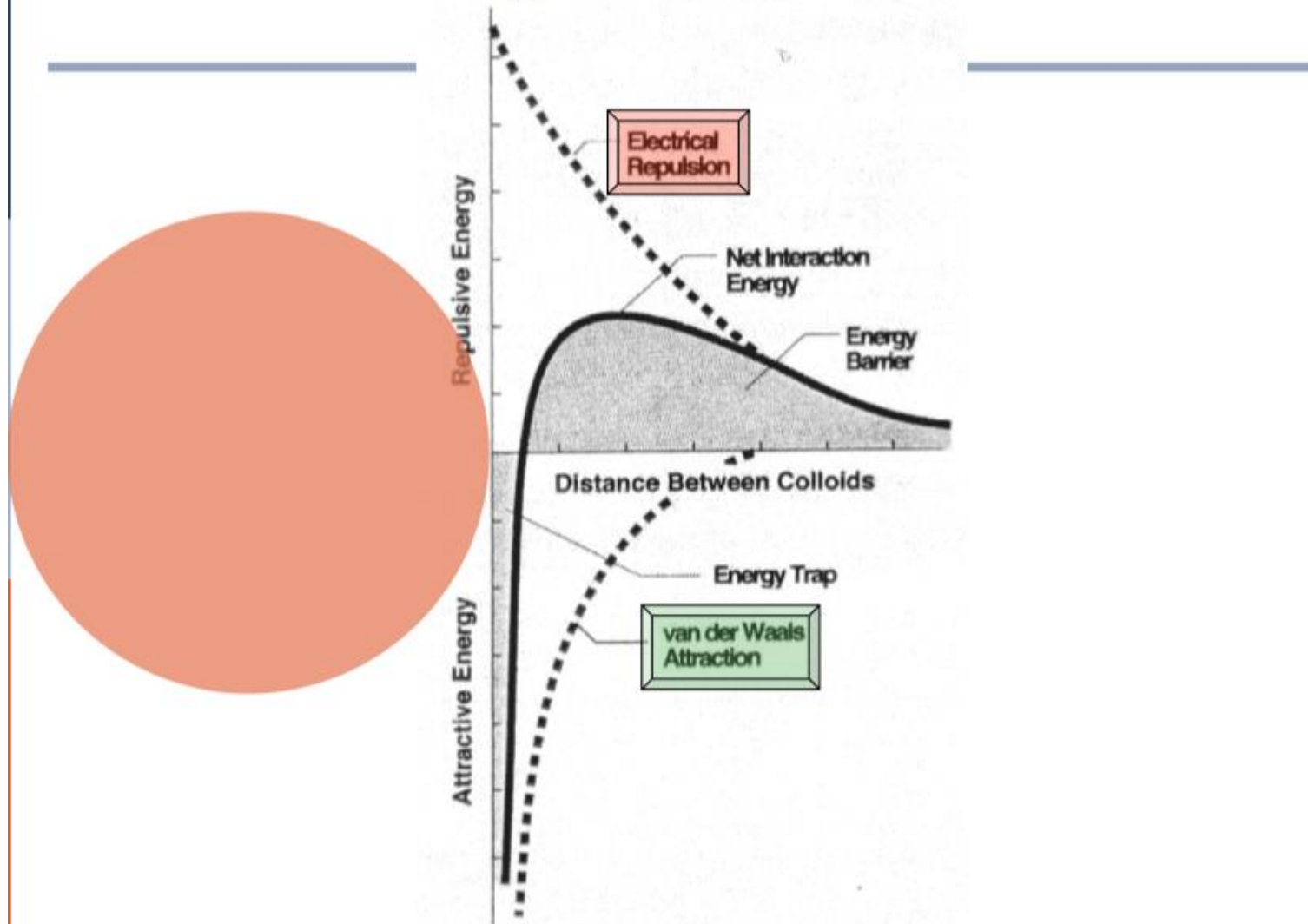

Coagulation

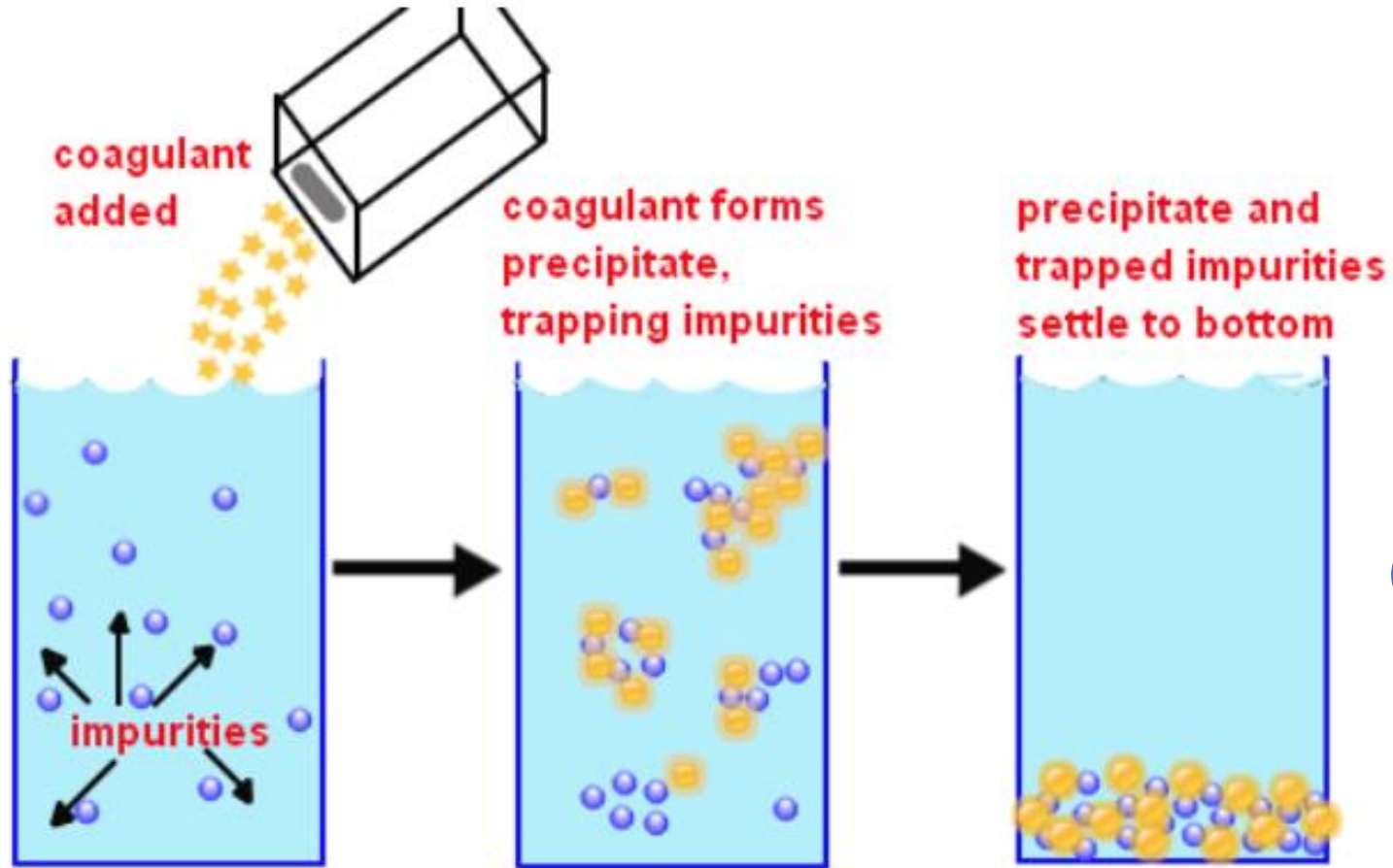

The process of destabilization colloidal particles.

Coagulants

aluminum sulfate (alum)

ferric sulfate

ferric chloride

ferrous sulfate

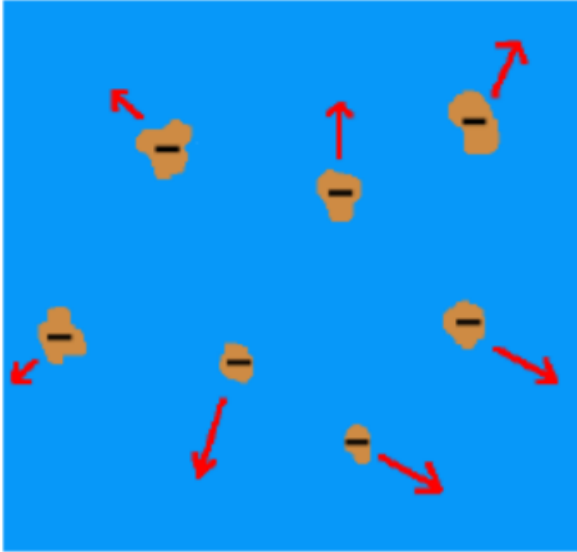

Negatively charged particles need to be removed.

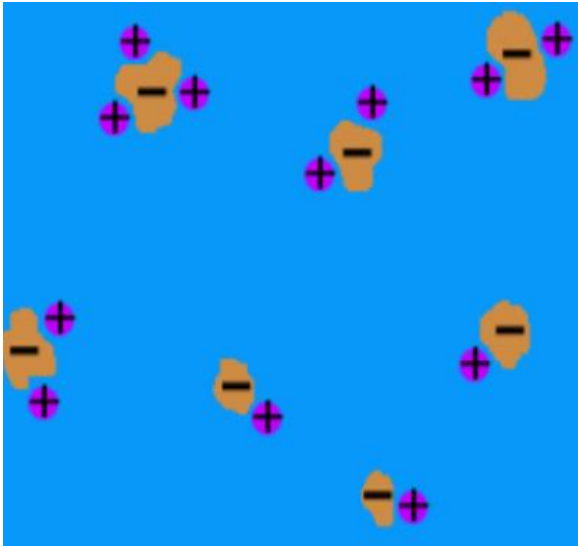

Due to their positive charges, they are attracted to the negatively charged particles.

Like charges repel each other, while opposite charges attract.

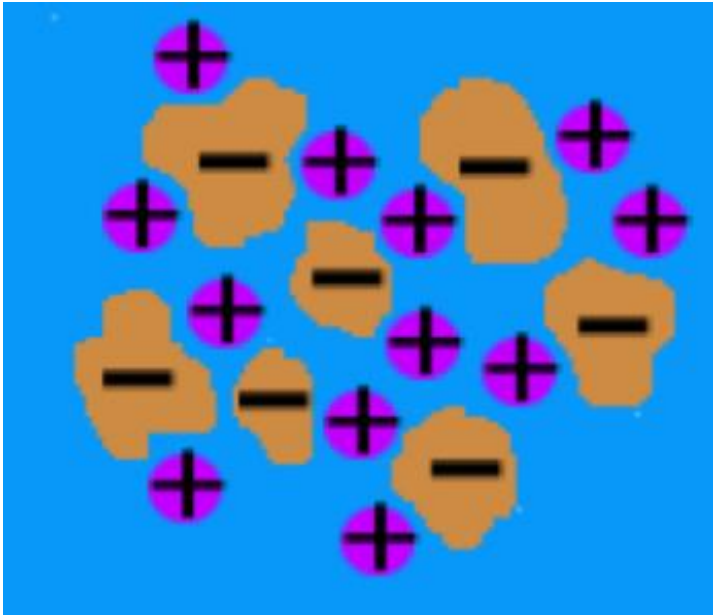
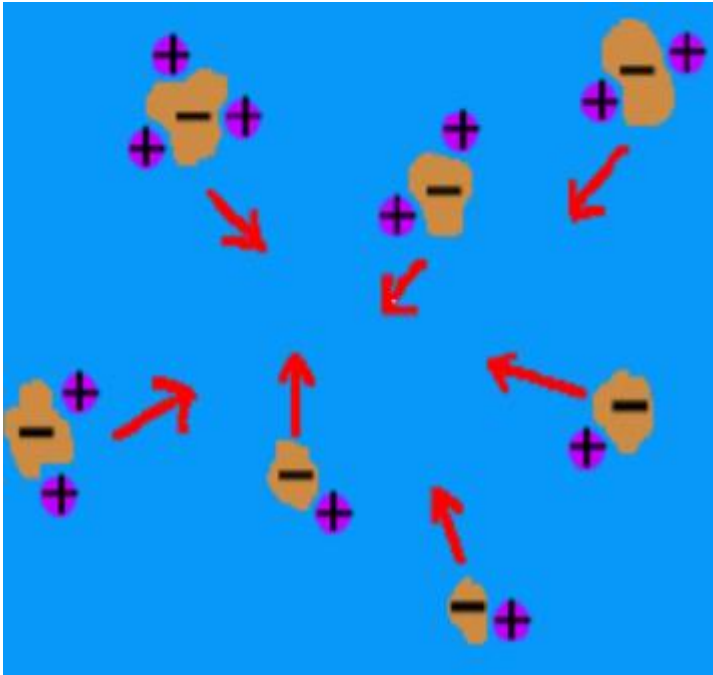

The combination of positive and negative charges result in neutral, or lack of charge.

Design of Coagulation processes

- The design of coagulation process involves:
- (1) selection of proper coagulant chemicals and their dosages.
- (2) design of rapid-mix and flocculation basins.

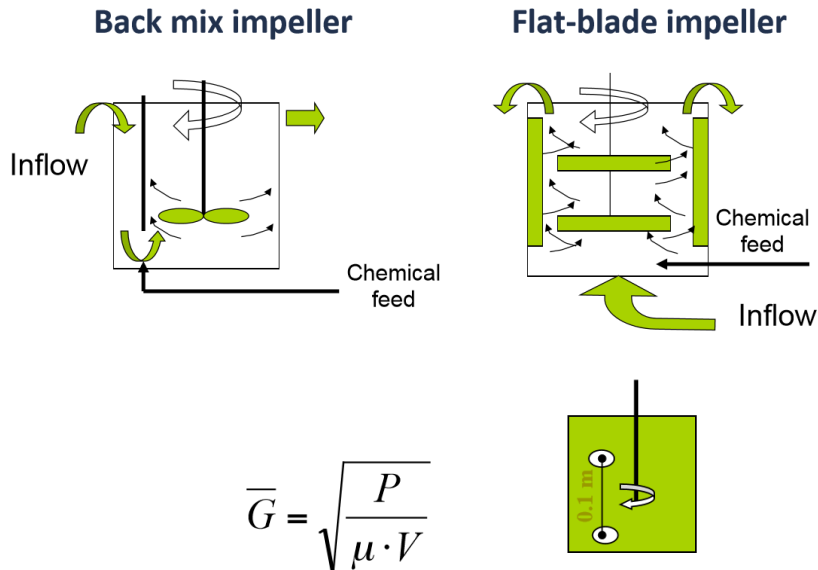
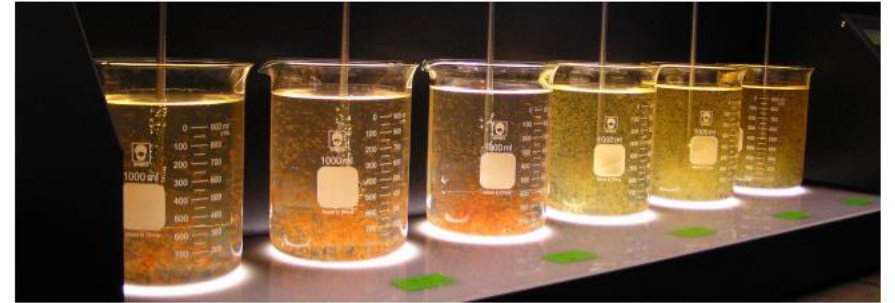

$$\bar{G} = \sqrt{\frac{P}{\mu \cdot V}}$$

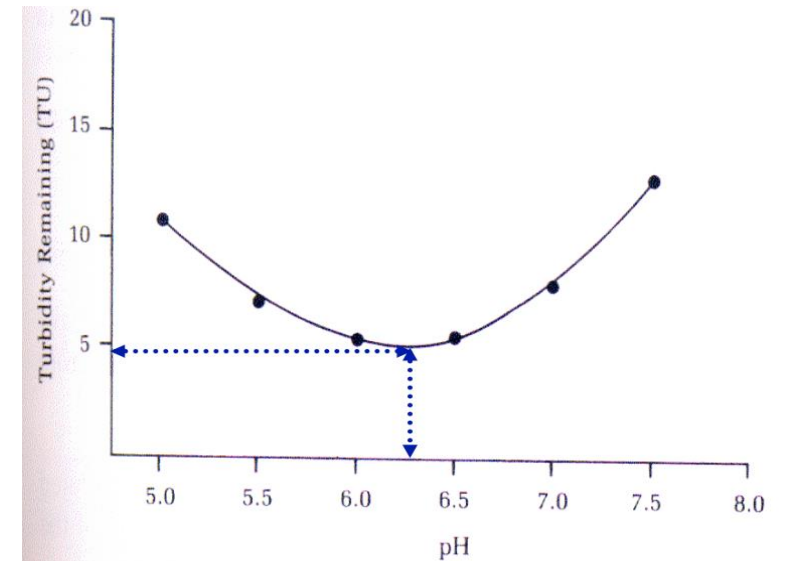
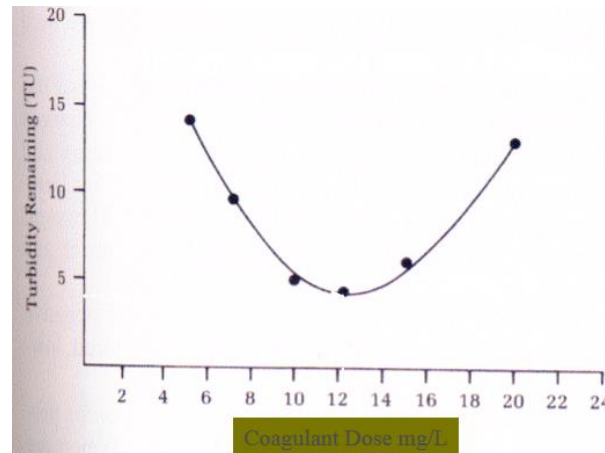

Aqueous chemistry of iron and aluminum

Ferric sulfate

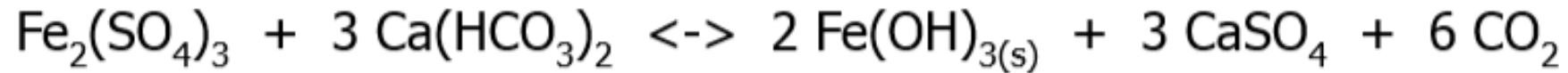

Ferric chloride

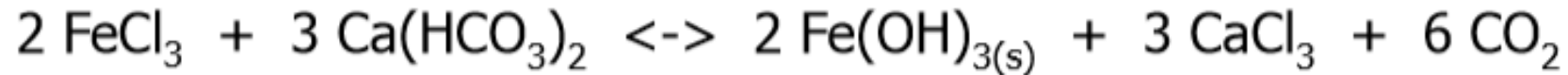

Aluminum sulfate

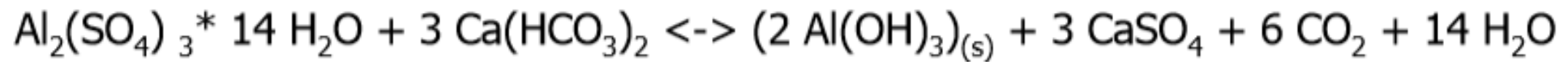

Aluminum chemistry



1 mole of alum consumes 6 moles of bicarbonate (HCO_3^-)

- If alkalinity is not enough, pH will drop due to sulfuric acid formation

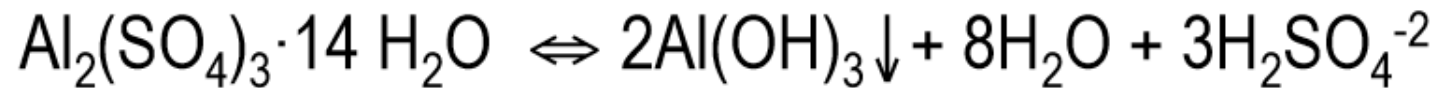

- Lime or sodium carbonate may be needed to neutralize the acid

Maintain Optimal pH range

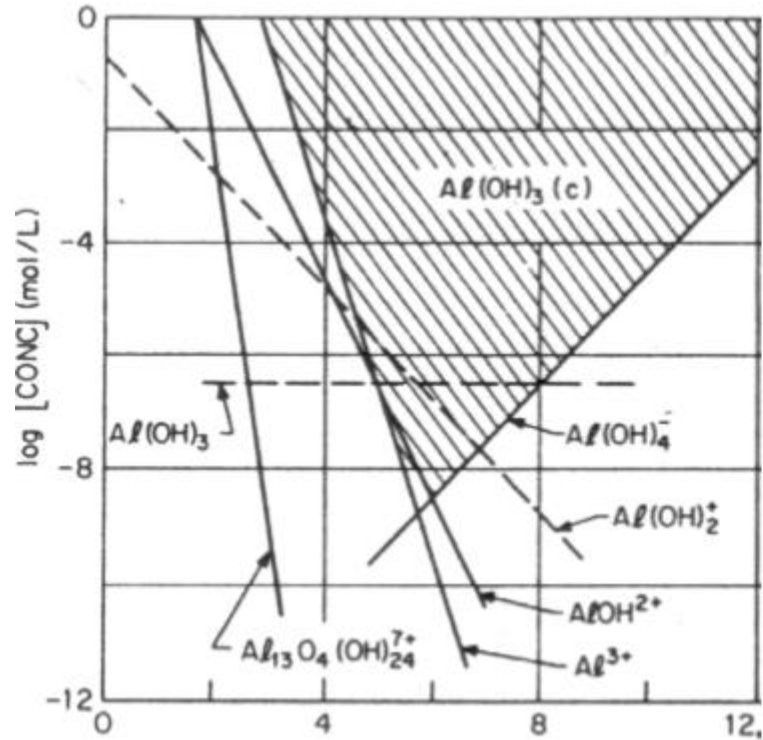

Solubility of aluminum hydroxide

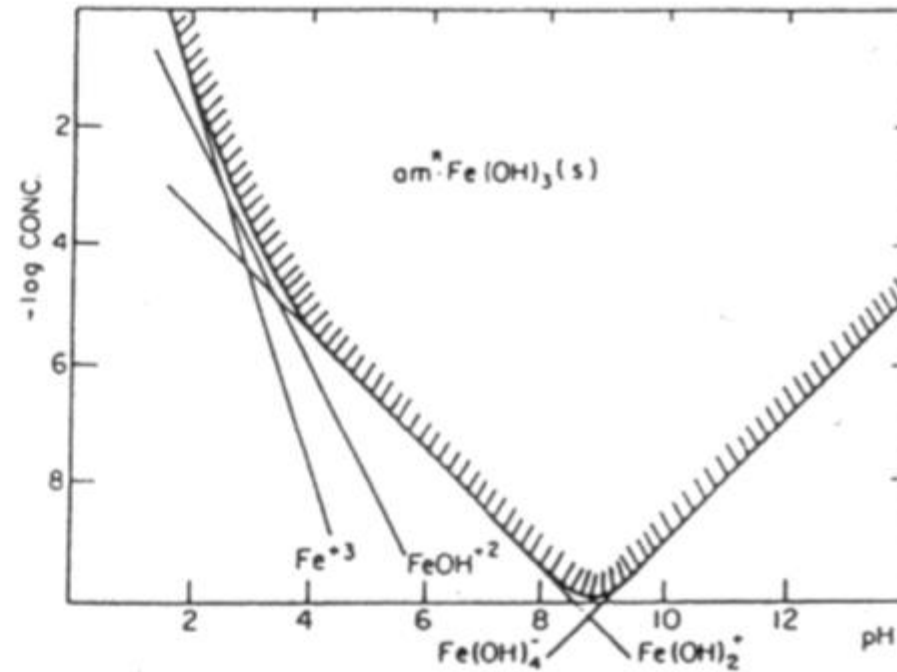

Solubility of iron hydroxide

Determination of optimum pH, coagulant dose

- Jar Test

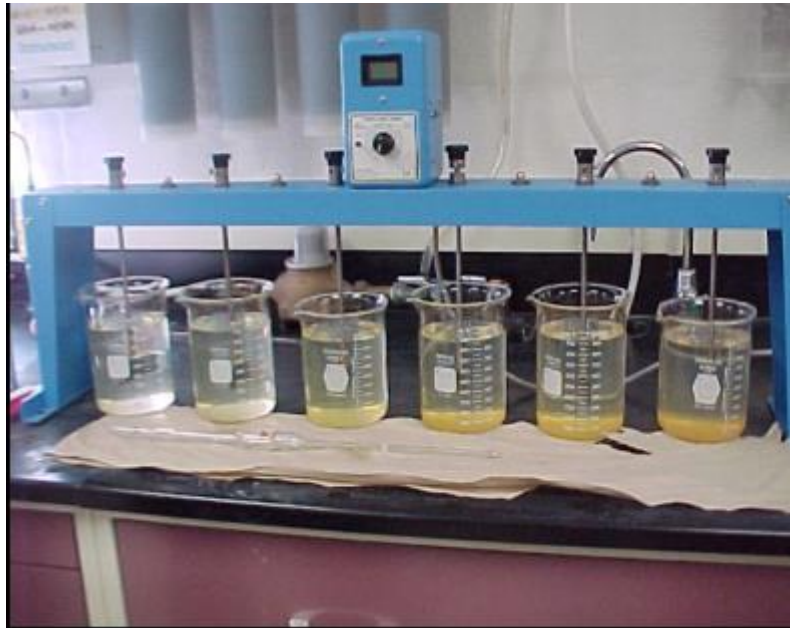

Jar test apparatus

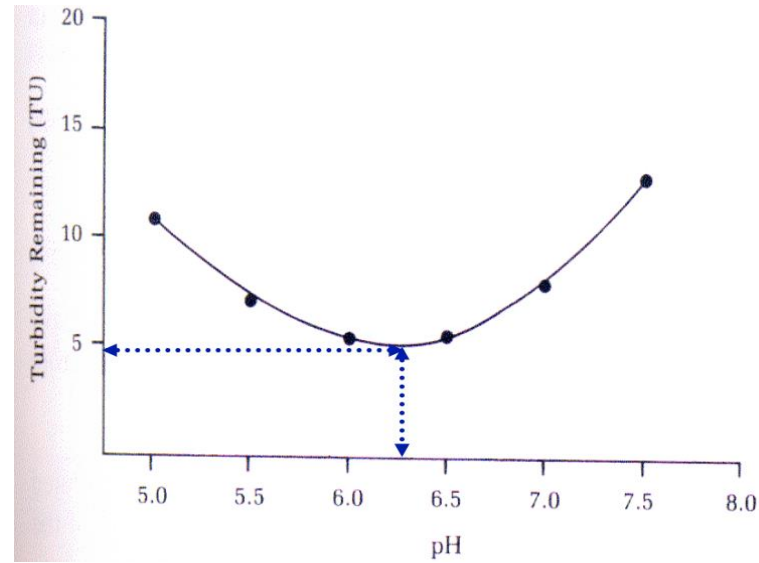

The pH with the lowest residual turbidity is the optimum pH

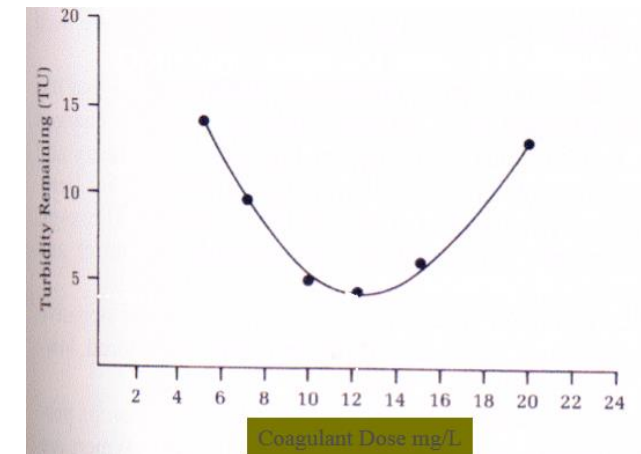

The dose with the lowest residual turbidity is the optimum dose

Jar Tests

- ❑ The jar test – a laboratory procedure to determine the optimum pH and the optimum coagulant dose
- ❑ A jar test simulates the coagulation and flocculation processes

Determination of optimum pH

- ❑ Fill the jars with raw water sample (500 or 1000 mL) – usually 6 jars
- ❑ Adjust pH of the jars while mixing using H_2SO_4 or NaOH /lime (pH: 5.0; 5.5; 6.0; 6.5; 7.0; 7.5)
- ❑ Add same dose of the selected coagulant (alum or iron) to each jar (Coagulant dose: 5 or 10 mg/L)

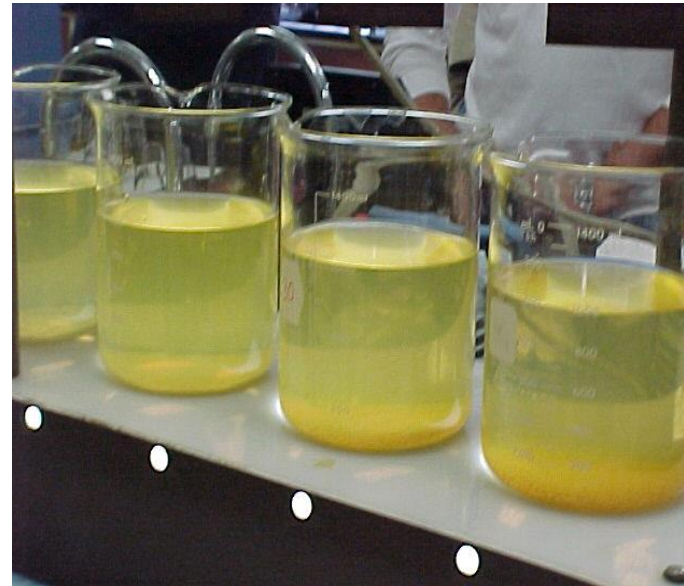

Jar Test

Jar Tests – determining optimum pH

- ❑ Rapid mix each jar at 100 to 150 rpm for 1 minute. The rapid mix helps to disperse the coagulant throughout each container.
- ❑ Reduce the stirring speed to 25 to 30 rpm and continue mixing for 15 to 20 mins
This slower mixing speed helps promote floc formation by enhancing particle collisions, which lead to larger flocs.
- ❑ Turn off the mixers and allow flocs to settle for 30 to 45 mins.
- ❑ Measure the final residual turbidity in each jar.
- ❑ Plot residual turbidity against pH.

Jar Test set-up

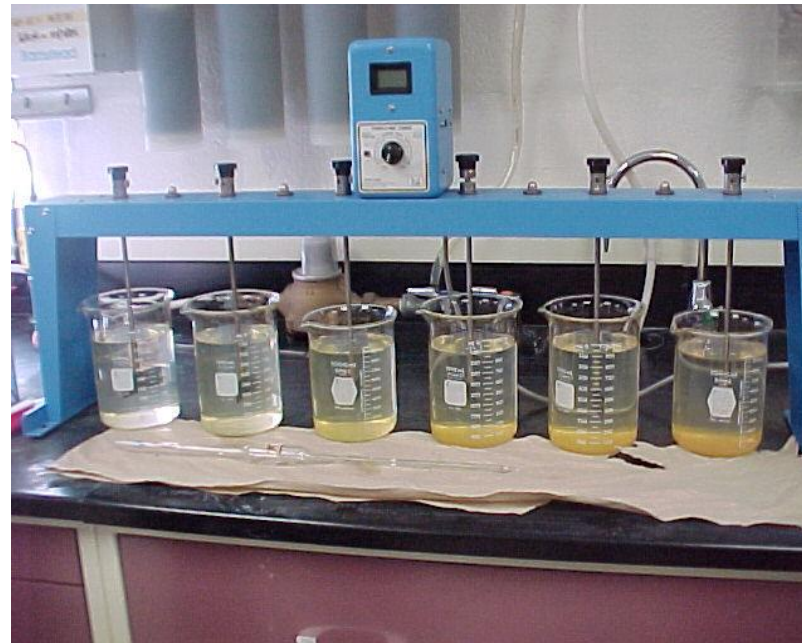

Jar Tests – optimum pH

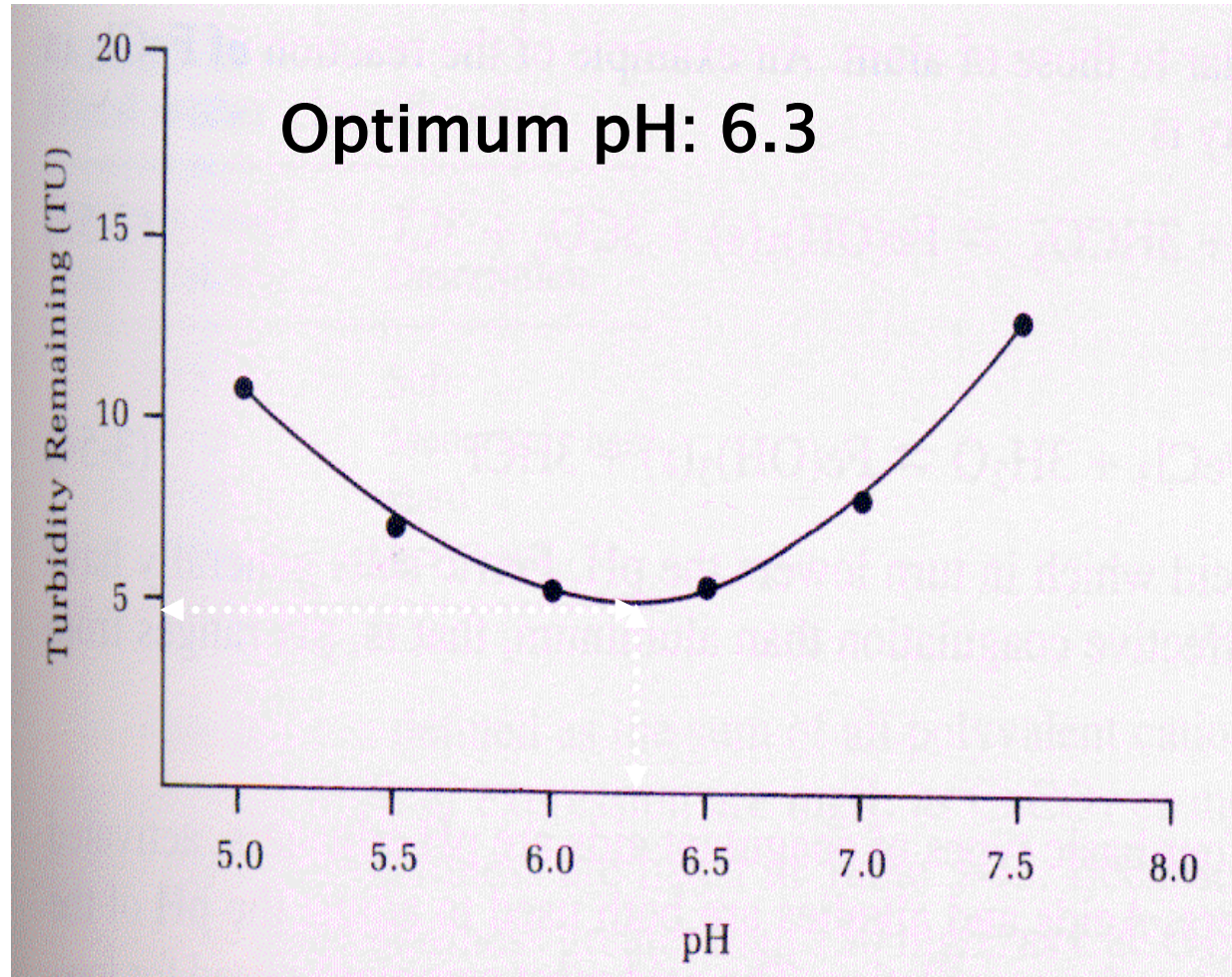

Optimum coagulant dose

- Repeat all the previous steps.
- This time adjust pH of all jars at optimum (6.3 found from first test) while mixing using H_2SO_4 or NaOH /lime.
- Add different doses of the selected coagulant (alum or iron) to each jar (Coagulant dose: 5; 7; 10; 12; 15; 20 mg/L).
- Rapid mix each jar at 100 to 150 rpm for 1 minute. The rapid mix helps to disperse the coagulant throughout each container.
- Reduce the stirring speed to 25 to 30 rpm for 15 to 20 mins.

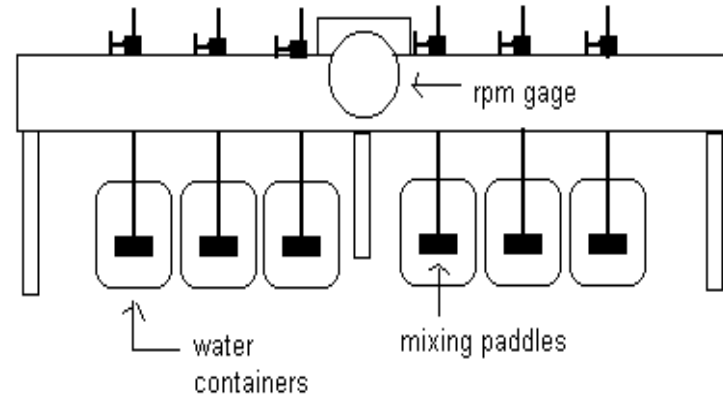

Optimum coagulant dose

- ❑ Turn off the mixers and allow flocs to settle for 30 to 45 min.
- ❑ Then measure the final residual turbidity in each jar.
- ❑ Plot residual turbidity against coagulant dose.

The coagulant dose with the lowest residual turbidity will be the optimum coagulant dose.

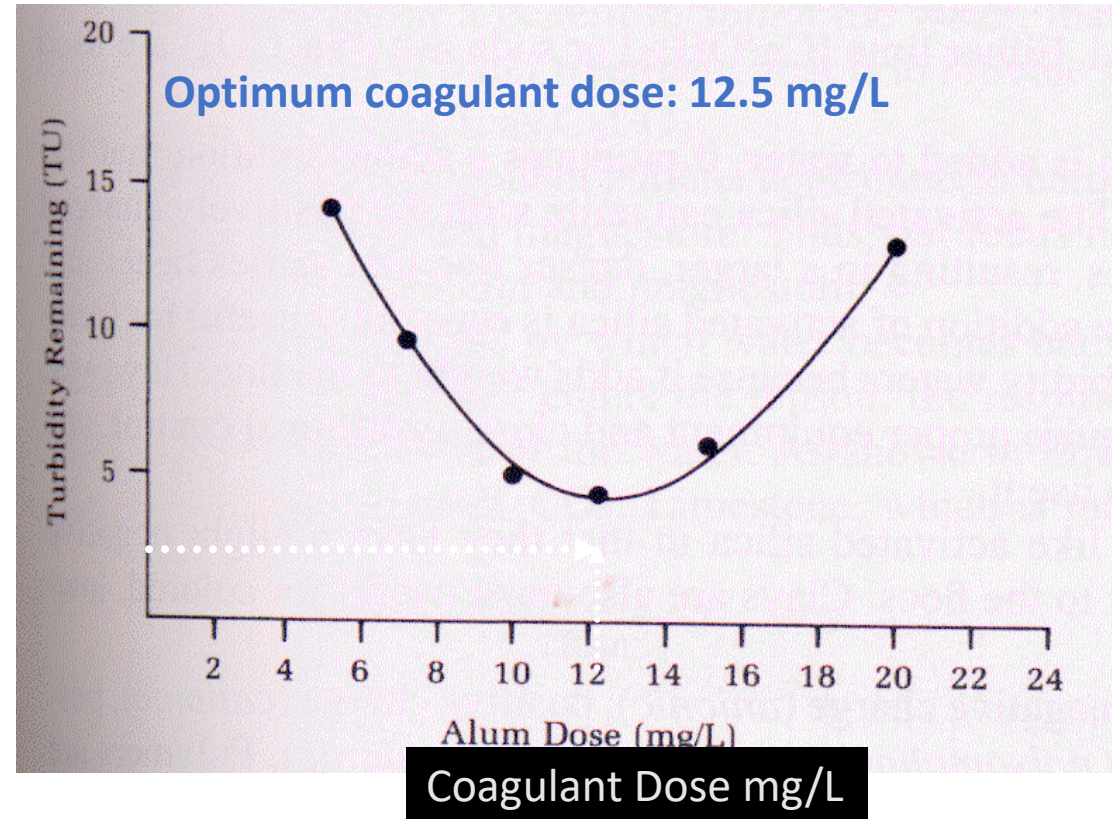

Rapid Mixing

Provide sufficient agitation to disperse the coagulant or softening chemicals homogeneously

□ Design Considerations:

- design for short period of vigorous agitation
- chemicals being added at the point of greatest turbulence

□ Types of Mixers

- Static mixer
- Pumped flash mixer
- Mechanically agitated mixer

How to achieve rapid mixing?

Horizontal baffled tank

The water flows in horizontal direction. The baffle walls help creating turbulence when the water hit the surface and thus facilitate mixing

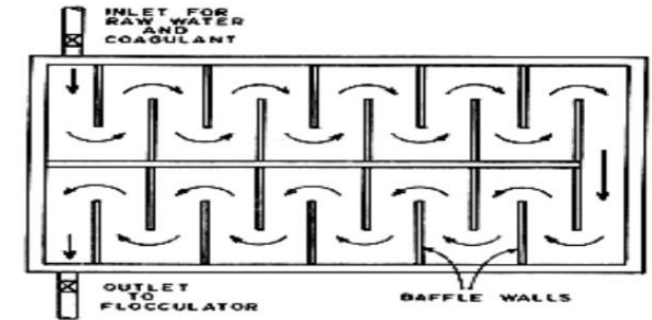
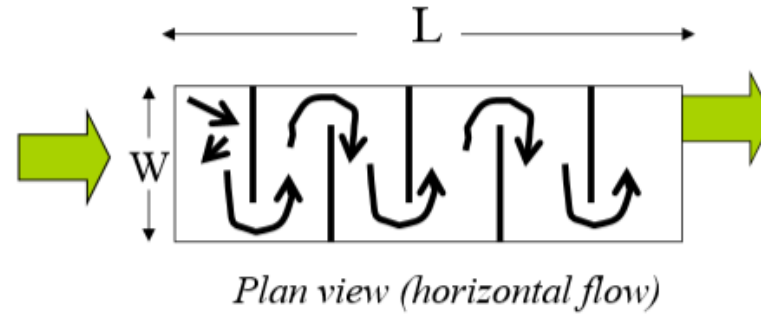

Vertical baffled tank

The water flows in vertical directions

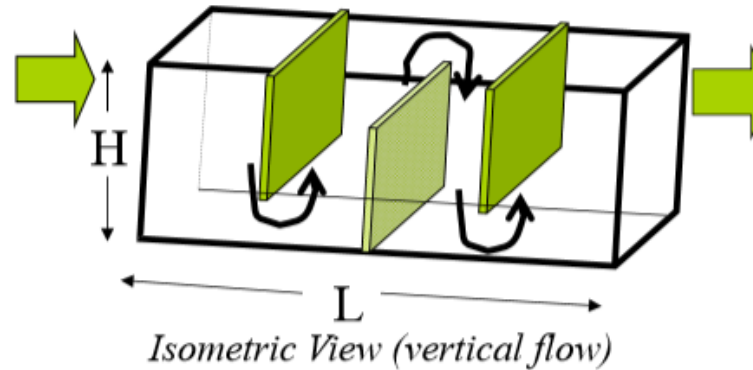

Mechanical mixing

Back mix impeller

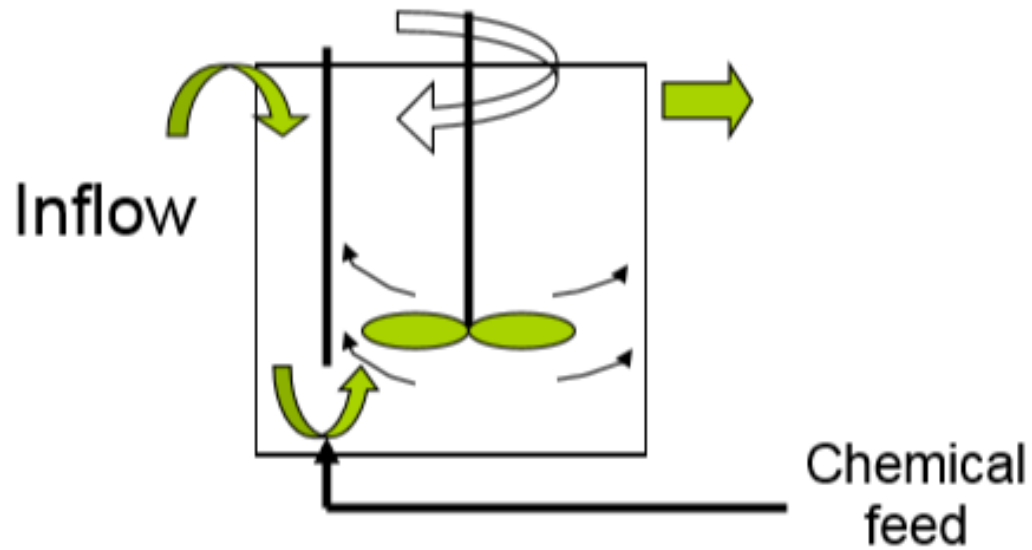

Flat-blade impeller

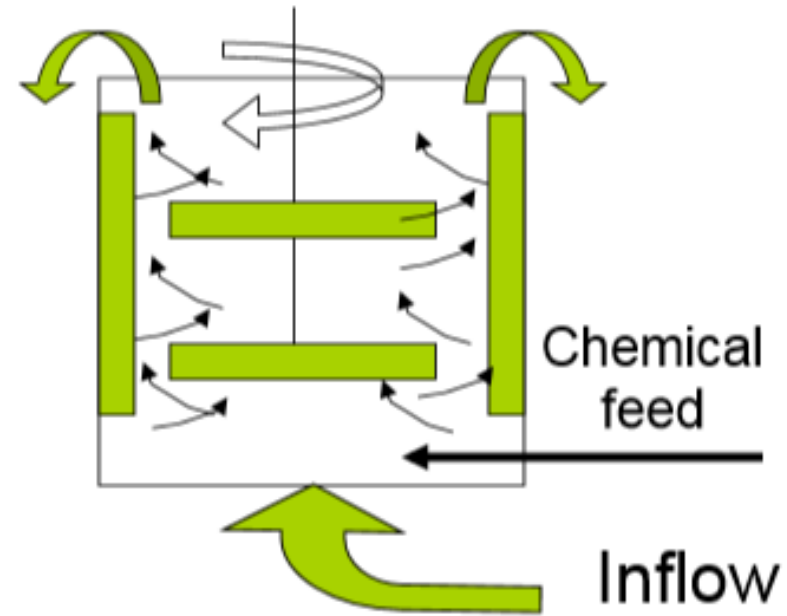

Mixing and power

- ❑ The degree of mixing is measured by **Velocity Gradient (G)**
- ❑ Higher G value → more intense mixing
- ❑ Velocity Gradient is the relative velocity of two fluid particles at a given distance

$$G = dv/dy = 1.0/0.1 = 10 \text{ sec}^{-1}$$

- ❑ In mixer design, the following equation is used:

$$\bar{G} = \sqrt{\frac{P}{\mu \cdot V}}$$

G = velocity gradient, sec^{-1} ;

V = Tank volume, m^3 ;

P = Power input, Watt (J/sec)

μ = Dynamic viscosity (Pa·sec)

μ unit: $1 \text{ Pa}\cdot\text{s} = 1 \text{ N s/m}^2 = 1 \text{ kg/m}\cdot\text{s}$

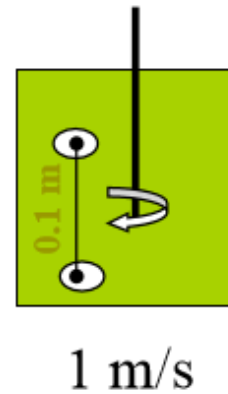

Mixing and power

- Viscosity as a function of temperature

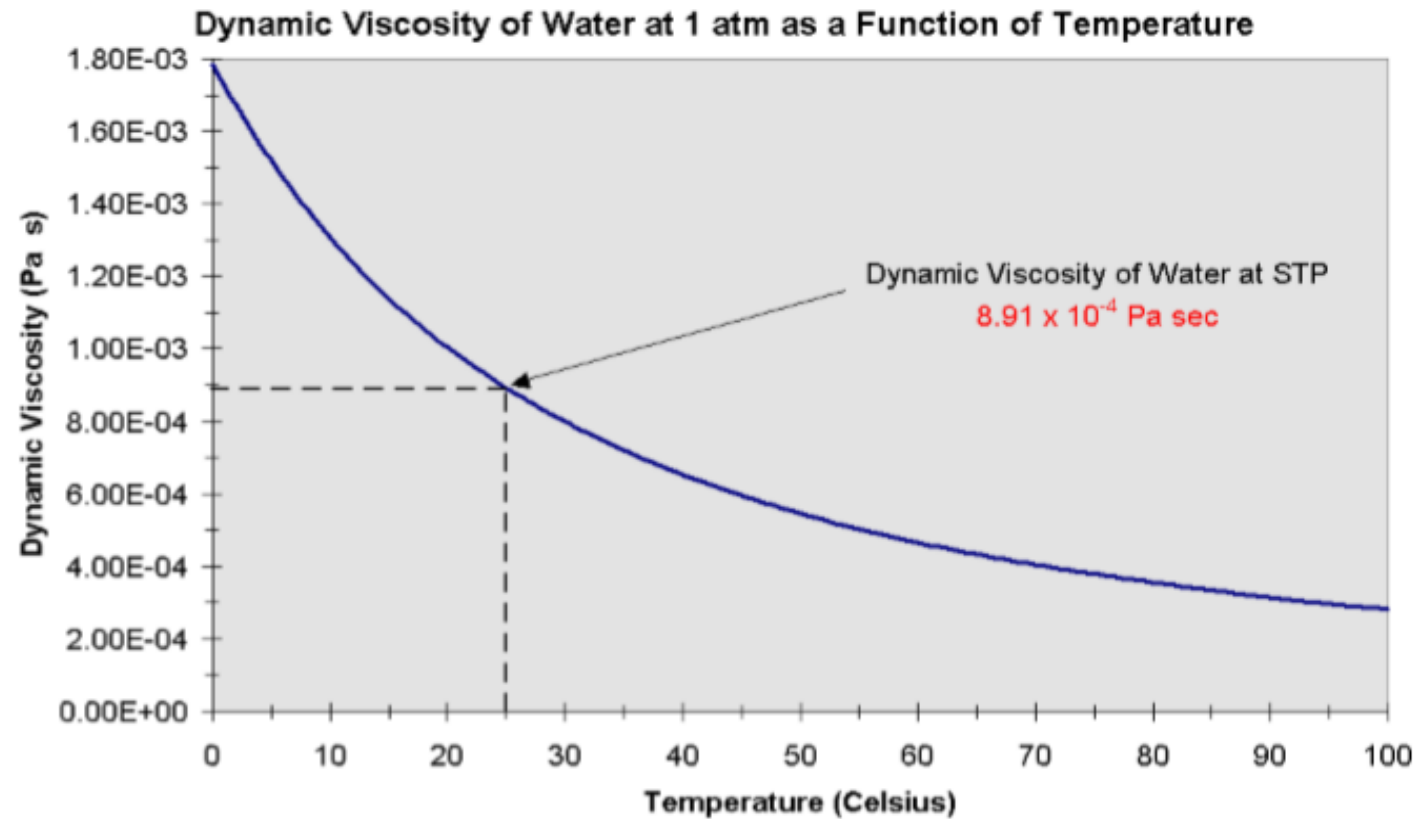

Rapid Mixing

- ❑ Total number of particle collisions is proportional to the product of G and the time t
- ❑ Effective Gt values for flash mixing:
 - General value 300 – 1,600
 - Adsorption-destabilization:
 - ❑ $t < 1$ second, recommended 0.5 second
 - ❑ $G = 3000 - 5,000 \text{ s}^{-1}$
 - Sweep floc coagulation
 - ❑ Occurs slower, t in the range of 1-10 second
 - ❑ $G = 600 - 1,000 \text{ s}^{-1}$
 - Removal of color and NOM
 - ❑ Occurs slower, t in the range of 2-5 minutes
 - ❑ $G = 300 - 700 \text{ s}^{-1}$

Example

The design flow for a water treatment plant (WTP) is 1 MGD ($3.8 \times 10^3 \text{ m}^3/\text{d}$). The rapid mixing tank will have a mechanical mixer and the average alum dosage will be 30 mg/L. The theoretical mean hydraulic detention time of the tank will be 1 minute. Determine the following:

- the quantity of alum needed on a daily basis in kg/d,
- the dimensions of the tank in meters for a tank with equal length, width, and depth,
- the power input required for a G of 900 sec^{-1} for a water temperature of 10°C –

- a) the quantity of alum needed on a daily basis in kg/d,

$$\begin{aligned} \text{amount needed} &= Q \times \text{dose} \\ &= 3.8 \times 10^3 \frac{\text{m}^3}{\text{d}} \times 30 \frac{\text{mg}}{\text{L}} \left\{ \frac{1 \text{Kg}}{10^6 \text{mg}} \frac{1000 \text{L}}{\text{m}^3} \right\} \\ &= 114 \frac{\text{Kg}}{\text{d}} \end{aligned}$$

$$\text{amount needed} = 114 \frac{\text{Kg}}{\text{d}}$$

b) the dimensions of the tank in meters for a tank with equal length, width, and depth,

$$\begin{aligned} V &= Qt_R \\ &= 3.8 \times 10^3 \frac{m^3}{d} \times 1 \text{min} \left\{ \frac{1d}{1440 \text{min}} \right\} \\ &= 2.64 m^3 \end{aligned}$$

$$V = L \times W \times H = 2.64 m^3$$

For a tank of equal length, width and height, $L=W=H$, so:

$$\begin{aligned} V &= x^3 = 2.64 m^3 \\ x &= 1.4 m \end{aligned}$$

$$\text{Length} = \text{Width} = \text{Depth} = 1.4 m$$

c)

$$G = \left(\frac{P}{\mu V} \right)^{0.5}$$

So

$$P = \mu V G^2 = 1.307 \times 10^{-3} \frac{Kg}{m-s} 2.64 m^3 (900 s)^2 = 2795 \frac{Kg-m^2}{s^3} = 2.8 kW$$

Note that:

$$\frac{Kg-m^2}{s^3} = \frac{Kg-m}{s^2} \left(\frac{m}{s} \right) = N \frac{m}{s} = \frac{J}{s} = W$$

Wastewater Engineering

Disinfection

3.75 million

people die every year
from waterborne diseases



Water Related Diseases and Their Causes

Diseases

- Diarrhea
- Arsenicosis
- Fluorosis
- Schistosomiasis
- Intestinal Worms
- Guinea Worm
- Hepatitis
- Cholera
- Malaria
- Trachoma
- Typhoid

Bacteria

- E. coli*
- Salmonella typhi*
- Shigella spp.*
- Yersinia enterocolitica*



Viruses

- Hepatitis A/E virus
- Adenovirus
- Enterovirus
- Rotavirus

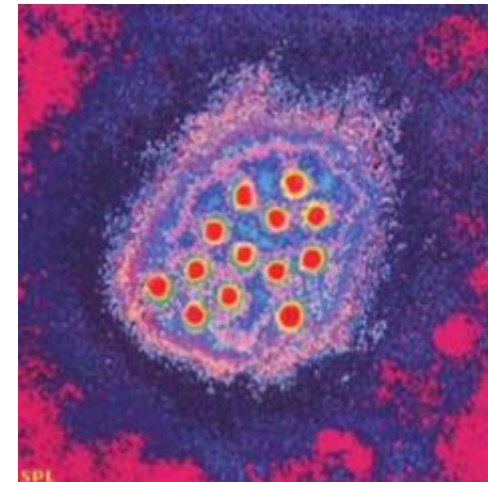

Disinfection

- Any process to destroy or prevent the growth of microbes.
- Intended to inactivate the microbes by physical, chemical or biological processes.
- Inactivation is achieved by altering or destroying essential structures or functions within the microbe
- Inactivation processes include denaturation of:
 - proteins (structural proteins, transport proteins, enzymes).
 - nucleic acids (genomic DNA or RNA, mRNA, tRNA, etc.).
 - lipids (lipid bilayer membranes, other lipids).

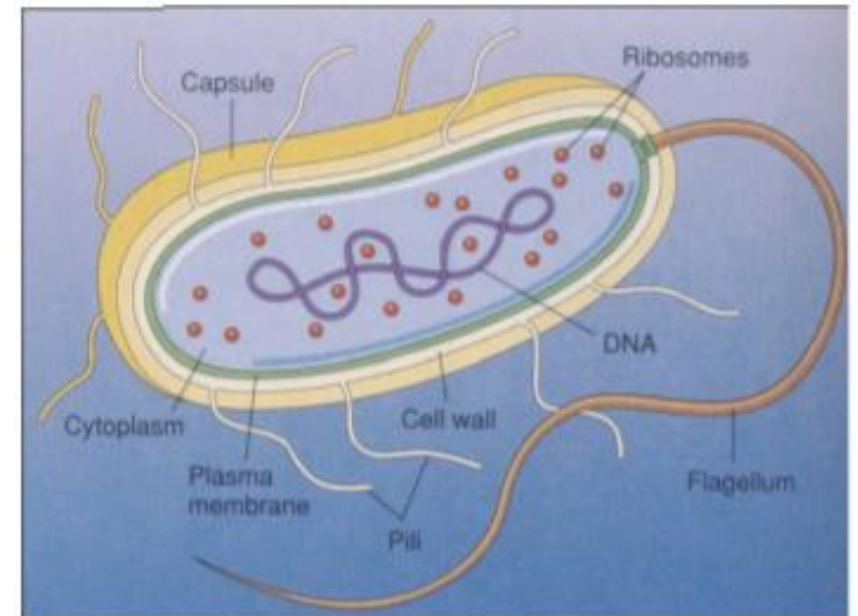
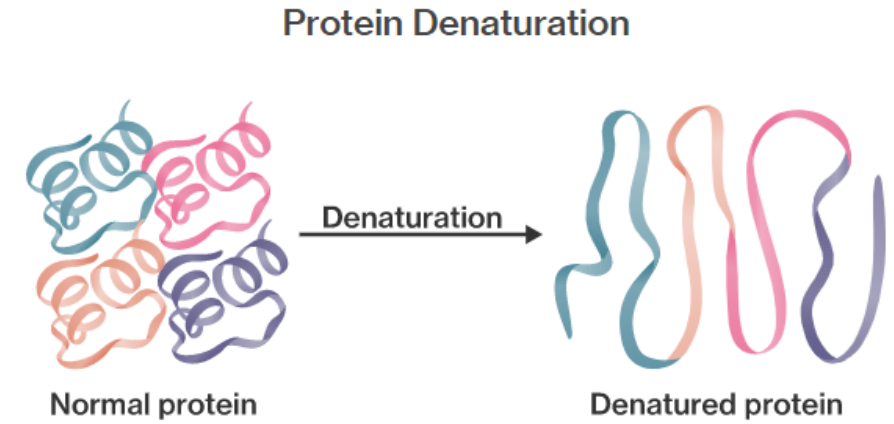

Properties of an Ideal Disinfectant



- Broad spectrum: active against all microbes: Versatile.
- Fast acting: produces rapid inactivation.
- Effective in the presence of organic matter, suspended solids and other matrix or sample constituents.
- Nontoxic; soluble; non -flammable; non –explosive.
- Compatible with various materials/surfaces.
- Stable or persistent for the intended exposure period.
- Provides a residual (sometimes this is undesirable).
- Easy to generate and apply.
- Economical.

Disinfectants in water and wastewater treatment

- Free chlorine.
 - Chloramines (Monochloramine).
 - Ozone.
 - Chlorine dioxide.
 - Mixed oxidants.
 - UV irradiation.
- Concerns due to health risks of chemical disinfectants and their by-products (DBPs), especially free chlorine and its DBPs.

Comparison of major disinfectants

Consideration	Disinfectants			
	Cl_2	ClO_2	O_3	NH_2Cl
Oxidation potential	Strong	Stronger?	Strongest	Weak
Residuals	Yes	No	No	Yes
Mode of action	Proteins/NA	Proteins/NA	Proteins/NA	Proteins
Disinfecting efficacy	Good	Very good	Excellent	Moderate
By-products	Yes	Yes	Yes	No

	Reduction Half-Reaction	E° (V)	
 <p>Stronger oxidizing agent</p>	$F_2(g) + 2 e^- \longrightarrow 2 F^-(aq)$	2.87	 <p>Weaker reducing agent</p>
	$H_2O_2(aq) + 2 H^+(aq) + 2 e^- \longrightarrow 2 H_2O(l)$	1.78	
	$MnO_4^-(aq) + 8 H^+(aq) + 5 e^- \longrightarrow Mn^{2+}(aq) + 4 H_2O(l)$	1.51	
	$Cl_2(g) + 2 e^- \longrightarrow 2 Cl^-(aq)$	1.36	
	$Cr_2O_7^{2-}(aq) + 14 H^+(aq) + 6 e^- \longrightarrow 2 Cr^{3+}(aq) + 7 H_2O(l)$	1.33	
	$O_2(g) + 4 H^+(aq) + 4 e^- \longrightarrow 2 H_2O(l)$	1.23	
	$Br_2(l) + 2 e^- \longrightarrow 2 Br^-(aq)$	1.09	
	$Ag^+(aq) + e^- \longrightarrow Ag(s)$	0.80	
	$Fe^{3+}(aq) + e^- \longrightarrow Fe^{2+}(aq)$	0.77	
	$O_2(g) + 2 H^+(aq) + 2 e^- \longrightarrow H_2O_2(aq)$	0.70	
	$I_2(s) + 2 e^- \longrightarrow 2 I^-(aq)$	0.54	
	$O_2(g) + 2 H_2O(l) + 4 e^- \longrightarrow 4 OH^-(aq)$	0.40	
	$Cu^{2+}(aq) + 2 e^- \longrightarrow Cu(s)$	0.34	
	$Sn^{4+}(aq) + 2 e^- \longrightarrow Sn^{2+}(aq)$	0.15	
	$2 H^+(aq) + 2 e^- \longrightarrow H_2(g)$	0	
	$Pb^{2+}(aq) + 2 e^- \longrightarrow Pb(s)$	-0.13	
	$Ni^{2+}(aq) + 2 e^- \longrightarrow Ni(s)$	-0.26	
$Cd^{2+}(aq) + 2 e^- \longrightarrow Cd(s)$	-0.40		
$Fe^{2+}(aq) + 2 e^- \longrightarrow Fe(s)$	-0.45		
$Zn^{2+}(aq) + 2 e^- \longrightarrow Zn(s)$	-0.76		
$2 H_2O(l) + 2 e^- \longrightarrow H_2(g) + 2 OH^-(aq)$	-0.83		
$Al^{3+}(aq) + 3 e^- \longrightarrow Al(s)$	-1.66		
$Mg^{2+}(aq) + 2 e^- \longrightarrow Mg(s)$	-2.37		
$Na^+(aq) + e^- \longrightarrow Na(s)$	-2.71		
$Li^+(aq) + e^- \longrightarrow Li(s)$	-3.04		
<p>Weaker oxidizing agent</p>			<p>Stronger reducing agent</p>

Chlorine

Chlorine is one of the most widely used disinfectants.

It is very applicable and very effective for the deactivation of pathogenic microorganisms.

Chlorine can be easily applied, measures and controlled. It is relatively cheap.

However, we only started using it as a disinfectants on a wider scale in the nineteenth century, after Louis Pasteur discovered that microorganisms spread certain diseases.



Chlorine

Chlorine demand is the amount of chlorine required to kill bacteria, oxidize iron or other elements in the water.

Free available chlorine residual is the amount of chlorine remaining in the water after the chlorine demand has been met.

Contact time is the amount of time that the chlorine is present in the water. The combination of chlorine residual and contact time determines the effectiveness of the chlorination treatment.

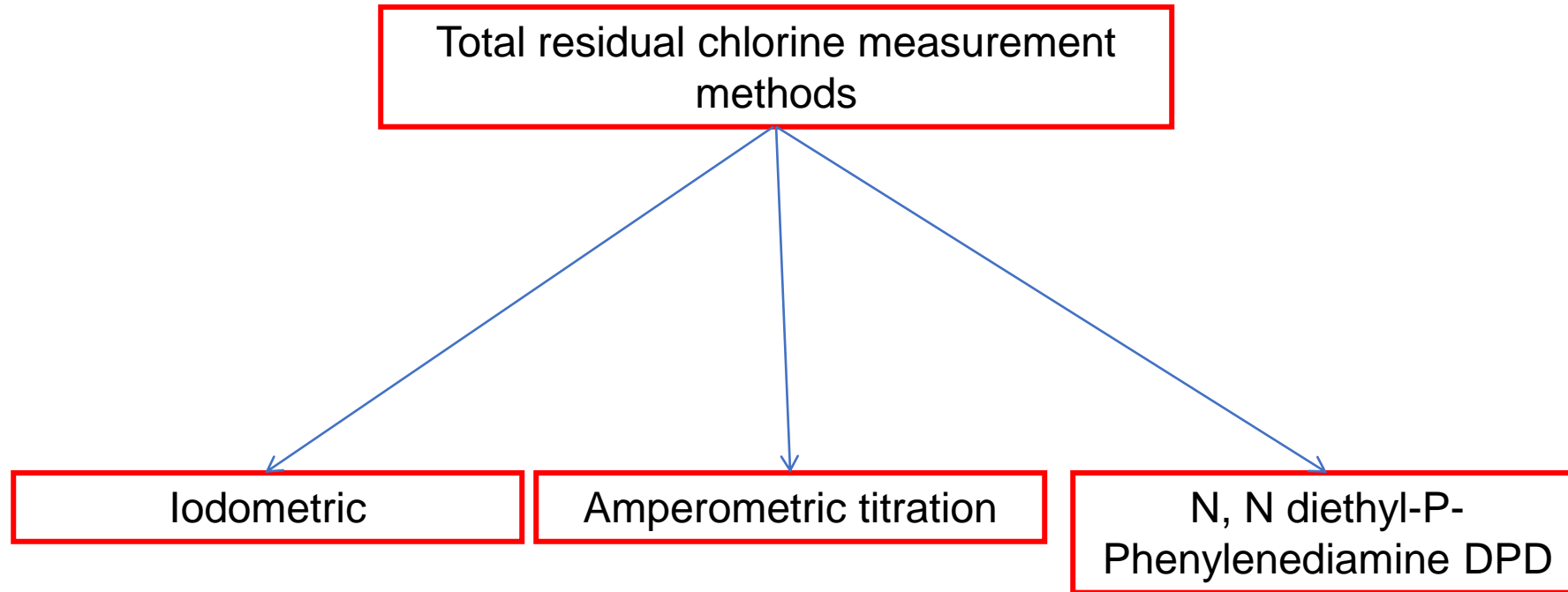

Environmental significance: active chlorine (free and combined) should be determined at each stage in the treatment process of drinking water and in the water mains in order to guarantee bacteriological impeccable water.

Free chlorine

- First used in 1905 in London, in Bubbly Creek in Chicago (in USA) in 1908
 - followed by dramatic reduction of waterborne disease.
 - has been the “disinfectant of choice” in USA until recently.
- being replaced by alternative disinfectants after the discovery of its disinfection by-products (trihalomethanes and other chlorinated organics) during the 1970’s.
 - Recommended maximum residual concentration of free chlorine < 5 mg/L in drinking water (by US EPA)
- Three different methods of application
 - Cl₂ (gas)
 - NaOCl (liquid)
 - Ca(OCl)₂ (solid)

Free chlorine

Chlorine gas hydrolyzation reaction results as hypochlorous acid:



Hypochlorous acid dissociates to hypochlorite ion according to pH:

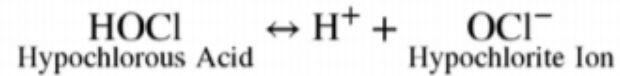

Both hypochlorous acid and hypochlorite are regarded as free chlorine, though hypochlorous acid is more effective disinfectant. In fact, it is the most effective chlorine form.

$$K_a = \frac{[\text{H}^+][\text{OCl}^-]}{[\text{HOCl}]}$$

$$\text{pKa} = 7,6, 20 \text{ }^\circ\text{C}$$

Means that below this pH hypochlorous acid is the predominant form.

Chlorine application (I)

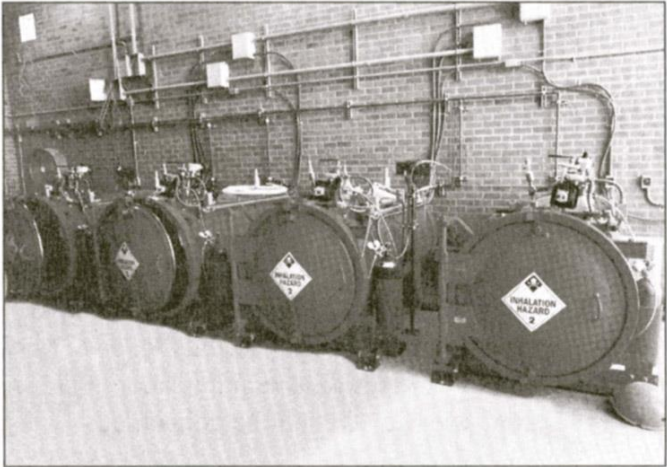
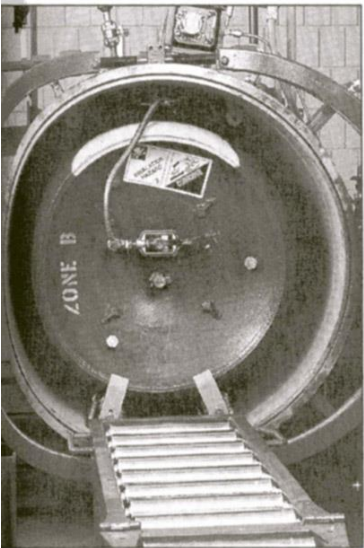
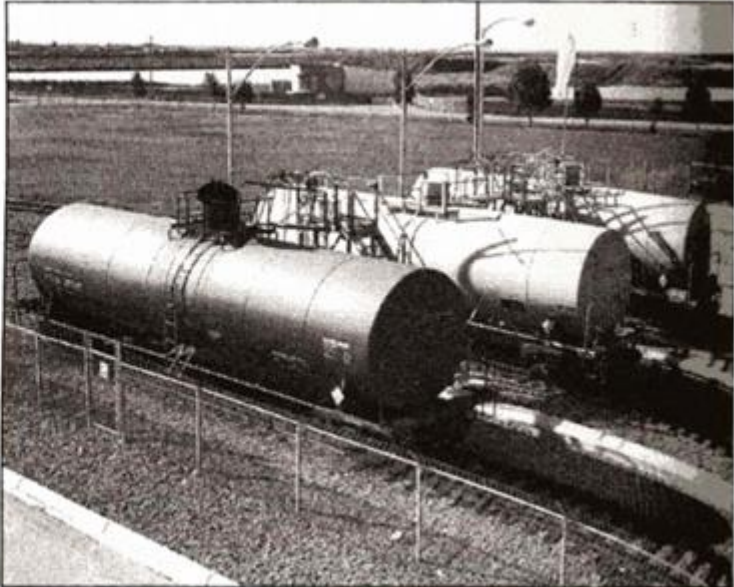
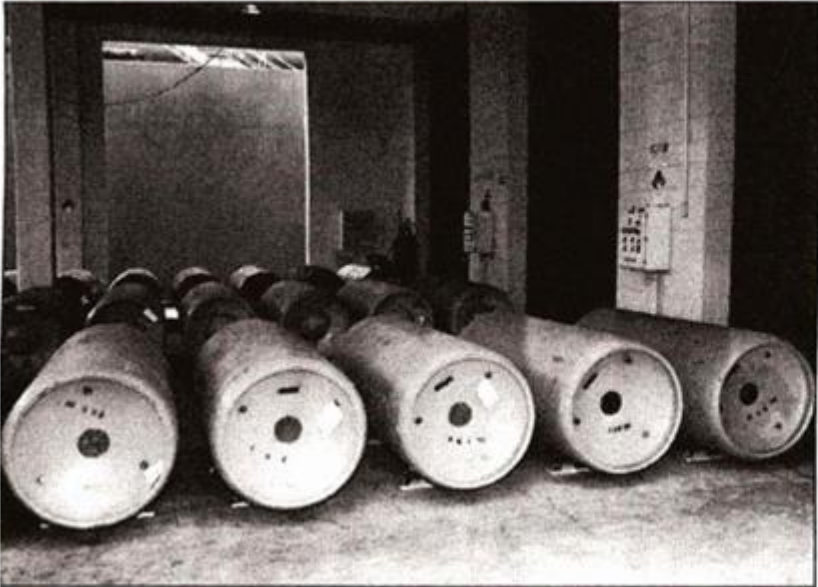

Chlorine application (Gas)

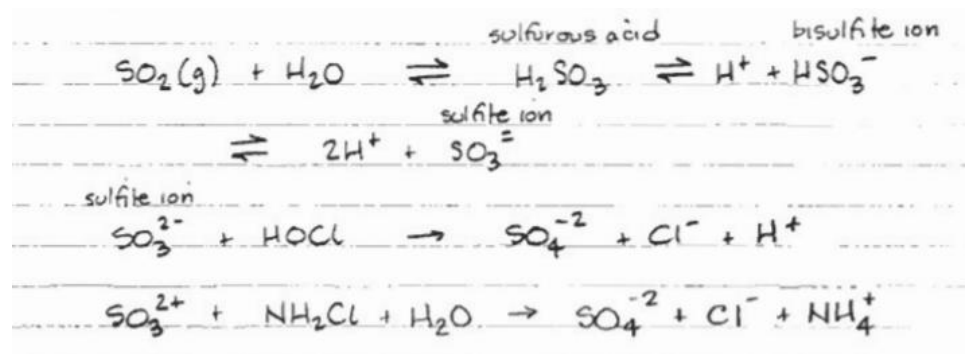
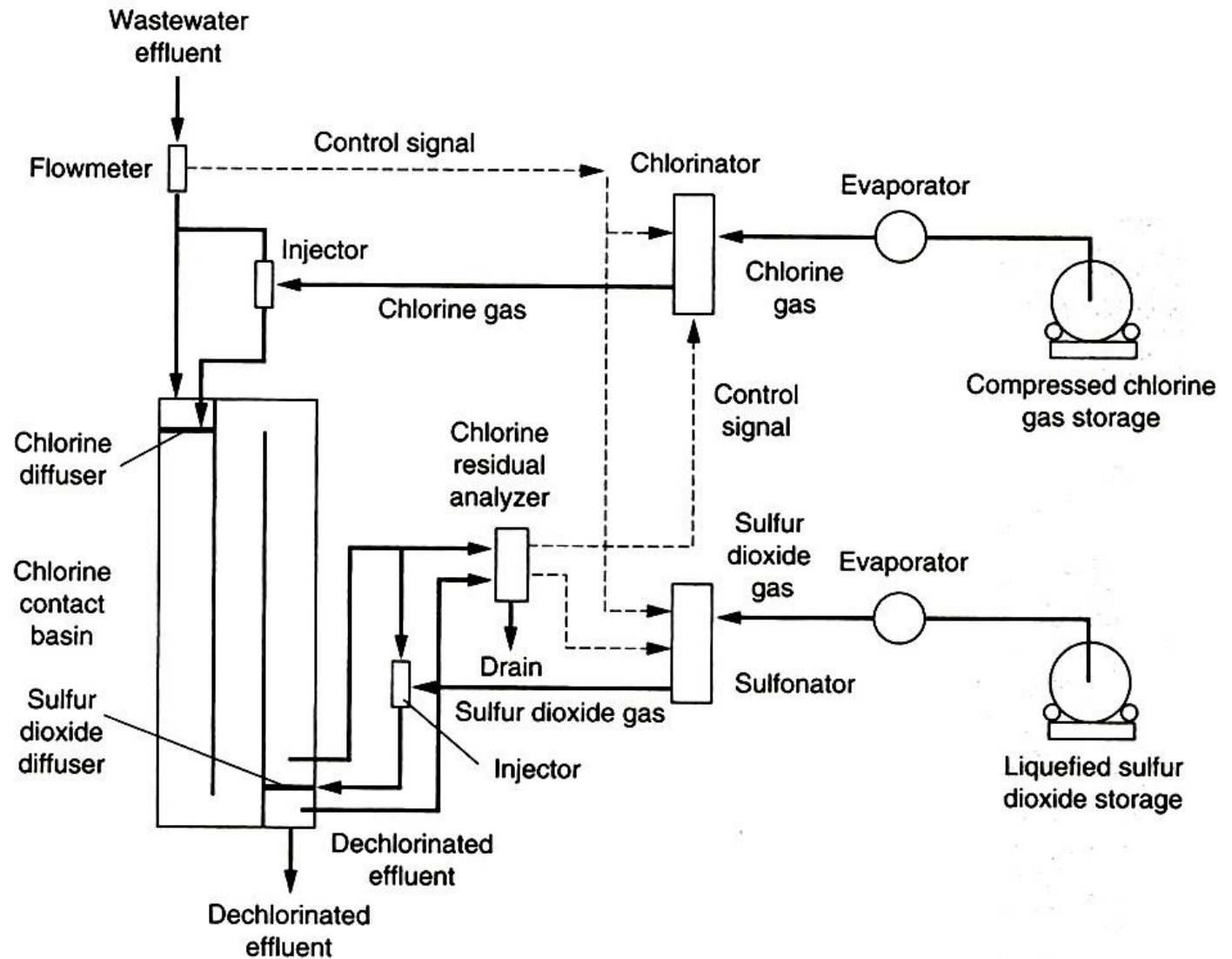

(a)

Chlorine (advantages and disadvantages)

- Advantages
 - Effective against all types of microbes.
 - Relatively simple maintenance and operation.
 - Inexpensive.
- Disadvantages
 - Corrosive.
 - High toxicity.
 - High chemical hazard.
 - Highly sensitive to inorganic and organic loads.
 - Formation of harmful disinfection by-products (DBP's).

Chloramines - History and Background

- First used in 1917 in Ottawa, Canada and in Denver, USA
- became popular in 1930's to control taste and odor problems and bacterial re-growth in distribution system
- decreased usage due to ammonia shortage during World War II
- increased interest due to the discovery of chlorination disinfection by-products during the 1970's
 - alternative primary disinfectant to free chlorine due to low DBP potential
 - secondary disinfectant to ozone and chlorine dioxide disinfection to provide long-lasting residuals

Chloramines - Chemistry

- Two different methods of application (generation)
 - pre-formed chloramines (monochloramine)
 - mix hypochlorite and ammonium chloride (NH_4Cl) solution at Cl_2 : N ratio at 4:1 by weight, 10:1 on a molar ratio at pH 7-9
 - dynamic chloramination
 - initial free chlorine addition, followed by ammonia addition
- Chloramine formation
 - $\text{HOCl} + \text{NH}_3 \rightleftharpoons \text{NH}_2\text{Cl} + \text{H}_2\text{O}$
 - $\text{NH}_2\text{Cl} + 2\text{HOCl} \rightleftharpoons \text{NHCl}_2 + 2\text{H}_2\text{O}$
 - $\text{NHCl}_2 + 3\text{HOCl} \rightleftharpoons \text{NCl}_3 + 3\text{H}_2\text{O}$

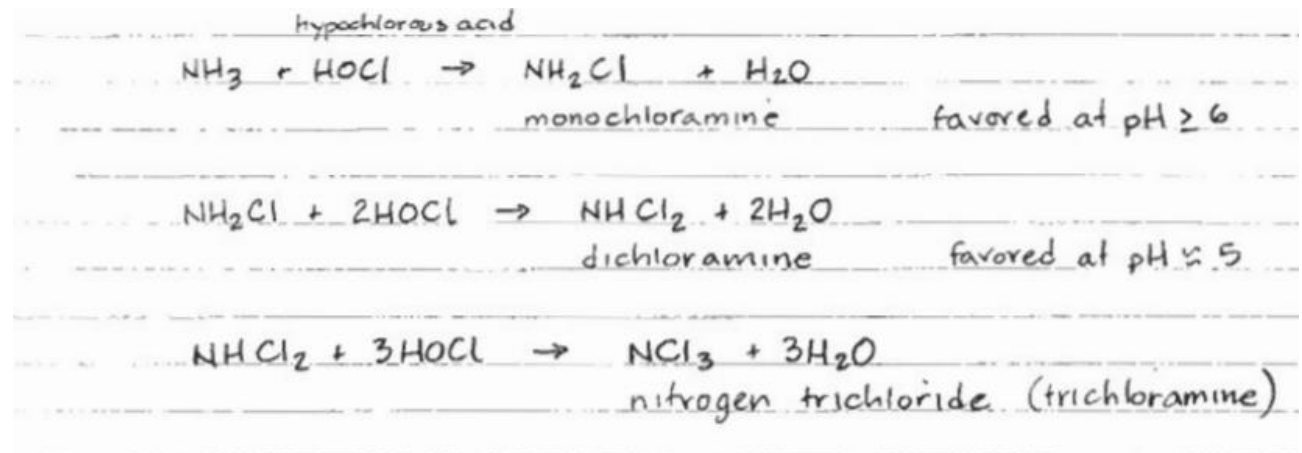

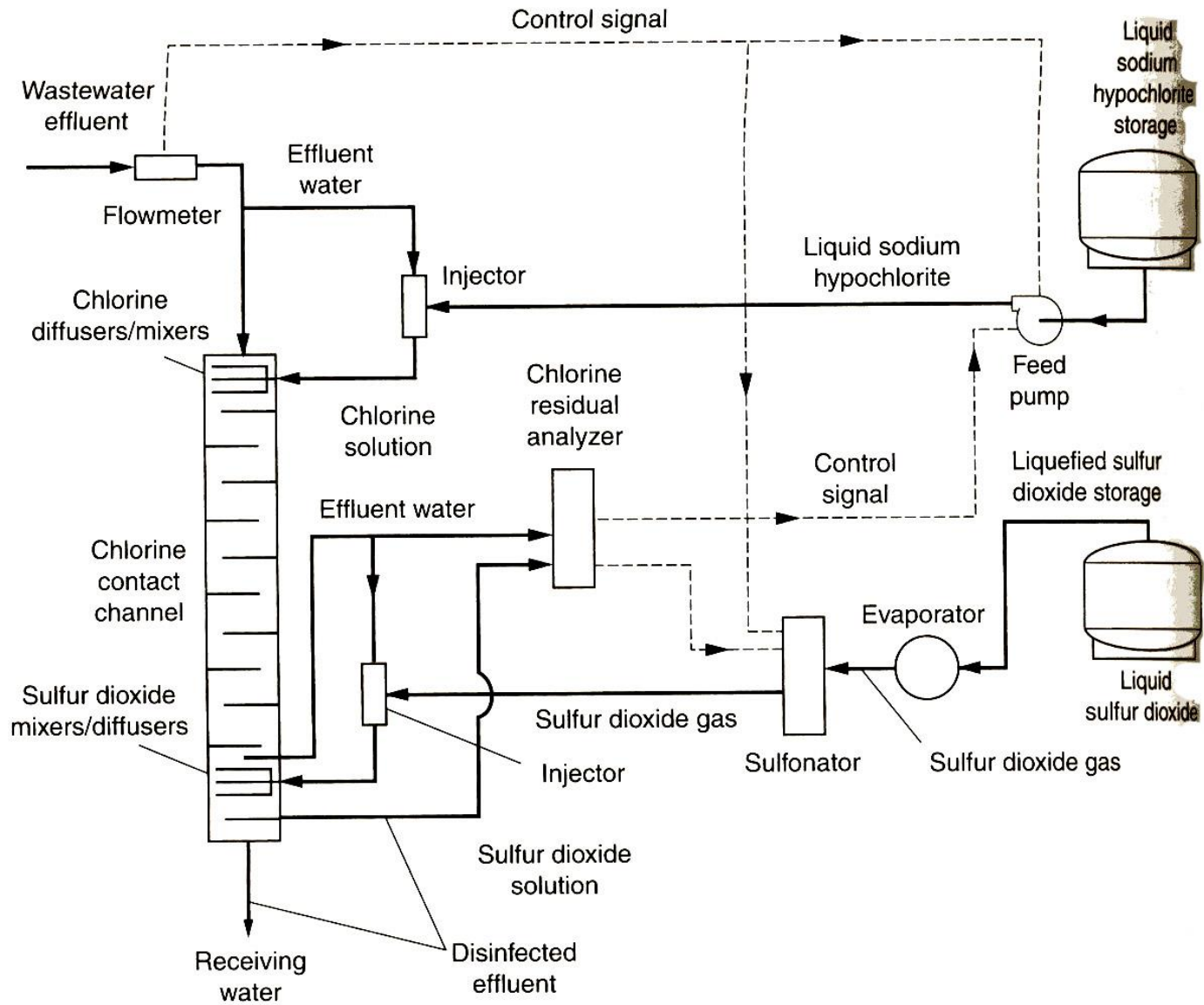

Application of chloramines

Chloramines (advantages and disadvantages)

- Advantages
 - Less corrosive.
 - Less toxicity and chemical hazards.
 - Relatively tolerable to inorganic and organic loads.
 - No known formation of DBP.
 - Relatively long-lasting residuals.
- Disadvantages
 - Not so effective against viruses, protozoan cysts, and bacterial spores

Ozone - History and Background

first used in 1893 at Oudshoorn, Netherlands and at Jerome Park Reservoir in NY (in USA) in 1906

used in more than 1000 WTPs in European countries, but was not so popular in USA

increased interest due to the discovery of chlorination disinfection by-products during the 1970's

- an alternative primary disinfectant to free chlorine
- strong oxidant, strong microbiocidal activity, perhaps less toxic DBPs

Ozone - Chemistry

- The method of application
 - generated by passing dry air (or oxygen) through high voltage electrodes (Ozone generator)
 - bubbled into the water to be treated.
- Ozone
 - colorless gas.
 - relatively unstable.
 - highly reactive.
 - reacts with itself and with OH^- in water

Application of ozone

Figure 12-30

Typical flow diagram for the application of ozone for disinfection.

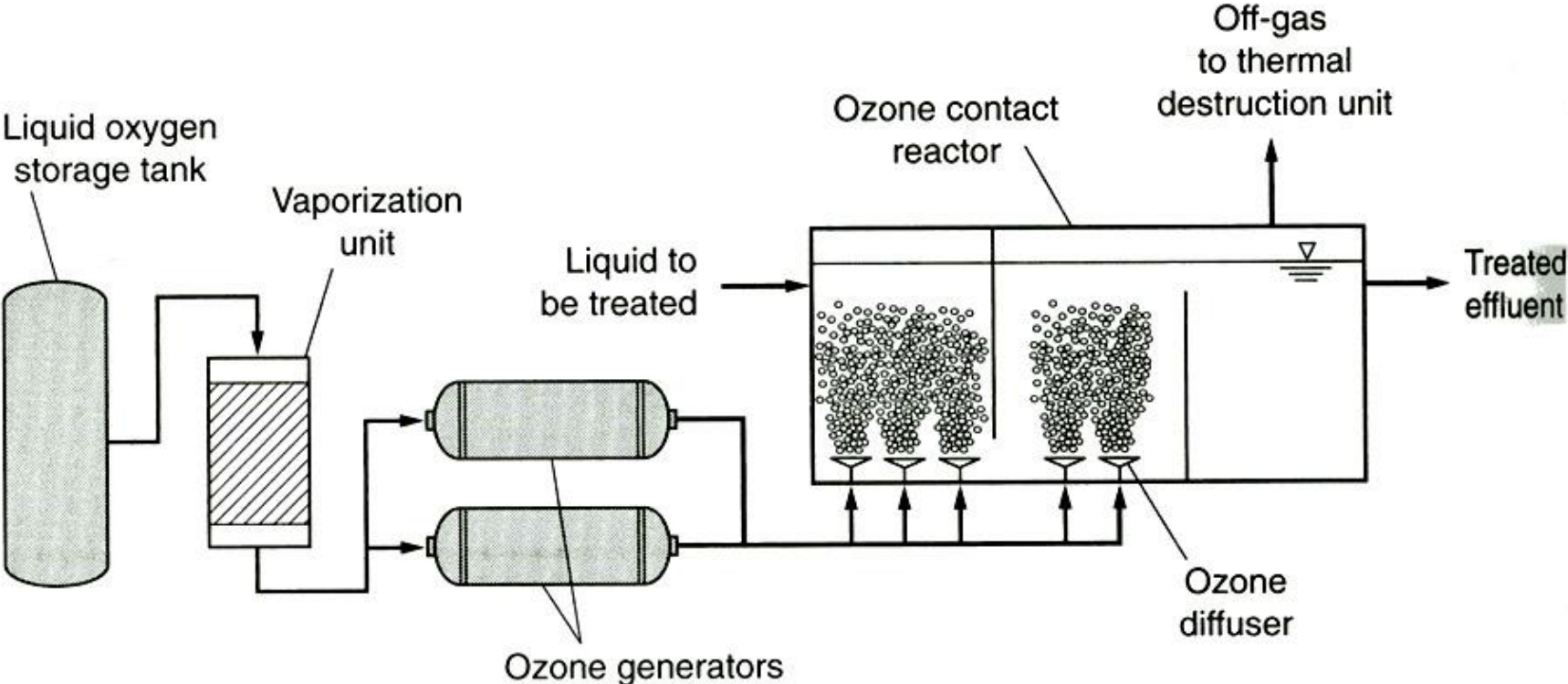

Ozone (advantages and disadvantages)

- Advantages
 - Highly effective against all type of microbes.
- Disadvantages
 - Expensive.
 - Unstable (must produced on-site).
 - High toxicity.
 - High chemical hazards.
 - Highly sensitive to inorganic and organic loads.
 - Formation of harmful disinfection by-products (DBP's).
 - Highly complicated maintenance and operation.
 - No lasting residuals.

Disinfection Kinetics

Assumes:

- all organisms are identical
- death (inactivation) results from a first-order or “single-hit” or exponential reaction.

Chick's law:

$$- \frac{dN}{dT} = kN$$

where: N = number of organisms

T = time

$$\ln \frac{N_t}{N_0} = -kT$$

Where, N_0 = initial number of organisms

N_t = number of organisms remaining at time = T

N_0 = initial number of organisms (T= 0)

Also:

$$\frac{N_t}{N_0} = e^{-kT}$$



Harriette Chick - microbiologist

CT Concept

- Based on Chick-Watson Law
 - Disinfectant concentration and contact time have the same “weight” or contribution in the rate of inactivation and in contributing to CT.
- “Disinfection activity can be expressed as the product of disinfection concentration (C) and contact time (T)”.
- The same CT values will achieve the same amount of inactivation.

Microbial inactivation by chlorine: some *Ct* values reported in the literature

Microorganism	Chlorine Concentration, mg/L	Inactivation Time, min	<i>Ct</i>
<i>Escherichia coli</i> ^a	0.1	0.4	0.04
Adenovirus type 2 ^b			0.023–0.027
Adenovirus type 3 ^b			0.027–0.067
Poliovirus 1 ^a	1.0	1.7	1.7
Human rotaviruses ^c			5.55–5.59
<i>Entamoeba histolytica</i> cysts ^a	5.0	18	90
<i>Giardia lamblia</i> cysts ^a	1.0	50	50
	2.0	40	80
	2.5	100	250
	2.5	100	250
<i>G. muris</i> cysts ^a	2.5	100	250
<i>Cryptosporidium parvum</i> ^c			3700
<i>Cladosporium tenuissimum</i> ^d			71
<i>Aspergillus terreus</i> ^d			1404

^aConditions: 5°C; pH = 6.0 (Hoff and Akin (1986); *Environ. Health Perspect.* 69:7–13).

^bConditions: 4°C; pH = 7 (Page et al. (2009). *Water Res.* 43:2916–2926).

^cConditions: 20°C; pH = 6 (Driedger et al. (2000). *Water Res.* 34:3591–3597).

^dConditions: 25°C; pH = 7 (Pereira et al. (2013). *Water Res.* 47:517–523).

^eConditions: 20°C; pH = 7.2 (Xue et al. (2013a). *Water Res.* 47:3329–3338).

Example

An experiment shows that a concentration of 0.1 g/m^3 of free available chlorine yield a 99% kill of bacteria in 8 minutes. What contact time is required to achieve a 99.9% kill at a free available chlorine concentration of 0.05 g/m^3

Given: For 99% kill: $C = 0.1 \text{ g/m}^3$ and time (t) = 8 minutes

Chick's Law: $N_t = N_0 \times \exp(-k \times t)$

Calculation of disinfection rate constant:

$N_t/N_0 = (1 - 99/100) = 0.01$ in 8 minutes

From Chick's Law: $0.01 = \exp(-k \times 8) \Rightarrow k = - (1/8) \ln(0.01) = 0.5756/\text{min}$ (answer)

Using calculated k value, calculate time for getting 99.9% kill:

$N_t/N_0 = (1 - 99.9/100) = 0.001$

Using Chick's Law: $0.001 = \exp(-0.5756 \times t) \Rightarrow t = - (1/0.5756) \ln(0.001) = 12 \text{ min}$ (answer)

Note: Watson's Law: $C^n \times t = \text{constant} \Rightarrow C \times t = \text{constant}$ (as $n=1$)

For 99.9% kill: $C = 0.1 \text{ g/m}^3$ and time (t) = 8 minutes. So, $C \times t$ value = $(0.1 * 1000 \text{ mg}/1000 \text{ L}) * (12 \text{ minutes})$
= 1.2 (mg/L)(min.)

To determine contact time using 0.05 g/m^3 , Ct is equal for both cases.

$1.2 \text{ (mg/L)(min.)} = (0.05 * 1000 \text{ mg}/1000 \text{ L}) * (t \text{ minutes})$

t = 24 min. (answer)

Example

Given

$$C = 0.1 \text{ g/m}^3, t = 8 \text{ min} \text{ yield}$$

$$99\% \text{ Kill} \Rightarrow \frac{N_t}{N_0} = 1\% = 0.01$$

Req'd :

time to kill 99.9%. Using 0.05 g/m^3

Solution

Since the amount of inactivation (99% and 99.9%) are not the same we can't use $C_1 T_1 = C_2 T_2$ (only when % are equal)

1. Let's find time to kill 99.9% using $0.1 \frac{\text{g}}{\text{m}^3}$

$$2. \underbrace{C_1 T_1}_{\text{at } 0.1 \text{ g/m}^3} = \underbrace{C_2 T_2}_{\text{at } 0.05 \text{ g/m}^3} \text{ ----- (*)}$$

$$\underbrace{\text{Both at } 99.9\%}_{\Rightarrow \frac{N_t}{N_0} = 0.001}$$

* at $C = 0.1 \text{ g/m}^3, \% = 0.1\%$

$$\frac{N_t}{N_0} = e^{-kt} \rightarrow \text{unknown ----- (1)}$$

0.1%

To find k (constant regardless %) apply given data for 99%.

$$\frac{N_t}{N_0} = e^{-kt}$$
$$0.01 = e^{-k(8)} \Rightarrow k = 0.5756 \text{ /min}$$

Apply in (1)

$$\frac{N_t}{N_0} = e^{-kt}$$
$$0.001 = e^{-0.5756(t)} \Rightarrow t = 12 \text{ min}$$

Now apply in (*)

$$C_1 T_1 = C_2 T_2$$
$$0.1(12) = 0.05(T_2) \Rightarrow T_2 = 24 \text{ min} \checkmark$$